

Encoder Cable. EC-...P-QD



- Encoder cable for incremental linear or angular encoders with 1 Vpp or TTL differential signal output.
- Direct connection to Fagor QUERCUS systems.
- Twisted pairs for differential signals.
- Available in 1, 2, 3, 4, 5, 6, 7, 8, 9, 10 & 12 meter lengths for armoured models and 1, 2, 3, 4, 5, 6, 9 & 12 meter lengths for unarmoured models.
- Available with or without armour. Armoured models with 0.75 m free to ease the connection of the shield to the grounding plate.

Pin Out

Pin Input	Colour	Signal	Pin Output
	Green	A	1
	Yellow	/A	2
	Blue	B	3
	Red	/B	4
	Grey	Io	5
	Pink	/Io	6
	Brown	+5 V	9
	White	0 V	11
	Shield	Ground	Housing

Pin Layout

Cable Diagram

Pin Layout



Front view

L = 1, 2, 3, 4, 5, 6, 7, 8, 9, 10, 12 meters armoured
L = 1, 2, 3, 4, 5, 6, 9, 12 meters unarmoured

Note. The armour ends at 0.75 m from the terminating connector. This simplifies the connection of the shield to the grounding plate.

Lead-in Connector

Cable Specification

Terminating Connector

Construction	4 x 2 x 0.14 mm ²
Material	Polyurethane
Ø without armour	6 mm
Bend radius dynamic	≥ 60 mm
Bend radius static	≥ 24 mm
Ø with armour	10 mm
Bend radius dynamic	≥ 60 mm
Bend radius static	≥ 35 mm
Shield	Single
Terminating connector	D-Sub HD 15 pole male

Housing dimensions slightly differ for manufacturers

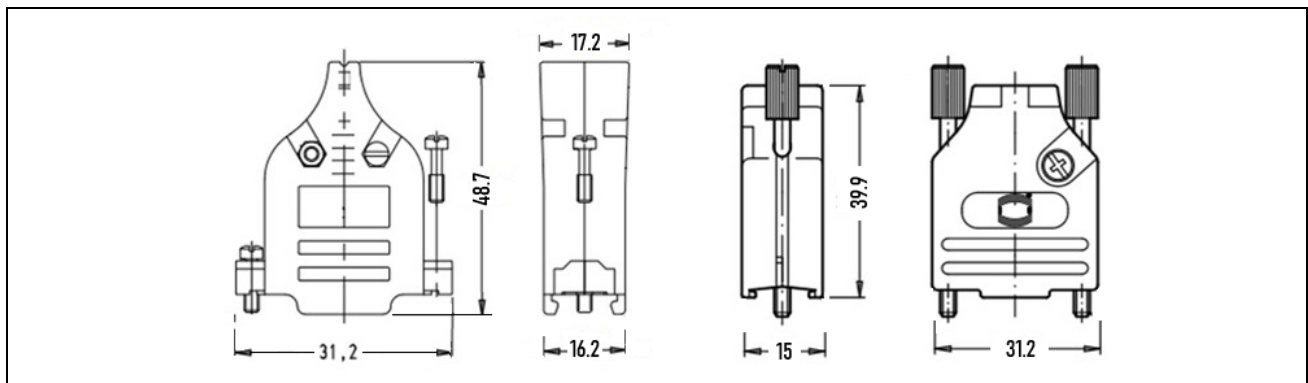

Order Information

EC-(x)P-QD Where (x) = 1, 2, 3, 4, 5, 6, 7, 8, 9, 10 or 12 meters with armour; (x) = 1, 2, 3, 4, 5, 6, 9 or 12 meters without armour, indicate "-N" for no armour.

Example

Order Code	Description
EC-3P-QD	Encoder cable of 3 meters, cable type "P" specifications as above and terminating connector D-Sub HD 15 pole male, with armour.
EC-1P-QD-N	Encoder cable of 1 meter, cable type "P" specifications as above and terminating connector D-Sub HD 15 pole male, without armour.