

**DRIVE**

**DDS**

Hardware manual

Ref.1310



FAGOR AUTOMATION

**All rights reserved.** No part of this documentation may be copied, transmitted, transcribed, stored in a backup device or translated into another language without Fagor Automation's permission.



---

## **Responsibility exemption**

The information described in this manual may be subject to changes due to technical modifications. Fagor Automation S. Coop. reserves the right to change the contents of this manual without prior notice.

The content of this manual and its validity for the product described here has been verified. Nevertheless, the information, technical or otherwise, in these manuals or in any other type of documentation is not guaranteed to be integral, sufficient or up to date.

Involuntary errors are possible, hence the absolute match is guaranteed. However, the contents of manuals and documents are regularly checked and updated implementing the pertinent corrections in later editions.

Fagor Automation S. Coop. will not be held responsible for any losses or damage, direct, indirect or by chance that could result from that information and it will be the user's responsibility to use it.

Responsibility and warranty claims are excluded in case of shipping damage, wrong usage of the unit in wrong environments or when not used for the purpose for which it has been designed, ignoring the warnings and safety indications given in this document and/or legal ones that may be applied to the work place, software modifications and/or repairs made by unauthorized personnel, damage caused by the influence of other nearby equipment.

## **Warranty**

The warranty terms may be requested from your Fagor Automation representative or through the usual commercial channels.

## **Registered trademarks**

All registered trade marks, even those not indicated are also acknowledged. When some are not indicated, it does not mean that they are free.

# GENERAL INDEX

<b>1</b>	<b>DESCRIPTION .....</b>	<b>25</b>
	Description .....	26
	General diagram .....	27
	Stages of the system configuration.....	28
	Environmental and operating conditions.....	29
	Electrical conditions .....	29
<b>2</b>	<b>POWER SUPPLIES .....</b>	<b>31</b>
	Non-regenerative power supplies .....	32
	Regenerative power supplies.....	50
	Regenerative regulated power supplies.....	66
<b>3</b>	<b>DRIVE MODULES .....</b>	<b>95</b>
	Modular drives .....	96
	Compact drives .....	145
	Turning a drive on.....	186
<b>4</b>	<b>AUXILIARY MODULES .....</b>	<b>189</b>
	Mains filters.....	190
	Chokes.....	191
	External Ballast resistors .....	193
	Capacitor module.....	199
	Auxiliary power supply .....	200
<b>5</b>	<b>SELECTING CRITERIA .....</b>	<b>205</b>
	Selection of the synchronous motor and its associated drive .....	205
	Asynchronous spindle motor and servo drive selection.....	211
	Drive selection .....	217
	Power supply selection .....	218
	Capacitor module selection guide.....	228
	Ballast resistor selection guide .....	229
<b>6</b>	<b>POWER LINE CONNECTION.....</b>	<b>233</b>
	Mains connection.....	233
	Protection fuses .....	235
	Differential breaker.....	237
	Isolating transformer or autotransformer.....	238
	Mains filter.....	240
	Line inductance.....	241
	Types of mains.....	242
	Mains connection cables.....	246
<b>7</b>	<b>CABLES .....</b>	<b>247</b>
	Mains connection cable. Power supply - mains connection.....	248
	Power cable. Motor-drive connection.....	249
	Motor feedback cables.....	251
	Direct feedback cable .....	253
	Signal cables for control and communications.....	255
	RS232/RS422 BE adapter .....	259
	RS-232 serial line.....	260
	RS-422 serial line.....	264
<b>8</b>	<b>INSTALLATION .....</b>	<b>267</b>
	Location .....	267
	Inductive components.....	276
	System installation.....	277

Connection between modules.....	279
Power supply connections .....	291
Connection of the control and communications signals.....	293
Check the installation.....	311
<b>9 FUNCTIONAL SAFETY .....</b>	<b>313</b>
STO safety function .....	314
Interface .....	315
Examples .....	316
Precautions .....	318
Risk analysis .....	319
Technical data of the safety function .....	320
Response time .....	321
Cabling and grounding.....	322
Commissioning .....	323
Maintenance, repair and analyze hazardous events .....	324
Decommission and disposal .....	325
<b>10 CONNECTION DIAGRAMS.....</b>	<b>327</b>
SPD modular drive with FM7 asynchronous spindle motor .....	327
AXD modular drive with FKM synchronous axis servo motor .....	328
AXD modular drive with FXM synchronous axis servo motor .....	328
SCD compact drive with FM7 asynchronous spindle motor .....	329
ACD compact drive with FKM synchronous axis servo motor .....	330
ACD compact drive with FXM synchronous axis servo motor .....	331
Electrical cabinet. Diagrams .....	332
Diagrams with a PS-65A power supply.....	338
Diagrams with a PS-25B4 power supply.....	340
Diagrams with a XPS power supply.....	342
Diagrams with an RPS-XX power supply.....	344
Compact system diagrams with SERCOS connection .....	346
Compact system diagrams with CAN connection .....	347
Diagrams of a mixed (combined) system with SERCOS connection.....	349
Diagrams of a mixed (combined) system with CAN connection .....	350
Brake connection diagram for synchronous axis servo motors .....	352
On-the-fly start/delta connection switching on FM7 spindles, E03 & HS3 series .....	353
<b>11 DIMENSIONS.....</b>	<b>355</b>
Main modules.....	355
Power supply modules.....	356
Modular drive modules.....	357
Compact drive modules .....	358
Mains filter.....	359
XPS chokes .....	360
RPS chokes .....	361
External Ballast resistors with external thermostat .....	362
External Ballast resistors with internal thermostat .....	363
External Ballast resistors with external thermostat & cooling fan .....	364
<b>12 SALES REFERENCES .....</b>	<b>365</b>
References of synchronous servo motors .....	366
References of asynchronous motors .....	368
References of modular drives .....	369
References of compact drives .....	370
References of positioning drives.....	371
Power supply references .....	372
References of other elements.....	373
Cable references.....	374



DDS  
HARDWARE

Ref.1310

Order example .....	376
Module identification .....	377
<b>13 COMPATIBILITY .....</b>	<b>379</b>
Mains voltage .....	379
Compatibility .....	379
Module replacement .....	380
VECON board .....	380
VECON-2 board .....	380
VECON-3 board .....	381
VECON-4 board .....	381
Boot for VECON-2 .....	381
Boot for VECON-3 .....	381
Boot for VECON-4 .....	381
SERCOS card (16 MBd) .....	381
CAN board .....	382
CAPMOTOR-x boards .....	382
VECON-X boards .....	382
CAPMOTOR-2 board and type of feedback .....	383
Recognizing RPS power supplies .....	383
APS-24 auxiliary power supply with PS, XPS or RPS .....	383
Power supplies compatible with FM9 motors .....	383





**FAGOR** 

**DDS  
HARDWARE**

**Ref.1310**

# DECLARATION OF CONFORMITY

**Manufacturer** Fagor Automation S.Coop.  
B° San Andrés 19; C.P. 20500, Mondragón, Gipuzkoa - Spain.

**We hereby declare,** under our responsibility the conformity of the product:

## FAGOR DDS SERVO DRIVE SYSTEM

consisting of the following modules and accessories:

**APS-24, PS-25B4, PS-65A, XPS-25, XPS-65,  
RPS-80, RPS-75, RPS-45, RPS-20**

**AXD/SPD 1.08, 1.15, 1.25, 1.35, 2.50, 2.75, 2.85, 3.100, 3.150, 3.200, 3.250**

**ER+TH, ER+TH-18/x+FAN, CM 1.60, CHOKE**

**MAINS FILTER 42A, MAINS FILTER 130A, MAINS FILTER 180A**

**FXM, FKM, FM7, FM9**

*Note. Some additional characters may follow the model references indicated above. They all comply with the directives listed here. However, compliance may be verified on the label of the unit itself.*

mentioned on this declaration, meet the requirements on:

## LOW VOLTAGE DIRECTIVE

IEC 60204-1:2005 +A1: Machinery safety. Electrical equipment of the machines.  
2009 Part 1: General requirements.

## ELECTROMAGNETIC COMPATIBILITY

IEC 61800-3: Category C2. Specific standard on electromagnetic compatibility for servo  
2004 drive systems.

IEC 61326-3-1: (In "Safety Related Parts"). Electrical equipment for measurement, control  
2008 and laboratory use - EMC requirements - Part 3-1: Immunity requirements for  
safety-related systems and for equipment intended to perform safety-related  
functions (functional safety) - General industrial applications.

## SAFETY OF MACHINERY

STO (Safe Torque Off) function satisfies the requirements:

IEC 61800-5-1:2007

IEC 61800-5-2:2007 (SIL 2)

IEC 61508-1:1998 (SIL 2)

IEC 61508-2:2000 (SIL 2)

IEC 61508-3:1998 (SIL 2)

IEC 61508-4:1998 (SIL 2)

ISO 13849-1:2006 + Cor 1:2009: Category 3, for Performance Level PL d

EC-Type-Examination: TÜV SÜD, Notified Body 0123

Certificate No.: Z10 12 06 80353 001

In compliance with EC Directives 2006/95/EC on Low Voltage, Directive 2006/42/EC on Machinery and 2004/108/EC on Electromagnetic Compatibility.

Equipment with date in serial number greater than **2012-05** meets this certification. The date appears on the version label stuck on the outside of the drive module.

Equipment included in the EC-Type-Examination: TÜV SÜD:

AXD X.XXX-A1-X-X	AXD X.XXX-SI-X-X	SPD X.XXX-A1-X-X	SPD X.XXX-SI-X-X
AXD X.XXX-S0-X-X	AXD X.XXX-SD-X-X	SPD X.XXX-S0-X-X	

Are excluded from the scope of the EC-Type-Examination: TÜV SÜD equipment with CAN communication and Drives:

AXD X.XXX-C0-X-X	ACD X.XXX-XX-X-X	MMC X.XXX-XX-XX.XX-X-X-X
SPD X.XXX-C0-X-X	SCD X.XXX-XX-X-X	CMC X.XXX-XX-XX.XX-X-X-X

Fagor Automation, S. Coop.

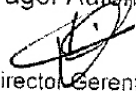
  
Director Gerente  
Pedro Ruiz de Aguirre

In Mondragón, May 2012



Product Service

# CERTIFICATE

No. Z10 12 06 80353 001

**Holder of Certificate:** Fagor Automation, S. Coop.San Andrés Auzoa, 19  
20500 Arrasate - Mondragón  
SPAIN**Factory(ies):** 80353**Certification Mark:****Product:** Safety components  
Safe Torque Off (STO)**Model(s):** Drive module AXD / SPD  
Equipment with date in serial number greater than  
xxxxxxx1205xxxxxx meet this certification  
(see nomenclature)**Parameters:**  
Supply voltage: 24VDC ± 10%  
Current: <50mA  
Operating temperature: +5°C...+45°C**Tested according to:**  
2006/95/EC  
2006/42/EC  
IEC 61800-5-1:2007  
IEC 61800-5-2:2007 (SIL2)  
IEC 61508-1:1998 (SIL 2)  
IEC 61508-2:2000 (SIL 2)  
IEC 61508-3:1998 (SIL 2)  
IEC 61508-4:1998 (SIL 2)  
ISO13849-1/Cor.1:2009 (Cat 3, PL d)  
EN 61326-3-1:2008

The product was tested on a voluntary basis and complies with the essential requirements. The certification mark shown above can be affixed on the product. It is not permitted to alter the certification mark in any way. In addition the certification holder must not transfer the certificate to third parties. See also notes overleaf.

**Test report no.:** 717504886**Valid until:** 2017-07-08**Date,** 2012-07-10 (Peter Weiss)

Page 1 of 3





# Attachment to the certificate Z10 12 06 80353 001

Product Service

Nomenclature of product type

Equipment with date in serial number greater than xxxxxxxx1205xxxxxx meet this certification

MODULAR AXIS DRIVE, AXD

X . XXX - XX - X - X  
(A) (B) (C) (D) (E)

(A) SIZE (width)	<b>1</b>	77 mm < 08, 15, 25, 35 >
	<b>2</b>	117 mm < 50, 75 >
	<b>3</b>	234 mm < 100, 150 >

(B) CURRENT (A) IS1, I <sub>max</sub> for IGBT switching frequencies of 4 / 8 kHz.	<b>08</b>	4.0 / 8.0
	<b>15</b>	7.5 / 15.0
	<b>25</b>	12.5 / 25.0
	<b>35</b>	17.5 / 35.0
	<b>50</b>	23.5 / 47.0
	<b>75</b>	37.5 / 75.0
	<b>100</b>	50.0 / 100.0
<b>150</b>	75.0 / 150.0	

(C) INTERFACE	<b>A1</b>	Analog I/O
	<b>S0</b>	SERCOS
	<b>SI</b>	SERCOS and Analog I/O
	<b>SD</b>	SERCOS, Analog and Digital 8I/16O

(D) ADDITIONAL FEEDBACK FEATURES	<b>0</b>	None
	<b>1</b>	Encoder Simulator
	<b>2</b>	Direct Feedback

(E) MOTOR FEEDBACK BOARD	<b>None</b>	CAPMOTOR-1
	<b>B</b>	CAPMOTOR-2



MODULAR SPINDLE DRIVE, SPD

Product Service

X . XXX - XX - X - X  
 (A) (B) (C) (D) (E)

(A) SIZE (width)	<b>1</b>	77 mm < 15, 25, 35 >
	<b>2</b>	117 mm < 50, 75, 85 >
	<b>3</b>	234 mm < 100, 150, 200, 250 >

(B) CURRENT (A)	for fc = 4 kHz	
IS1 / I <sub>max</sub>	<b>15</b>	10.5 / 13.7
	<b>25</b>	16.0 / 20.8
fc: IGBT's switching frequencies	<b>35</b>	23.1 / 30.0
	<b>50</b>	31.0 / 40.3
	<b>75</b>	42.0 / 54.6
	<b>85</b>	50.0 / 65.0
	<b>100</b>	70.0 / 91.0
	<b>150</b>	90.0 / 117.0
	<b>200</b>	121.0 / 157.3
	<b>250</b>	135.0 / 175.5
	for fc = 8 kHz	
	<b>15</b>	10.5 / 11.6
	<b>25</b>	13.0 / 16.9
	<b>35</b>	18.0 / 23.4
	<b>50</b>	27.0 / 35.1
	<b>75</b>	32.0 / 41.6
	<b>85</b>	37.0 / 48.1
	<b>100</b>	56.0 / 72.8
	<b>150</b>	70.0 / 91.0
	<b>200</b>	97.0 / 126.1
	<b>250</b>	108.0 / 140.4

(C) INTERFACE	<b>A1</b>	Analog I/O
	<b>S0</b>	SERCOS
	<b>SI</b>	SERCOS and Analog I/O

(D) ADDITIONAL FEEDBACK FEATURES	<b>0</b>	None
	<b>1</b>	Encoder Simulator
	<b>2</b>	Direct Feedback

(E) MOTOR FEEDBACK BOARD	<b>None</b>	CAPMOTOR-1
	<b>B</b>	CAPMOTOR-2

Department:

Date: TR-RA/MUC

Page 3 of 3

2012-07-10



## - ABOUT THIS MANUAL -

<b>Title</b>	<b>DRIVE DDS.</b> Hardware manual.
<b>Type of documentation</b>	Description, installation and start-up of digital servo drives.
<b>Electronic document</b>	man_dds_hard.pdf.
<b>Language</b>	English.
<b>Manual reference</b>	Ref.1310.
<b>Web</b>	The user must always use the latest reference of this manual, available on FAGOR'S corporate website. <a href="http://www.fagorautomation.com">http://www.fagorautomation.com</a>
<b>Email</b>	<a href="mailto:info@fagorautomation.es">info@fagorautomation.es</a>
<b>Internal code</b>	It belongs to the manual directed to the manufacturer (OEM). The manual code is: MAN REGUL (IN) STAN Code 04754001 MAN REGUL (IN) AVANZ Code 04754021

### Startup



**DANGER.** In order to comply with the EC seal indicated on the component, verify that the machine on which the servo system is installed complies with European Directive 2006/42/EC on machine safety.

Before starting the servo drive system up, read the instructions in chapter 1 of this manual.

### Warning



**WARNING.** The information described in this manual may be subject to changes due to technical modifications.

FAGOR AUTOMATION, S. Coop. reserves the right to change the contents of this manual without prior notice.

### Headquarters

Fagor Automation, S. Coop.  
B° San Andrés 19, apdo. 144  
CP. 20500 - Arrasate - Mondragón  
Gipuzkoa (Spain)  
[www.fagorautomation.com](http://www.fagorautomation.com)  
[info@fagorautomation.es](mailto:info@fagorautomation.es)

### Customer support



+ 34 943 719200

### Service Department



+ 34 943 771118

**FAGOR** 

**DDS  
HARDWARE**

**Ref.1310**

## - ABOUT THE PRODUCT -

### **Software options**

Bear in mind that some of the features or applications described in this manual depend on the software version installed. These considerations are reflected in the “man\_dds\_soft.pdf” manual supplied with this one.



DDS  
HARDWARE

Ref.1310

## **- SHIPPING CONDITIONS, STORAGE AND RECYCLING -**

### **Shipping**

When shipping the unit, do it protected against blows and pack it in its original cardboard box with its original packing material. If you do not have the original packaging material, pack it as follows:

1. Get a cardboard box whose 3 inside dimensions are at least 15 cm (6 inches) larger than those of the unit. The cardboard used to make the box must have a resistance of 170 kg (375 lb).
2. Attach a label to the unit indicating the owner of the unit, his address and name of the person to contact, type of unit and serial number.
3. In case of failure, also indicate the symptom and a short description of the failure.
4. Protect the unit wrapping it up with a roll of polyethylene or with similar material.
5. Pad the unit inside the cardboard box filling it with polyurethane foam on all sides.
6. Seal the cardboard box with packaging tape or with industrial staples.

### **Storage**

Store the product only under the allowed ambient conditions indicated here. See this data in chapter 1 of this manual. Always protect the product against dust and dirtiness.

### **Recycling**

The product is made of various materials that may be recycled and eliminated separately. Get rid of the product in compliance with local regulations.



**DDS  
HARDWARE**

**Ref.1310**



DDS  
HARDWARE

Ref.1310

## - VERSION HISTORY -

The history of versions shows the list of the hardware elements added in each manual version. To know the features added in each software version and the version of the manual that describes them, see the "man\_dds\_soft.pdf" manual that is supplied with this one.

Manual reference	Events
9702	First version
9707	PS-65, RM-15, CM-60, APS-24, AXD / SPD 3.xx
9802	Compact 8, 25, 50, 75, DDS PROG MODULE
9810	XPS-25, XPS-65.
9904	New fanned motors FXM. New SPM 180M motor. New products (mains voltage 460 V AC). Description and installation of the XPS. New drive AXD / SPD 1.35 EMK filters
0002 (only in CD Rom)	SPMxx.1 Motors PS-25B3 and PS-25B4 ER resistors WinDDSSetup Improved AXD / SPD 1.15. Digital I/O boards
0103	No new hardware has been implemented
0112	FXM motors at 400-15% V AC MMC and CMC drives ACD / SCD 1.08 / 1.15 drive (compact) Crowbar resistor: ER-18/1800 and ER-18/2200 RS-422 interface for MMC and CMC drives
0303	New drive SPD 2.85 New drive SPD 3.200 New capacitor module CM 1.60 (replaces the previous CM 60) New spindle motors FM7 (E01 and E02 versions)
0305	New encoder E3 (similar to E2 but with tapered shaft).
0310	No new hardware has been implemented
0403	From February of 2004 on, compact drive modules ACD 2.50, SCD 2.50, ACD 2.75, SCD 2.75, CMC 2.50, CMC 2.75 and the programming module DDS PROG MODULE will no longer be in Fagor Automation' catalog. However, all the documentation regarding them is kept in this manual just in case the user has already purchased any of these modules.
0405	From this version on, our catalogs show the mains filter model MAINS FILTER 42A and MAINS FILTER 130A.
0407	No new hardware has been implemented.
0410	New SERCOS board (transmission speed up to 16Mbd)



**DDS  
HARDWARE**

**Ref.1310**

Manual reference	Events
0602	New compact drives: ACD/SCD/CMC 1.25A New compact drives: ACD/SCD/CMC 2.35 New resistors: ER-33/550 and ER-18/900 (as accessory) Regenerative regulated power supplies. Boost (step-up) power Supplies: RPS-75, RPS-45 and RPS-20. Choke RPS-75, choke RPS-45 and choke RPS-20.
0606	No new hardware has been implemented.
0612	New choke XPS-65 (smaller and lighter).
0706	New VECON-3 board Sales references of the glass fiber optic cable SF0-V-FLEX New ER-18/1000+FAN resistor with fan.
0710	No new hardware has been implemented.
0802	New compact drives: ACD/SCD/CMC 2.50. There are now 3 switches for selecting the ballast resistor on PS-25B4 power supplies. New CAPMOTOR-2 board.
0806	The choke RPS-75-3 replaces the choke RPS-75. There are now 3 switches for selecting the ballast resistor on PS-65A power supplies.
0811	The following are being replaced: External 18 Ω /1800 W Ballast resistor that is supplied as an accessory in certain units for 18Ω/1800W with internal thermostat. External Ballast resistor ER-18/2200 by ER+TH-18/2200 with internal thermostat.
0905	External 24Ω/750W Ballast resistor that is supplied as an accessory in certain units for 24Ω/750W with external thermostat. Changing the power connector for motor connection at SPD 3.200 drives.
1003	The external ballast resistor with fan ER-18/1000+FAN has been replaced with the new ER+TH-18/1000+FAN with fan and external thermostat. The auxiliary APS 24 power supply has been modified and it can now be connected to the DC bus of the PS, XPS and RPS power supplies. New regenerative regulated power supply RPS-80 New modular spindle drive SPD 3.250
1107	No new hardware has been implemented.
1109	No new hardware has been implemented.
1209	Functional safety. STO safety function. New spindle compact drive SCD 2.75.
1305	New CHOKE XPS-65-A that replaces the CHOKE XPS-65
1307	New VECON-4 board
1310	No new hardware has been implemented.



DDS  
HARDWARE

Ref.1310

# - SAFETY CONDITIONS -

Read the following safety instructions in order to prevent harming people and damage to this product or to the products connected to it.



**MANDATORY.** Always use the latest reference (version) of this manual. It is available on FAGOR's corporate website. <http://www.fagorautomation.com>



**MANDATORY.** Refer to **chapter 9** of this manual for any information on **FUNCTIONAL SAFETY** of the DDS system.

## Qualification of personnel

The unit can only be repaired by personnel authorized by Fagor Automation.

Only specialized technicians that know and understand the contents of this manual and all the documentation related to the units may handle any of these units.

They must be trained on safety so they can identify and prevent any danger. Based on their technical training, knowledge and experience, they must be able to foresee and recognize any possible danger that may be caused by using these units, changing their settings and in general by the mechanical, electrical and electronic devices that make up the whole system.

They must also know the current regulations and standards for preventing accidents that must be borne in mind when handling these units.

Fagor Automation shall not be held responsible of any physical or material damage originated from not complying with these basic safety rules.

## Forseen usage

- ❑ **Destine** the units to an **industrial environment** as instructed in this manual.
- ❑ **Cumply** always with the current **safety standards**, the **indicated conditions** and the **technical data**.
- ❑ **Analyze risks** related to the application before using the unit and **take the proper safety measures** according to the results obtained.
- ❑ **Ensure personnel safety** anywhere in the system that these units belong to.
- ❑ **Never use in explosive environments** (dangerous areas).
- ❑ **The electrical equipment must only be handled** by qualified personnel (installation, operation, maintenance, service).

## Precautions against personal harm

- ❑ **Do not use damaged products.**
- ❑ **Use the right mains cables.**  
In order to avoid risks, use only the SERCOS or CAN and mains cables recommended for this unit. Wrong cabling may cause unexpected movements and cause personal injury.
- ❑ **Avoid electric shocks.**  
To avoid electric shocks and the risk of fire, do not apply electrical voltage beyond the range indicated in this manual.
- ❑ **Make the ground connection.**  
In order to avoid electric shocks, connect the ground terminal of this unit to the main ground point. Also, before connecting the inputs and outputs, make sure that the ground connection has been done.

**FAGOR**

**DDS  
HARDWARE**

**Ref.1310**

❑ **Make sure that the ground connection has been made.**

In order to avoid electric shocks, before turning the unit on, make sure that the ground connection has been made. It is up to the installer to comply with current regulations and standards regarding the ground connection of the servo drive system.

Do not use the conduit as ground protection, use the protection ground wire inside the conduit.

❑ **Only use tools with electrical insulation.**

Many components of the product, including the pc board, work with mains voltage. Don't touch them.

Do not touch unshielded components or pins when under voltage.

❑ **Make sure not to work in humid environments.**

To avoid electric shocks, always work in environments where relative humidity is lower than 90% without condensation at 45 °C (113 °F).

❑ **Make sure not to work in explosive environments.**

In order to avoid risks, harm or damages, do not work in explosive environments.

❑ **The motor generates voltage when turning the shaft. Before working on the servo system, lock the motor shaft to prevent it from turning.**

❑ **Do not short-circuit the terminals of the DC bus nor those of the capacitors of the DC bus.**

❑ **Avoid touching the hot braking resistor.**

❑ **Don't allow flammable or heat sensitive substances near the braking resistor.**

❑ **Foreign conducting elements, dust or liquids can cause the STO safety function to stop working. Do not use the STO safety function unless the system has been protected against pollution by conducting substances.**

❑ **Make sure that any conducting element, no matter how small, cannot get inside the unit (pollution degree 2) because it could render the safety function inoperative**

❑ **Follow thoroughly the measures given by EMC.**

Malfunctions (due to ignoring electromagnetic compatibility) can cause unexpected system behavior. Do the whole wiring carefully according to the measures given by EMC. Do not adjust the unit with unknown data. Start the system up carefully. Ignoring these warning can cause serious injury or even death. Follow thoroughly the measures given by EMC to avoid risks and personal injury.

## **Precautions against damage to the product**

❑ **Work environment.**

This unit is ready to be used in industrial environments and comply with the current directives and regulations of the European Community.

Fagor Automation shall not be held responsible for any damage that could suffer or cause when installed under other conditions (residential or domestic environments).

❑ **Install the unit in the right place.**

We recommend that, whenever possible, the servo drive system be installed away from coolants, chemicals, blows, etc. that could damage it. Keep foreign elements such as chips, screws or wire pieces away from the units. Foreign conducting elements may damage the product or generate parasite voltages.

Provide good heat dissipation.

This unit meets the European directives on electromagnetic compatibility. Nevertheless, it is recommended to keep it away from sources of electromagnetic disturbance, such as:

- Powerful loads connected to the same mains as the unit.
- Portable nearby transmitters (radio-telephones, CB radio emitters).
- Nearby radio/TV transmitters.
- Nearby arc welding machines.
- Nearby high voltage lines ...

❑ **Enclosures.**

It is up to the manufacturer to guarantee that the enclosure where the unit has been installed meets all the relevant directives of the European Union.

❑ **Connecting the power supply to ground.**

The zero Volt point of the external power supply must be connected to the main ground point of the machine. Poor grounding increases the risk of electrical shock.



DDS  
HARDWARE

Ref.1310

## Precautions during repairs

### ❑ Do not access the inside of this unit.

Only personnel authorized by Fagor Automation may access the interior of this unit.

### ❑ Do not handle the connectors while the unit is connected to mains.

Before handling the connectors (mains, moving power, feedback, ...) make sure that the unit is not connected to mains.

## Precautions during maintenance

### ❑ Useful life (mission) of the STO safety function.

The useful life (mission) of the STO safety function is 20 years. After that time, the safety function will no longer be valid. The expiration date must be calculated by adding 20 years to the date shown on the version label of the unit. Write down this value in the maintenance plan of the installation. Do not use the safety function after that date.

## Safety symbols

### ❑ Symbols that may appear in this manual



#### **DANGER or prohibition symbol.**

It warns about an immediate dangerous situation. Ignoring this warning may cause serious, even fatal, consequences.



#### **WARNING or caution symbol.**

It warns about a potentially dangerous situation. Ignoring this warning may cause serious injuries (even fatal) or damages to the unit.



#### **MANDATORY symbol.**

It warns about actions and operations that **MUST BE** carried out. In other words, **THEY ARE NOT PLAIN RECOMMENDATIONS**. Ignoring this warning may mean not complying with some safety regulation.



#### **INFORMATION symbol.**

Notes, warnings, advises and recommendations.

### ❑ Symbols that the product may carry



#### **Ground protection symbol.**

It indicates that point must be under voltage.

## - WARRANTY TERMS -

### Initial warranty

**All products manufactured or marketed by Fagor Automation carry a 12-month warranty for the end user.**

In order to prevent the possibility of having the time period from the time a product leaves our warehouse until the end user actually receives it run against this 12-month warranty, the OEM or distributor must communicate to Fagor Automation the destination, identification and installation date of the machine by filling out the Warranty Form that comes with each product.

**The starting date of the warranty for the user will be the one appearing as the installation date of the machine on the Warranty Form.**

This system ensures the 12-month warranty period for the user.

Fagor offers a 12-month period for the OEM or distributor for selling and installing the product. This means that the warranty starting date may be up to one year after the product has left our warehouse so long as the warranty control sheet has been sent back to us. This translates into the extension of warranty period to two years since the product left Fagor Automation's warehouse. If this sheet has not been sent to us, the warranty period ends 15 months from when the product left our warehouse.

Fagor is committed to repairing and replacing its products from the time when the first such product was launched up to 8 years after such product has disappeared from the product catalog.

It is entirely up to FAGOR AUTOMATION S. Coop. to determine whether a repair is to be considered under warranty.

### Exclusive clauses

The repair will be done in our facilities; therefore, all shipping expenses as well as traveling expenses incurred by technical personnel to repair the unit are NOT under this warranty even when the unit is under warranty.

The warranty will be applied so long as the equipment has been installed according to the instructions, it has not been mistreated or damaged by accident or negligence and has been handled by personnel authorized by Fagor Automation.

If once the service call or repair has been completed, the cause of the failure is not to be blamed on those elements, the customer must cover all generated expenses according to current fees.

No other implicit or explicit warranty is covered and FAGOR AUTOMATION shall not be held responsible, under any circumstances, of the damage which could be originated.

### Service contracts

Service and Maintenance Contracts are available for the customer within the warranty period as well as outside of it.



DDS  
HARDWARE

Ref.1310

## - ADDITIONAL NOTES -

Install the DDS servo drive system away from coolants, chemicals, blows, etc that could damage it.

Before turning the unit on, verify that the ground connections have been made properly. See chapter **8. INSTALLATION** of this manual.

In case of a malfunction or product failure, disconnect it and call the technical service department. Do not access the inside of these units.





DDS  
HARDWARE



Ref.1310

## - RECOMMENDED DOCUMENTATION -





### Available manuals

	Manual available in electronic format, included in the CD-ROM		Manual available on paper
---	---	---	---------------------------





### Product selection guides

Document	Description	Format
<b>man_drive_ord_hand.pdf</b> (only in english)	It describes the products that make up the dds system and allows selecting each element according to the user's needs.	
<b>man_fm7/fm9_ord_hand.pdf</b> (only in english)	It describes the FM7/FM9 asynchronous motors and allows selecting each model according to the user's needs.	
<b>man_fkm_ord_hand.pdf</b> (only in english)	It describes the FKM synchronous motors and allows selecting each model according to the user's needs.	





### Quick references

Document	Description	Format
<b>man_dds_mod_quick_ref.pdf</b> (only in english)	It describes each element that make up the system as well as the most important considerations regarding the installation of motors and modular drives, power supplies and accessories such as cables, connectors, etc.	 
<b>man_dds_comp_quick_ref.pdf</b> (only in english)	It describes each element that make up the system as well as the most important considerations regarding the installation of motors and compact drives and accessories such as cables, connectors, etc.	 

### Servo drive system manuals

Document	Description	Format
<b>man_dds_hard.pdf</b> Spanish and <a href="#">english</a>	It describes each device and equipment that make up the servo drive system as well as their installation.	 
<b>man_dds_soft.pdf</b> Spanish and english	It describes the adjustments of the servo drive system. Available parameters, variables and commands. Features. Operation of the WinDDSSetup software for PC.	 

### Electric motor manuals

Document	Description	Format
<b>man_fm7_fm9_motors.pdf</b> Spanish and english	They describe the FM7/FM9 series of asynchronous motors of the FAGOR catalog and how to install them with the DDS system.	 
<b>man_fxm_fkm_motors.pdf</b> Spanish and english	They describe each series of synchronous motors of the FAGOR catalog and how to install them with the DDS system.	 



DDS  
HARDWARE

Ref.1310

# DESCRIPTION



The DDS servo drive system is ready to be used in industrial environments. It may be used with the CNC to control the movements and devices of the machine. The configuration of the main DDS servo drive system follows this general diagram:

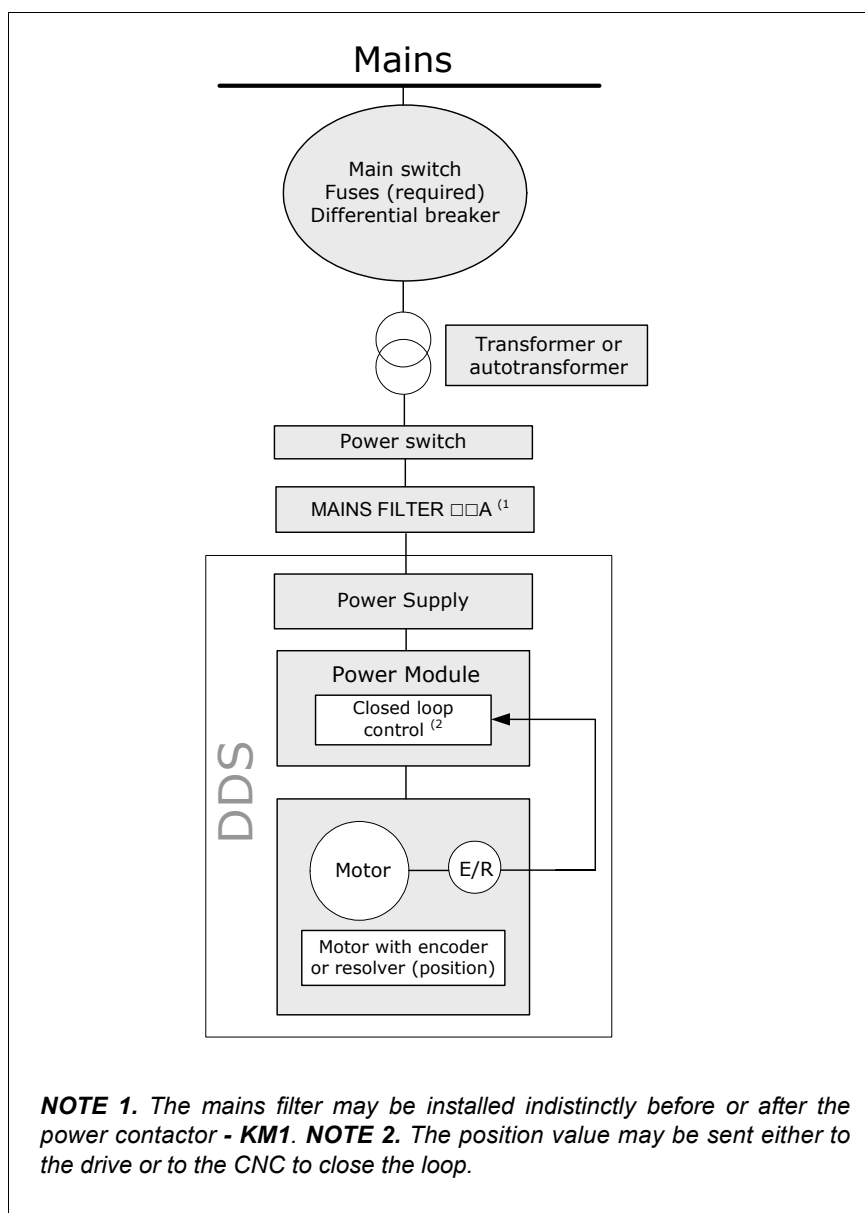

## F. H1/1

DDS servo drive system description.

Each element that make up the previous diagram will be explained in detail in the following chapters.



DDS  
HARDWARE

Ref.1310

## 1.1 Description

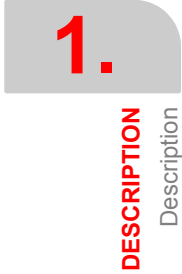

Fagor Automation's Servo Drive System has a modular stackable design.

It may be connected directly to a TN type three-phase mains with a frequency of 50/60 Hz and with a rated voltage between 400-10% and 460+10% V AC.

This system supplies the electric motors with a three-phase voltage of 400-4.5% V AC and a variable frequency with which it will govern its speed.

Certain mandatory protection devices must be added between the mains lines and the DDS servo drive system. Others may be optional. These elements are:

Main switch	Mandatory
Fuses	Mandatory
Differential breaker	Optional
Transformer or auto-transformer	Optional
Power switch	Mandatory
Mains filter: MAINS FILTER □□A	Mandatory

According to the user's needs, the DDS system may consist of the following modules:

Non-regenerative power supplies	PS
Regenerative power supplies	XPS
Regenerative regulated power supplies (boost power supplies)	RPS
<b>Modular drives</b>	
Axis velocity and position control	AXD
Spindle velocity and position control	SPD
Axis velocity and position control. It is capable of generating a path on its own.	MMC
<b>Compact drives</b>	
Axis velocity and position control	ACD
Spindle velocity and position control	SCD
Axis velocity and position control. It is capable of generating a path on its own.	CMC
Auxiliary power supply module	APS-24
Capacitor module	CM 1.60
Choke	Choke XPS-□□-□ Choke RPS-75-3 Choke RPS-□□
Resistor module	ER+TH-x/x, ER+TH-18/x+FAN

**INFORMATION.** The DDS system has been manufactured in accordance with EN 60204-1 in compliance with European Directive 2006/95/EC on Low Voltage.



DDS  
HARDWARE

Ref.1310

## 1.2 General diagram

See the schematic description of all the elements that make up the DDS servo drive system:

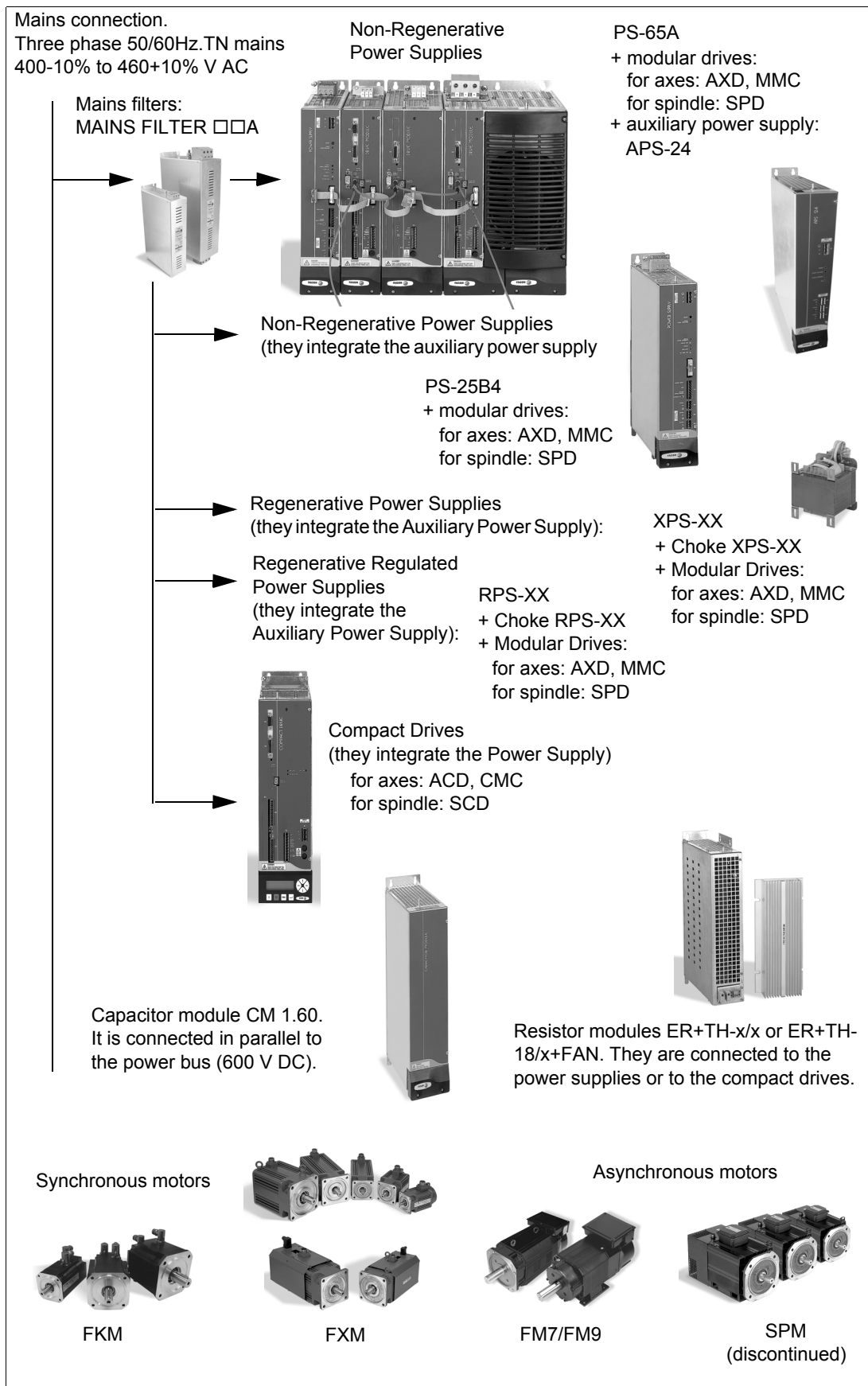

**1.**  
**DESCRIPTION**  
General diagram



**DDS  
HARDWARE**

**Ref.1310**

**F. H1/2**

DDS servo drive system configurations.

## 1.3 Stages of the system configuration

The following steps are a reference to configure and install the DDS system.

**NOTE.** This DDS system configuration process assumes that the motors of the system are known motors.

All the motors of the FAGOR catalog are described in their corresponding manuals:

- Manual of synchronous servo motors. FXM, FKM families
- Asynchronous motor manuals. FM7, FM9 families

1.

**DESCRIPTION**  
Stages of the system configuration

### Example procedure

Stage 1. Analysis of the system location

- Ambient conditions
- Climate conditions
- Cooling conditions
- Mechanical conditions

Stage 2. Component selection

- Motors
- Power supply module
- Drive modules
- Auxiliary modules

Stage 3. Connection configuration

- See block diagrams
- See connection diagrams
- See dimension drawings
- Power and signal cable selection
- Suggestions for cable installation
- Power line connection
- Electrical cabinet and its ventilation



DDS  
HARDWARE

Ref.1310

## 1.4 Environmental and operating conditions

Conditions		Standard	Test reference
<b>Mechanical specifications</b>			
<b>Transport</b>	Vibration	Acc. to IEC 60721-3-2	Class 2M1, vibration sinusoidal 2 Hz < f ≤ 9 Hz, 3.5 mm amplitude 9 Hz < f ≤ 200 Hz, 1 g 200 Hz < f ≤ 500 Hz, 1.5 g
	Shock limits	Acc. to IEC 60721-3-2 IEC 61800-2	Class 2M1, equipment in its transport package
<b>Operation</b>	Environmental testing-vibration (sinusoidal)	Acc. to IEC 60068-2-6 Test Fc	Vibration sinusoidal 10 Hz < f ≤ 57 Hz, 0.075 mm constant amplitude 57 Hz < f ≤ 150 Hz, 1 g constant acceleration
	Degrees of protection provided by enclosure (IP code)	Acc. to EN 60529	IP 2x. It should be installed inside of an electrical cabinet.
<b>Ambient conditions</b>			
<b>Storage *</b>	Ambient temperature	Acc. to IEC 60721-3-1 IEC 61800-2	1K4, - 25 °C to + 60 °C
<b>Transport *</b>	Damp heat test (steady state)	Acc. to IEC 60068-2-78 IEC 61800-5-1	Power Supply disconnected 40 °C +/-2 °C and 93 % +2-3 % non-condensing
	Ambient temperature	Acc. to IEC 61800-2	Equipment introduced in its shipping package - 25 °C to + 70 °C
<b>Operation</b>	Environmental testing-cold	Acc. to IEC 60068-2-1,+	0 °C at operating conditions
	Environmental testing-dry heat	Acc. to IEC 60068-2-2 Test Bd	Operating at rated conditions 45 °C. Operating conditions between 0 °C and 60 °C with derating (see derating characteristics)
	Damp heat test (steady state)	Acc. to IEC 60068-2-78 IEC61800-5-1	Power supply disconnected 40 °C +/-2 °C and 93 % +2-3 % non-condensing
	Installation altitude above mean sea level without derating	Acc. to IEC 61800-5-1 IEC 60664-1	Pollution degree 2 and altitude < 1000 m above sea level at rated conditions

\* The environment during transport and storage must be dry and free from dust.

## 1.5 Electrical conditions

Electrical conditions		
Acc. to IEC 61800-5-1	Protection class	Class I (with protective conductor system)
Acc. to IEC 60664-1	Overvoltages of the supply mains	Category III

1.

DESCRIPTION  
Environmental and operating conditions



DDS  
HARDWARE

Ref.1310



The FAGOR power supplies are connected after the filter to mains (see figure **F. H11/1**) with a mains voltage between 400 and 460 V AC at a mains frequency of 50/60 Hz and its functions are:

- Provide a DC voltage output that will supply the drive modules through the power bus.
- manage the energy excess accumulated in the power bus as a result of braking the motors.

Hence, we refer to:

**Non-regenerative power supplies** when they provide a DC voltage output (depending on mains voltage) and its exceeding energy is dissipated as heat in electrical resistors.

**Regenerative power supplies** when they provide a DC voltage (depending on mains voltage) and its exceeding energy is returned to mains, hence reducing the electrical consumption without generating additional heat.

**Regenerative regulated power supplies** (boost power supplies) when they provide a programmable DC voltage (depending on mains voltage) and its exceeding energy is returned to mains with a power factor close to 1, hence reducing the electrical consumption without generating additional heat.

## 2.1 Non-regenerative power supplies

When referring to non-regenerative power supplies, we'll use PS-25B4 and PS-65A. They all admit a voltage range between 400 to 460 V AC. They are:

# 2.

**POWER SUPPLIES**  
Non-regenerative power supplies

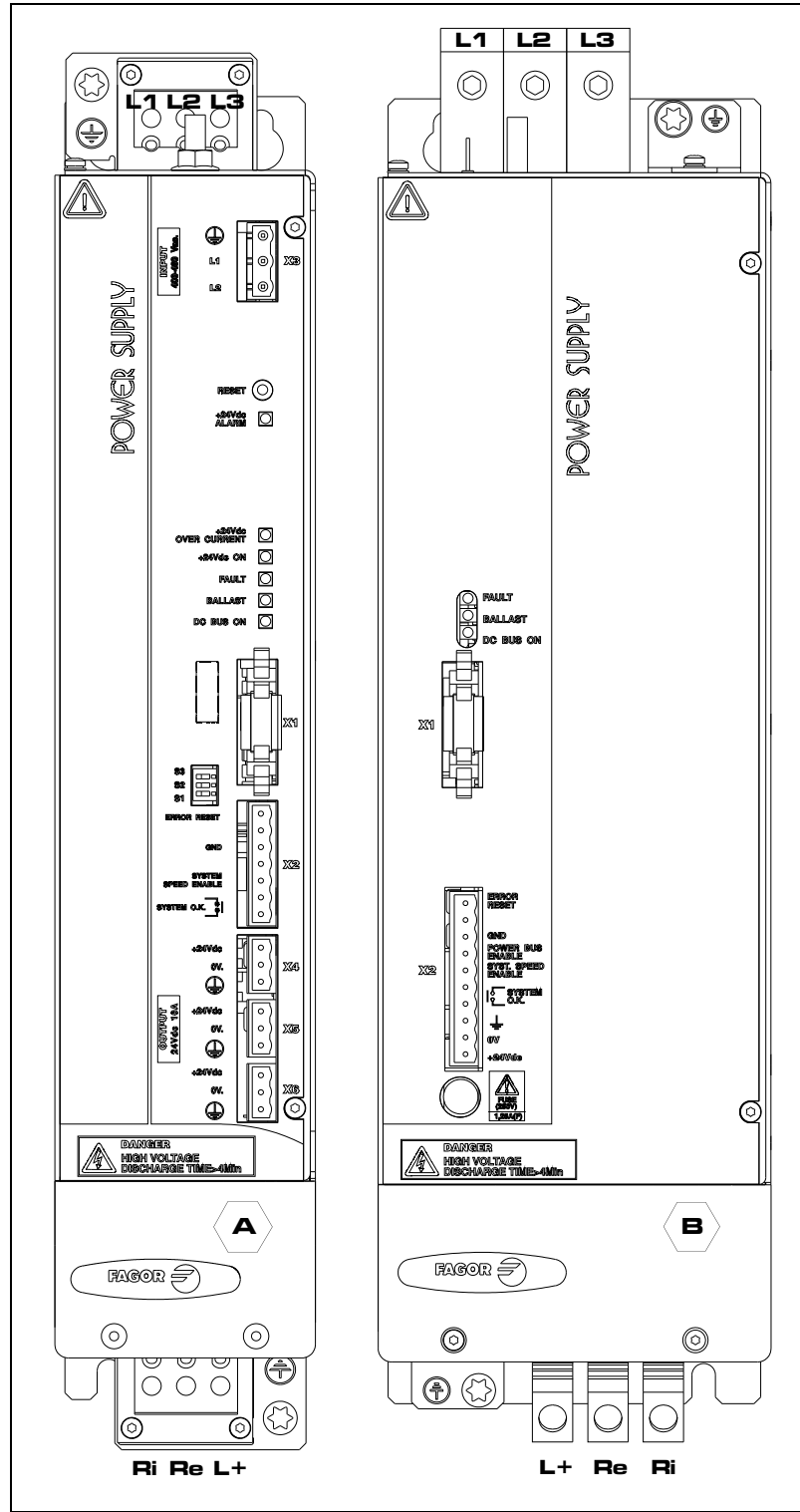

F. H2/1

Non-regenerative power supplies: **A.** PS-25B4, **B.** PS-65A.

The **PS-25B4** supplies 25 kW and includes an internal auxiliary 24 V DC power supply for the control circuits of the modular drives. The over-voltage and ballast alarm activation levels are the ones of the power supplies that admit 460 V AC. The **PS-65A** supplies 65 kW and always needs an auxiliary power supply APS-24 for the control circuits of the modular drives.



DDS  
HARDWARE

Ref.1310

**PS-65A module**

**Technical data**

**T. H2/1** Technical characteristics.

	<b>PS-65A</b>
Power supply (Vmains)	Three-phase 50/60 Hz, with a voltage range between 400-10% and 460+10% V AC
Mains power consumption (400 V AC)	95 Arms
Maximum connection cable section	50 mm <sup>2</sup>
Power bus voltage VbusNom	565 V DC / 650 V DC
Rated (peak) output current <sup>1</sup>	120 A (360 A, 1 s)
Rated (peak) output power	65 kW (195 kW, 1 s)
Power for the module control circuit	24 V DC (between 21 V DC and 28 V DC)
Consumption of the module control circuit itself	1 A at 24 V DC (24 W)
Internal Ballast resistance (power) <sup>1</sup>	9 Ω (600 W)
Energy pulse to be dissipated	36 kW (0.6 s)
Ballast circuit on/off	768 V DC / 760 V DC
Minimum external Ballast resistance	9 Ω
Filter capacity	750 μF, 900 V DC
Energy stored in the capacitors	0.5 C·V <sup>2</sup>
Maximum "SYSTEM OK" contact voltage	125 V AC, 150 V DC
Maximum "SYSTEM OK" contact current	1 A
Width	117 mm (4.61 in)
Approx. mass	9.9 kg (22 lb)
Power dissipated at maximum load	275 W

<sup>1</sup> See derating curves in case of high temperatures.

**T. H2/2** Ambient conditions and other characteristics.

	<b>PS-65A</b>
Ambient temperature <sup>1</sup>	5 °C / 45 °C (41 °F / 113 °F)
Storage temperature	- 20 °C / 60 °C (- 4 °F / 140 °F)
Maximum humidity	< 90% (non condensing at 45 °C / 113 °F)
Maximum altitude without loss of features	1000 m (3281 ft) above sea level
Operating vibration	0.5 G
Shipping vibration	2 G
Sealing	IP 20
Protections	Over-voltage, heat-sink temperature, hardware error, Ballast overload.

<sup>1</sup> See derating curves in case of high temperatures.



**WARNING.** Note that PS-65A power supplies admit a mains voltage of up to 460 V AC.

**2.**

**POWER SUPPLIES**  
Non-regenerative power supplies



**DDS  
HARDWARE**

**Ref.1310**

# 2.

**POWER SUPPLIES**  
Non-regenerative power supplies

## Power diagram

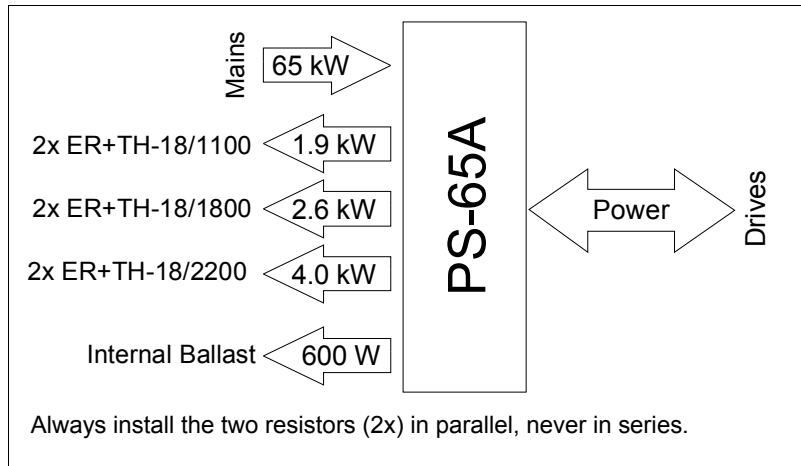

### F. H2/2

Power diagram.

## Block diagram

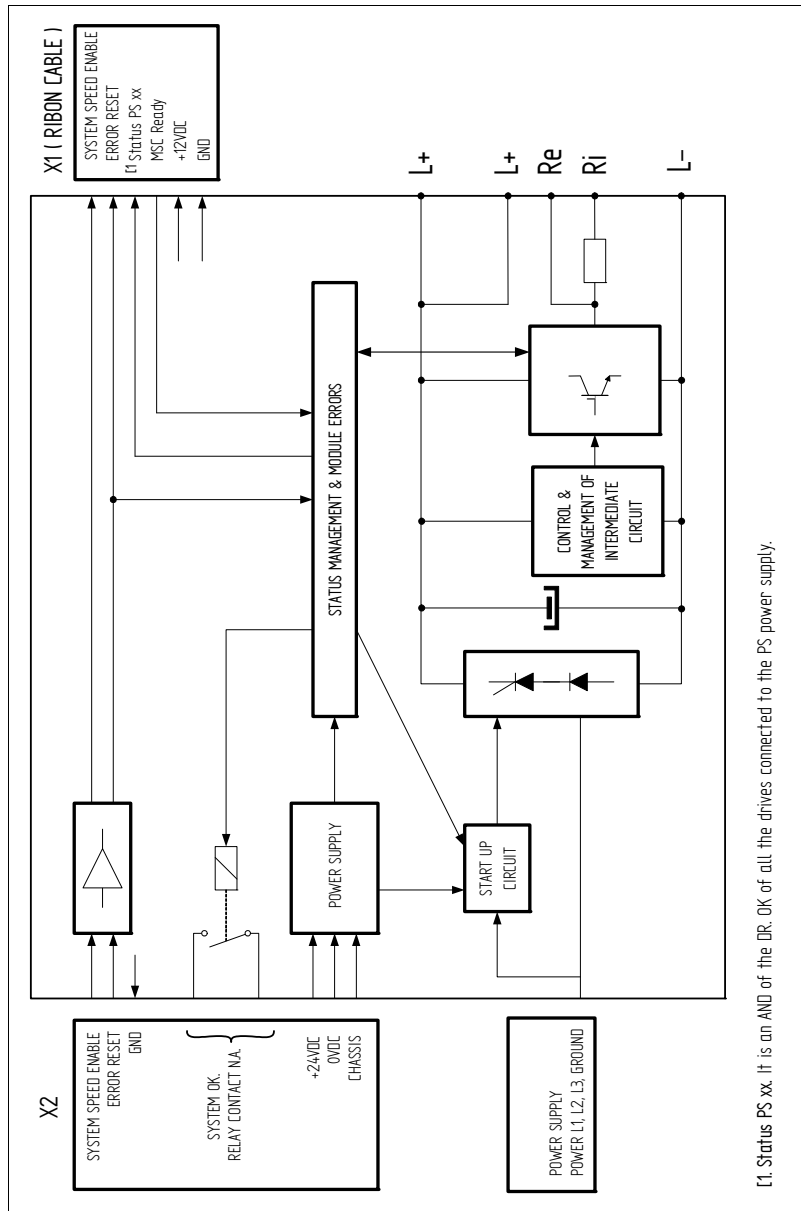

### F. H2/3

Block diagram.



DDS  
HARDWARE

Ref.1310

### PS-65A. Connector description

The non-regenerative power supply PS-65A has the following connectors:

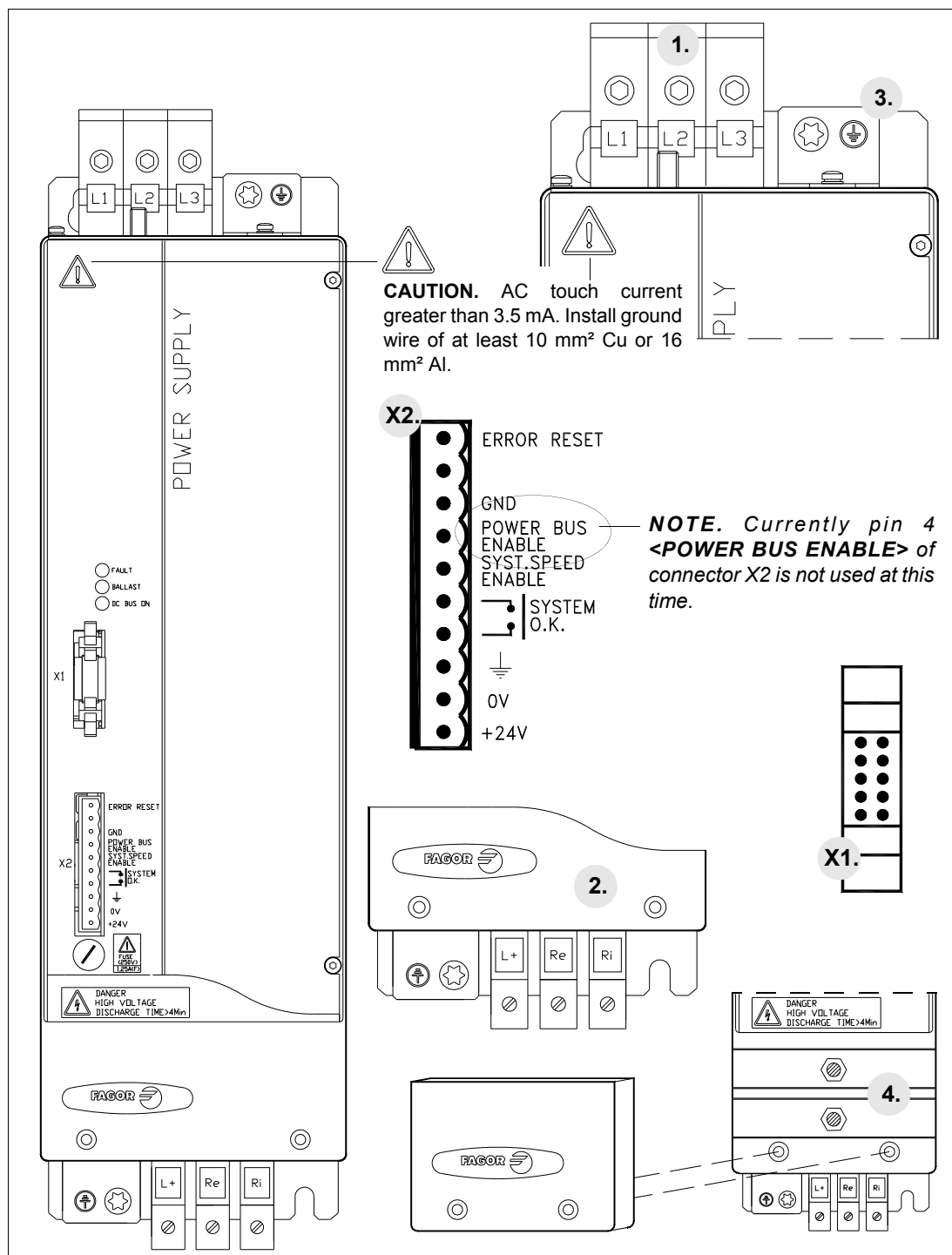

## 2.

**POWER SUPPLIES**  
Non-regenerative power supplies

#### F. H2/4

Connectors of the PS-65A power supply.

1. Power connector for the three-phase mains.
  2. Power connector for the external Ballast resistor connection.
  3. Ground connection for the mains cable.
  4. Power Bus supplying power to the drive modules through metal bars.
- X1. Connector for inter-module communication.  
X2. Connector for the basic control signals.



**DDS  
HARDWARE**

Ref.1310

# 2.

POWER SUPPLIES  
Non-regenerative power supplies

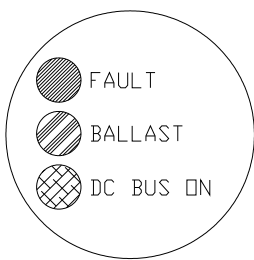

### Status indicator lamps

The non-regenerative power supply PS-65A has the following lights on the front panel to indicate the status of the main power supply.

- **FAULT blinking.** The blinking red led indicates that **there are no errors** and that **one or several mains phases are missing**.
- **FAULT turned ON.** The steady red led on indicates that there is an error. The error is indicated on the display of the drive modules.
- **FAULT turned OFF.** The led off indicates that there is no error and that all mains phases are OK.
- **BALLAST turned ON.** The amber led is lit when the energy dissipating Ballast circuit is activated.
- **DC BUS ON.** The green led indicates that the module is supplying all its power at the bus.

**INFORMATION.** For further detail on these indicator lights, see the combination table for interpretation in the description of the E305 code on the error listing shown in chapter 14 of the “man\_dds\_soft.pdf” manual.

### Ballast resistor selection

Non-regenerative power supplies PS-65A have three dip-switches on top, next to the terminal strip for mains connection (see figure) for selecting the external Ballast resistor. Refer to the attached table to make the type selection properly according to the setting of the switches while the i2t protection stays enabled.

Selecting “internal resistor or RM-15 module (already discontinued)” implies disabling the I2t protection. There is no risk of destroying the resistor because they both carry their own thermostat for their protection.

Selecting “resistor disabled” implies disabling the I2t protection. There is a risk of destroying the resistor without warning. Select only this switch setting when installing a resistor of more power than the ones supplied by FAGOR.

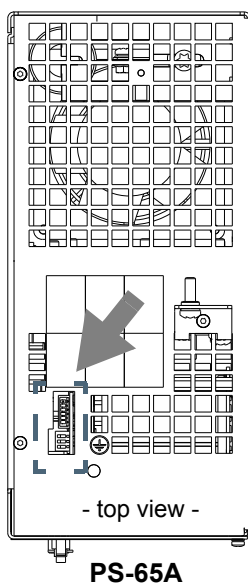

Model currently in the catalog

T. H2/3 Layout of the switch after selecting the resistor.

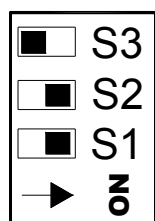

S3	S2	S1	RESISTOR
OFF	OFF	OFF	Internal
OFF	OFF	ON	2x ER+TH-18/1100
OFF	ON	OFF	2x ER+TH-18/1000+FAN
OFF	ON	ON	2x ER+TH-18/1800
ON	OFF	OFF	2x ER+TH-18/2200
ON	ON	OFF	2x RM-15 (discontinued)
ON	OFF	ON	DISABLED or 2x ER+TH-18/1500+FAN or 2x ER+TH-18/2000+FAN
ON	ON	ON	DISABLED or 2x ER+TH-18/1500+FAN or 2x ER+TH-18/2000+FAN

■ represents the moving element of the switch in the figure.

#### Example.

For the switch combination shown in the figure and verified in the table, the Ballast Resistor selected would correspond to the 2x ER+TH-18/1800.

S3	S2	S1	RESISTOR
OFF	ON	ON	2x ER+TH-18/1800



DDS  
HARDWARE

Ref.1310

**PS-25B4 module****Technical data****T. H2/4** Technical characteristics.

	<b>PS-25B4</b>
Power supply (Vmains)	Three-phase 50/60 Hz, with a voltage range between 400-10% and 460+10% V AC
Mains power consumption (400 V AC)	36 Arms
Maximum connection cable section	10 mm <sup>2</sup>
Power bus voltage Vbus rated	565 V DC / 650 V DC
Rated (peak) output current <sup>1</sup>	45 A (135 A, 1 s)
Rated (peak) output power	25 kW (75 kW, 1 s)
Internal Ballast resistance (power) <sup>1</sup>	16.5 Ω (500 W)
Energy pulse to be dissipated	6 kW (0.2 s)
Ballast circuit on / off	768 V DC / 760 V DC
Minimum external Ballast resistance	16.5 Ω
Filter capacity	705 μF, 900 V DC
Energy stored in the capacitors	0.5 C·V <sup>2</sup>
Maximum "SYSTEM OK" contact voltage	125 V AC, 150 V DC
Maximum "SYSTEM OK" contact current	1 A
Width	77 mm (3.03 in)
Approx. mass	6.0 kg (13.2 lb)
Power dissipated at maximum load	180 W

<sup>1</sup> See derating curves in case of high temperatures.

<b>Connection of the auxiliary power supply</b>	
Output voltage, maximum current	24 V DC (5 %), 10 A
Input voltage	Between 400 (-10%) and 460 (+10%) V AC 50/60 Hz
Mains consumption	0.72 A (400 V AC); 0.63 A (460 V AC)
Maximum Inrush current	23.9 A (460 V AC)
Bus consumption	0.485 A (565 V DC); 0.44 A (650 V DC)
Maximum voltage at the bus	790 V DC

**T. H2/5** Ambient conditions and other characteristics.

	<b>PS-25B4</b>
Ambient temperature <sup>1</sup>	5°C / 45°C (41°F / 113°F)
Storage temperature	-20°C / 60°C (-4°F / 140°F)
Maximum humidity	< 90% ( non condensing at 45°C / 113°F )
Maximum altitude without loss of features	1000 m (3281 ft) above sea level
Operating vibration	0.5 G
Shipping vibration	2 G
Sealing	IP 20
Protections	Over-voltage, heat-sink temperature, hardware error, Ballast overload.

<sup>1</sup> See derating curves in case of high temperatures.

**2.**

**POWER SUPPLIES**  
Non-regenerative power supplies

**FAGOR** 

**DDS  
HARDWARE**

**Ref.1310**

# 2.

**POWER SUPPLIES**  
Non-regenerative power supplies

## Power diagram

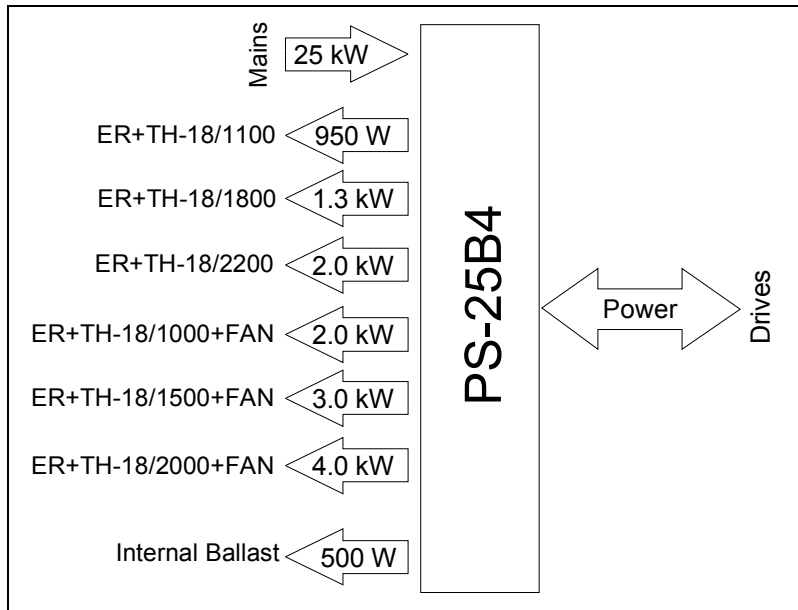

### F. H2/5

Power diagram.

## Block diagram

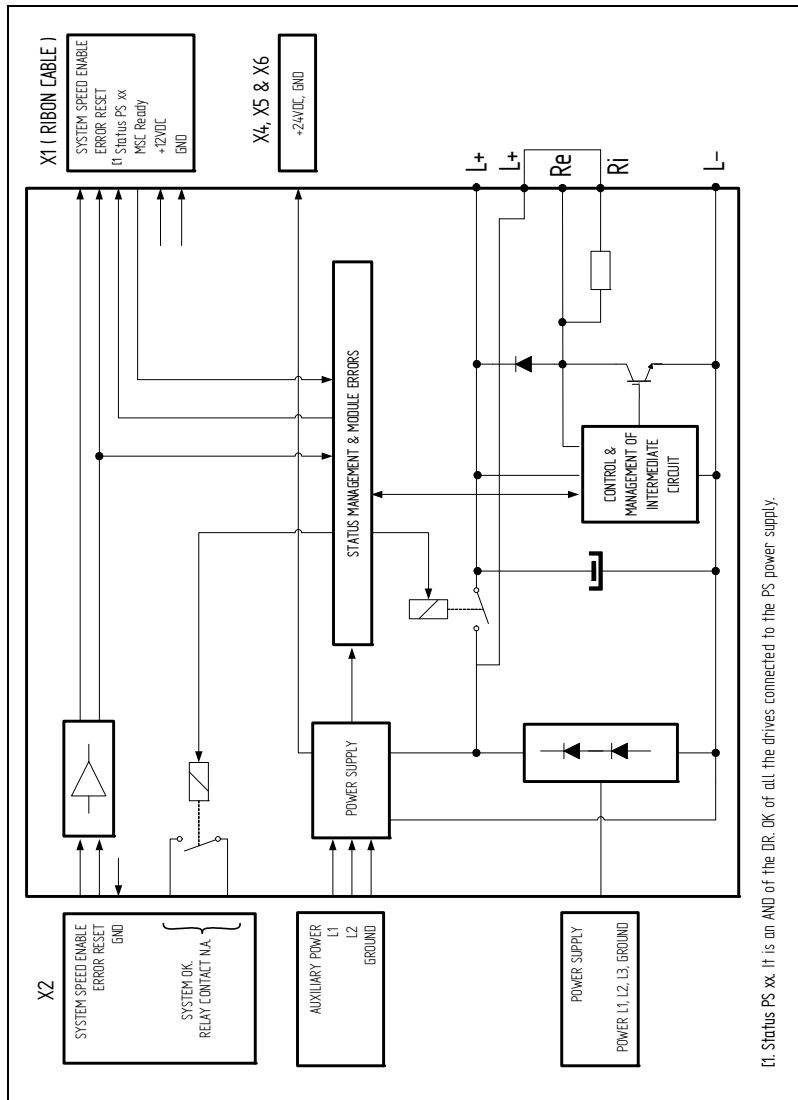

†1. Status PS xx. It is an AND of the DR. OK of all the drives connected to the PS power supply.

### F. H2/6

Block diagram.



DDS  
HARDWARE

Ref.1310

### PS-25B4. Connector description

The non-regenerative power supply PS-25B4 has the following connectors:

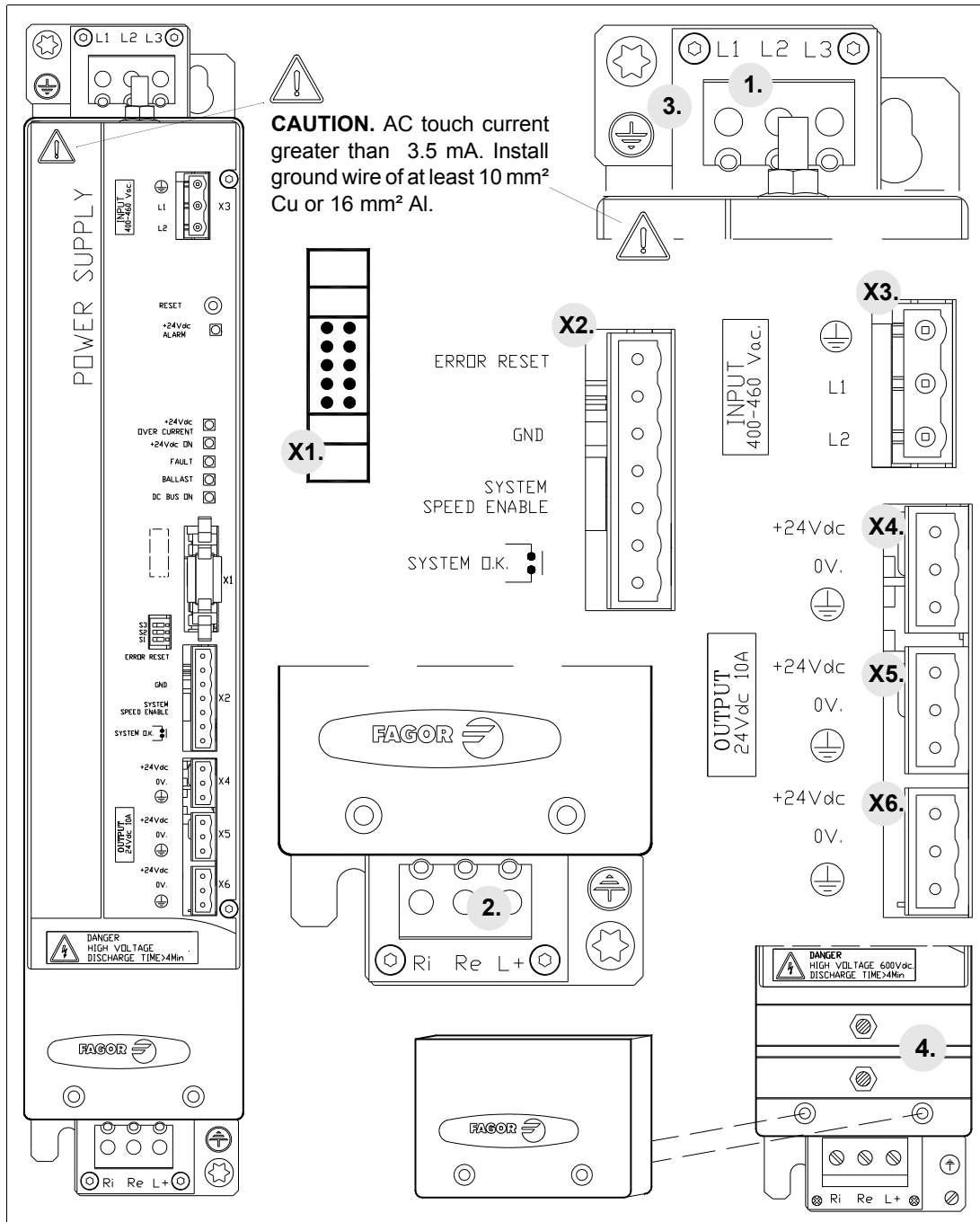

#### F. H2/7

Connectors of the PS-25B4 power supply.

1. Power connector for the three-phase mains.
2. Power connector for the external Ballast resistor connection.
3. Ground connection for the mains cable.
4. Power Bus supplying power to the drive modules through metal bars.
- X1. Connector for inter-module communication.
- X2. Connector for the basic control signals.
- X3. Input connector supplying from mains to the auxiliary power supply integrated into the module. The mains power is received through it. It admits a voltage between 400 and 460 V AC.
- X4. Output connector of the auxiliary 24 V DC power supply integrated into the module.
- X5. Output connector of the auxiliary 24 V DC power supply integrated into the module.
- X6. Output connector of the auxiliary 24 V DC power supply integrated into the module.

## 2.

**POWER SUPPLIES**  
Non-regenerative power supplies



DDS  
HARDWARE

Ref.1310

# 2.

**POWER SUPPLIES**  
Non-regenerative power supplies

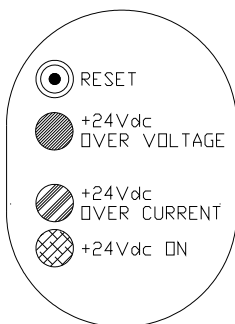
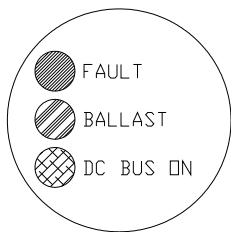

### Lights indicating the status of the main power supply

The non-regenerative power supply PS-25B4 has the following lights on the front panel to indicate the status of the main power supply.

- **FAULT blinking.** The blinking red led indicates that **there are no errors** and that **one or several mains phases are missing**.
- **FAULT turned ON.** The steady red led on indicates that there is an error. The error is indicated on the display of the drive modules.
- **FAULT turned OFF.** The led off indicates that there is no error and that all mains phases are OK.
- **BALLAST turned ON.** The amber led is lit when the energy dissipating Ballast circuit is activated.
- **DC BUS ON.** The green led indicates that the module is supplying all its power at the bus.

### Lights indicating the status of the auxiliary power supply

The non-regenerative power supply PS-25B4 has the following status indicating lights on the front panel of the module for the integrated internal auxiliary power supply.

- **RESET.** Initializes the auxiliary 24 V DC power supply.
- **OVER VOLTAGE.** The red led indicates that there is an over-voltage error at the 24 V DC output or due to over-temperature.
- **OVER CURRENT.** The red led indicates that there is an over-current error at the 24 V DC output.
- **ON.** The green led it indicates that there are 24 V DC at the output.

### Ballast resistor selection

**NOTE.** The model with two selection switches has been discontinued. If you still have this model, refer to this section to configure the selection of the Ballast resistor. If you have the model with three switches, see the next page.

The non-regenerative power supply PS-25B4 had two switches on the front and next to connector X1 (see figure) for selecting the external Ballast resistor. If you have a model like this one, refer to the attached table to select the right resistor model according to the setting of the switches that enables the "I<sup>2</sup>t" protection. Remember that selecting the internal resistor or having the RM-15 module means disabling the "I<sup>2</sup>t" protection because they both include their own thermostat for their own protection.

### T. H2/6 Layout of the ballast resistor selector switches

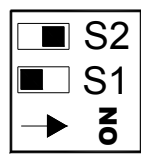

S1	S2	RESISTOR
ON	ON	ER-18/1100
OFF	ON	ER-18/1800 or ER+TH-18/1000+FAN
ON	OFF	ER+TH-18/2200
OFF	OFF	RM-15 or internal R

■ represents the moving element of the switch in the figure.

#### Example.

For the switch combination shown in the figure and verified in the table, the selected ballast resistor would correspond to the ER-18/1800 or ER+TH-18/1000+FAN.

S1	S2	RESISTOR
OFF	ON	ER-18/1800 or ER+TH-18/1000+FAN



Discontinued model

PS-25B4



DDS  
HARDWARE

Ref.1310

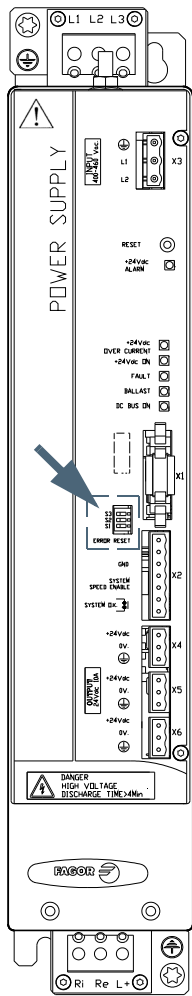

**PS-25B4**

Model currently in the catalog

**NOTE.** This is the current model with three micro-switches to configure the selection of the Ballast resistor installed.

The non-regenerative power supply PS-25B4 has three switches on the front and next to connector X1 (see figure) for selecting the external Ballast resistor. If you have a model like this one, refer to the attached table to select the right resistor model according to the setting of the switches that enables the “I<sup>2</sup>t” protection. Remember that selecting the internal resistor or having the RM-15 module means disabling the “I<sup>2</sup>t” protection because they both include their own thermostat for their own protection.

**T. H2/7** Layout of the ballast resistor selector switches

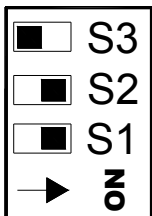

S3	S2	S1	RESISTOR
OFF	OFF	OFF	Internal
OFF	OFF	ON	ER+TH-18/1100
OFF	ON	OFF	ER+TH-18/1000+FAN
OFF	ON	ON	ER+TH-18/1800
ON	OFF	OFF	ER+TH-18/2200
ON	ON	OFF	RM-15 (discontinued)
ON	OFF	ON	DISABLED or ER+TH-18/1500+FAN or ER+TH-18/2000+FAN
ON	ON	ON	DISABLED or ER+TH-18/1500+FAN or ER+TH-18/2000+FAN

■ represents the moving element of the switch in the figure.

**Example.**

For the switch combination shown in the figure and verified in the table, the ballast resistor selected would correspond to the ER+TH-18/1800.

S3	S2	S1	RESISTOR
OFF	ON	ON	ER+TH-18/1800

**2.**

**POWER SUPPLIES**  
Non-regenerative power supplies



**DDS  
HARDWARE**

Ref.1310

# 2.

**POWER SUPPLIES**  
Non-regenerative power supplies

## Power connectors

### Terminal strip for mains connection

When connecting the power supplies to mains through terminals L1, L2 and L3, the phases may be connected in any order.

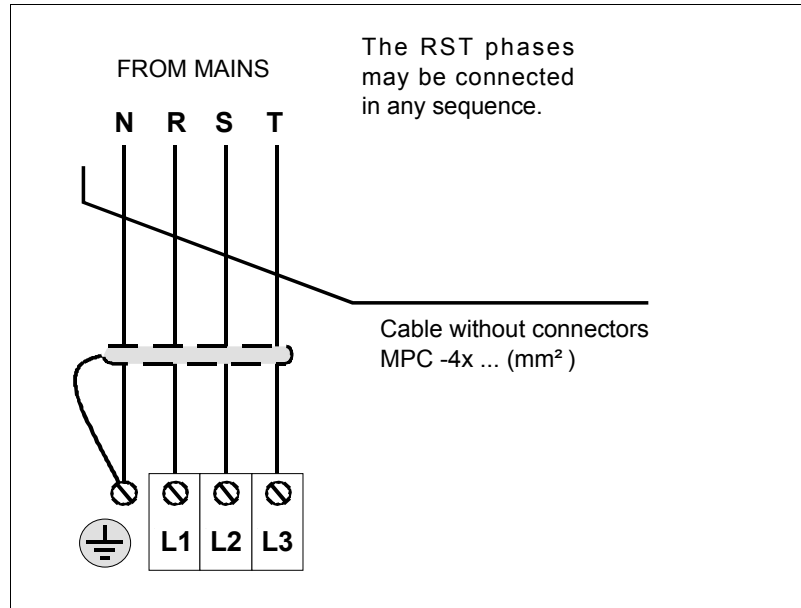

#### F. H2/8

Terminal strip for connection to mains.

The ground connection of the cable shield is made from the vertical plate next to the terminal strip.

The following table shows the values for gap, tightening torque (wire entry holes) and other data regarding these power screw-on terminals:

#### T. H2/8 Technical data of the mains connection terminals.

Connector data	PS-25B4	PS-65A
Gap (mm)	10.16	-
Min/max tightening torque (N·m)	1.2/1.5	6/8
Screw thread	M4	M6
Min./max. section (mm <sup>2</sup> )	0.5/16	16/50
Rated current I <sub>n</sub> (A)	76	150
Wire data		
Length to strip (mm)	10	24



**MANDATORY.** As for possible high leak currents, use a protection ground wire with a cross section of at least 10 mm<sup>2</sup> (Cu) or 16mm<sup>2</sup> (Al) or two protection ground wires with the same cross section as that of the wires connected to the power supply terminals. Comply with local regulations on grounding.



**MANDATORY.** The equipment must be protected with fuses on the three-phase supply lines L1, L2 and L3. Follow the instructions given in chapter 6. **POWER LINE CONNECTION** of this manual.



DDS  
HARDWARE

Ref.1310

**Terminal strip to connect the Ballast resistor**

The power supply is supplied from factory with a wire jumper between terminals Ri and L+. This configuration of the power supply means that it comes from the factory with its internal Ballast resistor.

However, if with this internal resistor it is not possible to dissipate enough power (e.g. when braking), the configuration must be modified so the power supply can work with an external ballast resistor capable of dissipating that energy. Remove the wire between terminals Ri and L+ and connect the proper external resistor between terminals Re and L+. See the diagram in the figure.

Removing the jumper between Ri and L+ and not connecting an external ballast resistor generates error code E215 or E304 on the display. On PS-25B4 power supplies, the power bus will not be charged.

Here is a graphic representation of the two possible configurations:

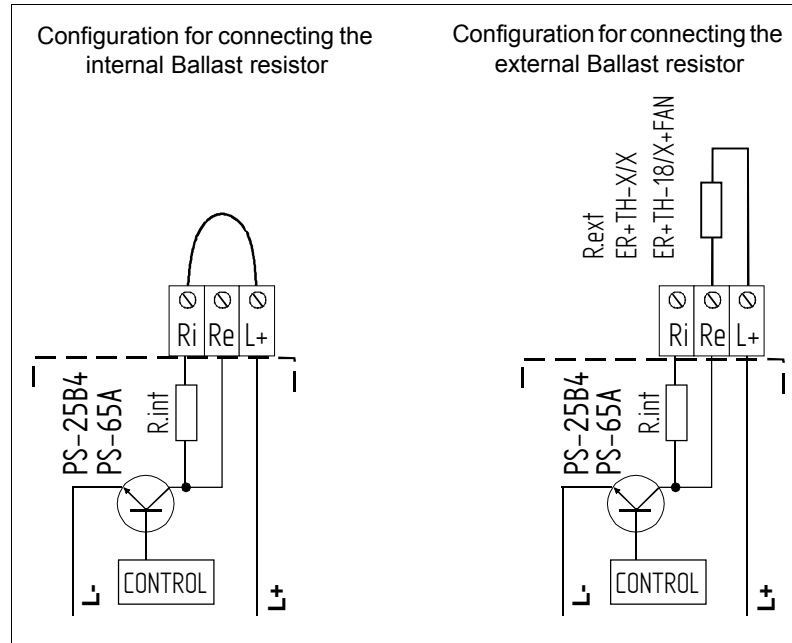

**F. H2/9**

Ballast resistor connection configurations.

The following table shows the values for gap, tightening torque (wire entry holes) and other data regarding the screw-on terminals of the ballast resistor according to power supply model:

**T. H2/9** Technical data of the connection terminals of the ballast resistor.

Connector data	PS-25B4	PS-65A
Gap (mm)	10.16	-
Min/max tightening torque (Nm)	1.2/1.5	2/2.3
Screw thread	M4	M5
Min./max. section (mm <sup>2</sup> )	0.5/16	0.5/25
Rated current In (A)	76	76
Wire data		
Length to strip (mm)	10	16

These power supply carry a protection against over-temperature which triggers error E301 on the display and stops its operation when reaching 105 °C (221 °F).

**2.**

**POWER SUPPLIES**  
Non-regenerative power supplies



**DDS  
HARDWARE**

**Ref.1310**

# 2.

POWER SUPPLIES  
Non-regenerative power supplies

## Derating curves

The power these resistors can dissipate depends on the ambient temperature according to the following derating curves.

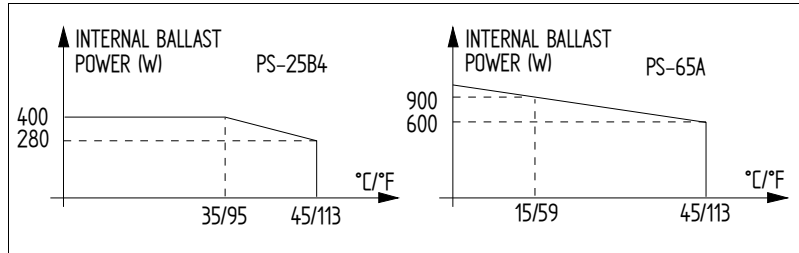

### F. H2/10

Derating curves of the ballast dissipation power on non-regenerative power supplies.

### Connection terminals for the power DC bus

At the bottom of the module, covered by a screwed on lid, the power supply offers the terminal for the power bus. This bus provides a dc voltage output of 565 V DC (when the mains voltage is 400 V AC) that feeds all the drive modules that are part of the servo drive system.



**MANDATORY.** All the modules powered by the same power supply must be joined by the same power bus. This condition is a must for the system to work.



**WARNING.** Never connect the power bus while the system is running. There are voltages of about 600 V DC!



**WARNING.** Please note that the STO (Safe Torque Off) safety function does not imply an electrical power off. There is still voltage at the DC bus. Ignoring this warning may cause electric shock.

Two plates are supplied with each module to join them with the adjacent drive modules.



**MANDATORY.** The tightening torque of these terminals must be between 2.3 and 2.8 Nm. This point is very important to ensure good electrical contact between modules.

FAGOR power supplies have a Soft Start for charging the power bus.

The soft start begins when two necessary and sufficient conditions are verified:

- No errors on any of the modules connected through the internal bus (connector X1)
- Presence of the three mains phases at the input of the module.



**INFORMATION.** For PS-25B4 power supplies, it is enough to have two mains phases.

This startup process begins when the FAULT indicator stops blinking and ends when the status indicator DC BUS ON turns on.



DDS  
HARDWARE

Ref.1310



**WARNING.** Before handling these leads, proceed in the following order:

- Stop the motors
- Disconnect the mains voltage at the electrical cabinet.
- Wait, before handling these leads. The power supply module needs time to decrease the voltage of the power bus down to safe values (< 42 V DC). The green indicator DC BUS ON being turned OFF does not mean that the power bus may be handled or manipulated.
- The discharge time depends on the number of elements connected and it is about 4 minutes.



**WARNING.** Never connect in parallel the power buses of different power supplies.



**MANDATORY.** Install an auxiliary power supply APS-24 (24 V DC, 10 A) to the DC bus of any DDS system with non-regenerative power supply PS-65A (mandatory) or PS-25B4 (suggested, not mandatory).



**INFORMATION.** Do not install external protection fuses in these power lines of the auxiliary power supply. They are already integrated in the power supply itself.

Remember that the purpose of connecting an auxiliary power supply APS-24 to the DC bus of a DDS system is to ensure the supply to all the control circuits of the power supply and of the drive modules connected to the DC bus in case of a mains power outage in the auxiliary power supply ensuring a controlled stop of the moving axes instead of braking out of control by friction.

Bear in mind that the PS-65A power supplies do not come with internal auxiliary power supply for their own control circuits and for those of the modules connected to the DC bus as well as other elements like fans, etc. That is why it is a must to install the APS-24 auxiliary power supply to do the installation properly.

PS-25B4 power supplies do come with an internal auxiliary power supply (24 V DC and a total of 8 A, 192 W). Therefore, it is not a must to install an APS-24 next to them, but it is highly suggested because, sometimes, higher power may be required to feed the control circuits of the modules than what the internal auxiliary power supply can provide (when installing a lot of drive modules).

Observe that the APS-24 auxiliary power supply offers 3 outputs with 24 V DC and a total of 10 A, 240 W.

For further information about the auxiliary module APS-24, see chapter 4. **AUXILIARY MODULES** in this manual.

**2.**

**POWER SUPPLIES**  
Non-regenerative power supplies

**FAGOR**

**DDS  
HARDWARE**

**Ref.1310**

# 2.

POWER SUPPLIES  
Non-regenerative power supplies

## Other connectors

### X1 connector

The communication between all the modules that make up the DDS servo drive system is established through connector X1.

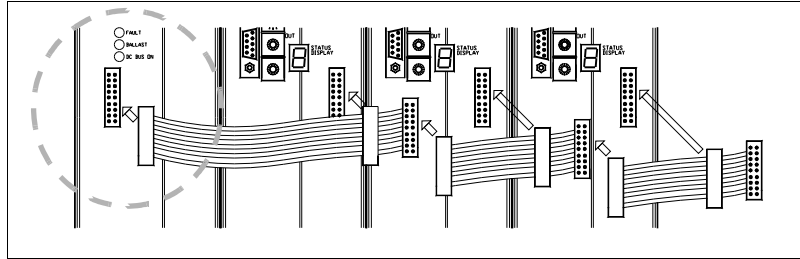

#### F. H2/11

Connection of the internal bus between modules through connector X1.

A ribbon cable is provided with each power supply or drive module for the connection.

### X2 connector

The power supply module may be controlled through connector X2.

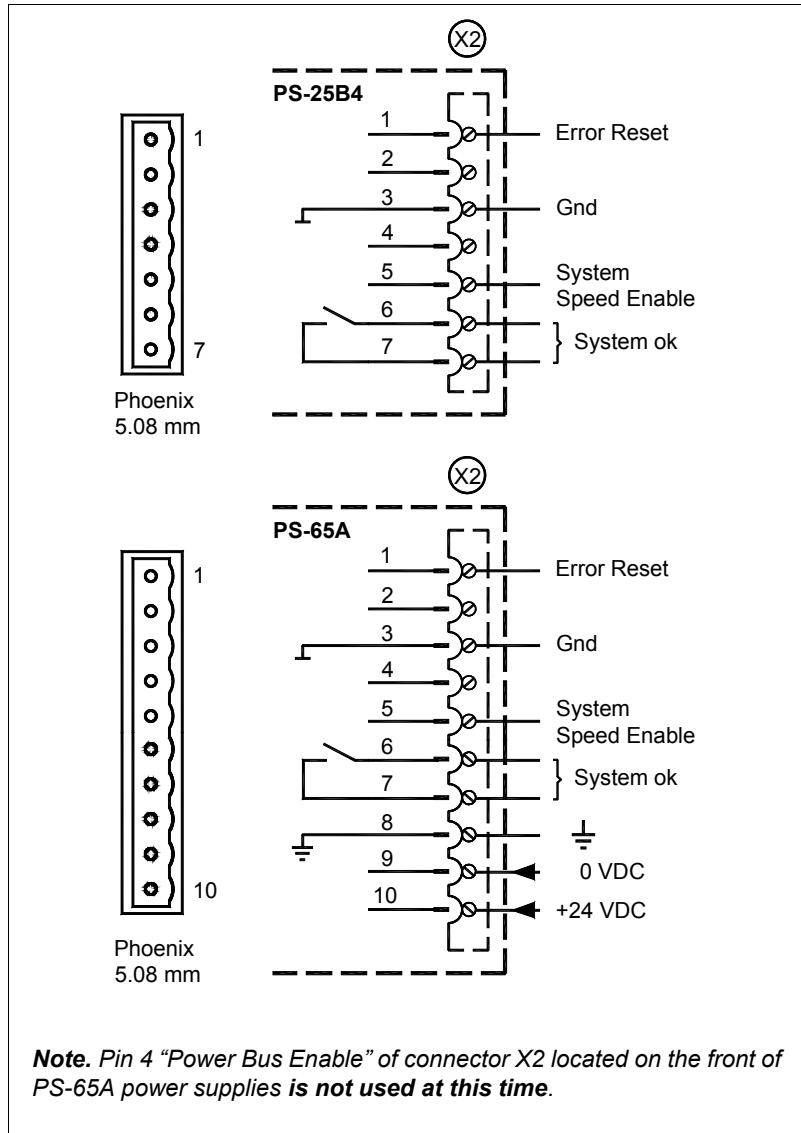

**Note.** Pin 4 "Power Bus Enable" of connector X2 located on the front of PS-65A power supplies is **not used at this time**.

#### F. H2/12

Control of the power supply module through connector X2.



DDS  
HARDWARE

Ref.1310

The internal circuits of the non-regenerative power supplies PS-65A require an external 24 V DC supply. This is why its connector X2 has three more pins than for the PS-25B4 power supply that integrates an auxiliary power supply.

The internal circuits are protected with a 1.25 A fuse.

The following table shows the values for gap, tightening torque, sections and other data of the plug-in connector for X2.

**T. H2/10** Characteristics of the pins of connector X2.

Connector data	PS-25B4	PS-65A
Nr of poles	7	10
Gap (mm)	5.08	5.08
Min/max tightening torque (N·m)	0.5/0.6	0.5/0.6
Screw thread	M3	M3
Min./max. section (mm <sup>2</sup> )	0.2/2.5	0.2/2.5
Rated current I <sub>n</sub> (A)	12	12
<b>Wire data</b>		
Length to strip (mm)	7	7

The next table shows the signals and other considerations related to each pin of connector X2:

**T. H2/11** Description of the pins of connector X2.

1	Error RESET	System error RESET input (24 V DC ; 4.5-7 mA).
2	Not connected	N. C.
3	GND	0 volts reference for digital inputs. Error RESET (1) and System Speed Enable (5).
4	Not connected	N. C.
5	System Speed Enable	General system speed enable. (24 V DC ; 4.5-7 mA).
6	System OK	Contact indicating module status. It opens in case of failure.
7	System OK	Limit 1 A at 24 V.
8	Chassis	Chassis connection (only on PS-65A power supplies)
9	0 V DC	Voltage supply of the control circuits (only on PS-65A power supplies) between 21 V DC and 28 V DC. Max. consumption 1 A.
10	+ 24 V DC	

2.

**POWER SUPPLIES**  
Non-regenerative power supplies

**FAGOR** 

**DDS  
HARDWARE**

**Ref.1310**

# 2.

POWER SUPPLIES  
Non-regenerative power supplies

## X3, X4, X5 and X6 connectors

These connectors belong to the auxiliary power supply integrated into the main power supply PS-25B4.

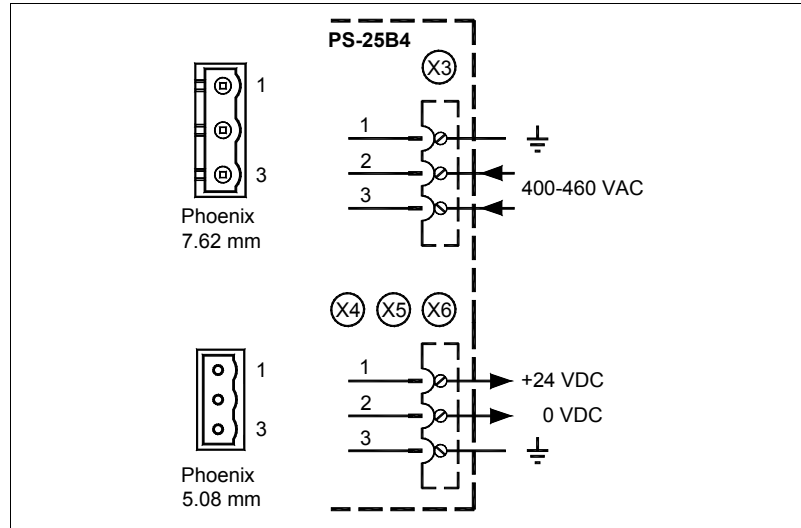

### F. H2/13

Connectors X3, X4, X5 and X6 of the auxiliary power supply integrated into the PS-25B4.

Connector X3 receives power from mains. It admits a voltage between 400 V AC and 460 V AC.



**INFORMATION.** There is no need to install external protection fuses in these power lines. They are already integrated into the power supplies.

This auxiliary power supply generates 24 V DC and its purpose is to feed the control circuits of the module itself. Also, it supplies up to 10 A of this dc voltage through connectors X4, X5 and X6. These three connectors are identical and offer greater connecting flexibility.

The gap and tightening torque and sections of the screws of the plug-in connectors for X3 and X4, X5, X6 are given by the table:

### T. H2/12 Data of the plug-in connector for X3.

Connector data	PS-25B4	
Nr of poles	3	
Gap (mm)	7.62	
Min/max tightening torque (N·m)	0.5/0.6	
Screw thread	M3	
Min./max. section (mm <sup>2</sup> )	0.2/2.5	
Rated current I <sub>n</sub> (A)	12	
<b>Wire data</b>		
Length to strip (mm)	7	

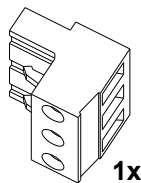

### T. H2/13 Data of the 3 identical plug-in connectors for X4, X5 and X6.

Data of each connector	PS-25B4	
Nr of poles	3	
Gap (mm)	5.08	
Min/max tightening torque (N·m)	0.5/0.6	
Screw thread	M3	
Min./max. section (mm <sup>2</sup> )	0.2/2.5	
Rated current I <sub>n</sub> (A)	12	
<b>Wire data</b>		
Length to strip (mm)	7	

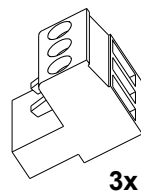

**INFORMATION.** In cases of micro-surges or total loss of mains power, this module guarantees stable and maintained 24 V DC while the motors are being stopped. This is an absolute must in order to comply with the CE requirement for the machine.



DDS  
HARDWARE

Ref.1310

## Module power-up

### 1. For PS-65A power supplies:

Supply 24 V DC to the control circuits of the power supply through pins 9 and 10 of connector X2.

### For PS-25B4 power supplies:

Apply power to the Auxiliary Power Supply from mains through pins 2 and 3 of connector X3; These will power the control circuits of the power supply and provide 24 V DC at connectors X4, X5 and X6.

### 2. The power supply checks the system status:

#### If the status is correct:

The **System Ok** contact closes (pins 6 and 7) and it stays closed while the control circuits are powered and no error comes up in any of the modules of the system.

The red FAULT indicator light blinks (it is not indicating an error because there are no phases yet).

#### If the status is not correct:

The red FAULT indicator light is permanently on (not blinking).

### 3. Apply power to the power supply:

Power is applied from mains through the power connectors on top of the power supply.

The soft start begins.

The red FAULT indicator light turns off.

### 4. green DC BUS ON light on:

After 4 seconds, the green DC BUS ON indicator light turns on meaning that the power bus has the proper dc voltage.

If for any reason an error is activated at the power supply module or at any drive module it supplies to, the system will act as follows:

1. The green indicator light DC BUS ON will turn off indicating that the power supply will stop supplying voltage to the power bus.



**DANGER.** When the DC BUS ON led turns off it may take about 4 minutes for the bus to discharge to a safe value (< 42 V DC) depending on the number of drive modules that are connected.

2. The red FAULT light will be on permanently.

With the Error RESET input (pin 1), it is possible to eliminate the errors at the drives that are part of the system - see chapter 14, resettable errors, of the "man\_dds\_soft.pdf" manual - and it acts as follows:

- Its state will be 0 Volt. Activating it with 24 V DC erases all the errors stored in the memory of each drive of the system.
- Should the cause of the error persist, the corresponding module will show the same error again and it will be necessary to turn the unit back on to eliminate the error if it is a serious error.

The System Speed Enable input (pin 5) is related to the Speed Enable inputs of the drive modules.

- The state of the System Speed Enable is usually 24 V DC.
- If the System Speed Enable pin is set to 0 V DC, all the drive modules joined together by the same internal bus will brake the motors that they control with the torque corresponding to the active acceleration ramp and when stopped or when reaching the time limit to stop (programmable with parameter GP3, see chapter 13 of the "man\_dds\_soft.pdf" manual), it cancels the motor torque.

The consumption of each input is between 4.5 and 7 mA.

# 2.

**POWER SUPPLIES**  
Non-regenerative power supplies

**FAGOR** 

**DDS  
HARDWARE**

**Ref.1310**

## 2.2 Regenerative power supplies

When referring to regenerative power supplies, we'll use XPS-25 and XPS-65. They all admit a mains voltage between 400-10% and 460+10% V AC and can return power back to mains. They are:

# 2.

**POWER SUPPLIES**  
Regenerative power supplies

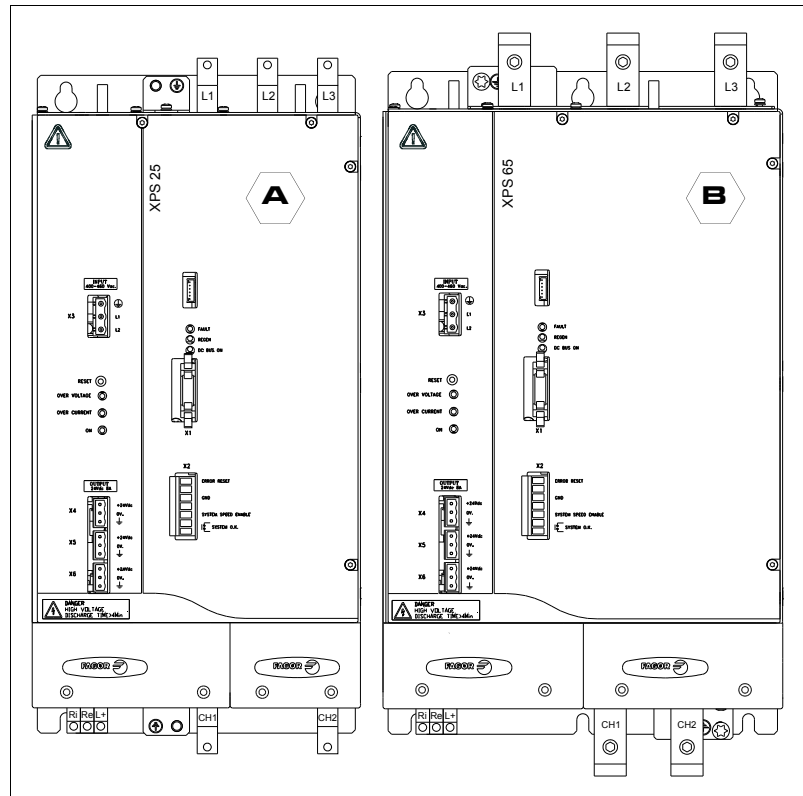

**F. H2/14**

Regenerative power supplies: **A.** XPS-25, **B.** XPS-65.

The **XPS-25A** supplies 25 kW and can return 20 kW to mains. It integrates an auxiliary 24 V DC power supply to feed the control circuits of the modular drives. Consequently, it will not need an APS-24 to perform this function.

The **XPS-65A** supplies 65 kW and can return 54 kW to mains. It integrates an auxiliary 24 V DC power supply to feed the control circuits of the modular drives. Consequently, it will not need an APS-24 to perform this function.



DDS  
HARDWARE

Ref.1310

## XPS modules

### Technical data

#### T. H2/14 Technical characteristics.

	XPS-25	XPS-65
Power supply (Vmains)	Three-phase 50/60 Hz, with a voltage range between 400-10% and 460+10% V AC	
Mains power consumption (400 V AC)	36 Arms	95 Arms
Maximum connection cable section	16 mm <sup>2</sup>	50 mm <sup>2</sup>
Power bus voltage VbusNom	565 V DC / 650 V DC	
Rated (peak) output current <sup>1</sup>	45 A (135 A, 1 s)	120 A (120 A, 1 s)
Rated (peak) output power	25 kW (55 kW, 1 s)	65 kW (108 kW, 1 s)
Regenerating circuit ON/OFF voltage	V mains · 1.414 + 150 V	
Rated regenerated current (returned to mains) <sup>1</sup> (400 V AC)	28 Arms	72 Arms
Rated regenerated power (returned to mains)	20 kW	54 kW
Isolated choke	CHOKE XPS-25	CHOKE XPS-65-A
Choke-drive cable (max length: 2 m)	16 mm <sup>2</sup>	50 mm <sup>2</sup>
Output voltage of the auxiliary power supply	24 V DC ± 5%	
Maximum current supplied	8 A at 24 V (192 W)	
Mains consumption to generate 24 V DC	0.72 A (400 V AC); 0.63 A (460 V AC)	
Internal Ballast resistance (power) <sup>1</sup>	18 Ω (520 W)	9 Ω (1800 W)
Energy pulse to be dissipated	18 kW (0.6 s)	kW
Ballast circuit ON/OFF	765 V DC / 755 V DC	
Minimum external Ballast resistance	18 Ω	9 Ω
Filter capacity	1175 μF, 900 V DC	2115 μF, 900 V DC
Energy stored in the capacitors	0.5 C V <sup>2</sup>	
Maximum "SYSTEM OK" contact voltage	125 V AC, 150 V DC	
Maximum "SYSTEM OK" contact current	1 A	
Width	194 mm (7.64 in)	234 mm (9.21 in)
Approx. mass	14 kg (31 lb)	19 kg (42 lb)
Power dissipated at maximum load	180 W	350 W

<sup>1</sup> See derating curves in case of high temperatures.

#### T. H2/15 Ambient conditions and other characteristics.

	XPS-25	XPS-65
Ambient temperature <sup>1</sup>	5°C / 45°C (41°F / 113°F)	
Storage temperature	- 20°C / 60°C (- 4°F / 140°F)	
Maximum humidity	< 90% ( non condensing at 45°C / 113°F )	
Maximum altitude without loss of features	1000 m (3281 ft) above sea level	
Operating vibration	0.5 G	
Shipping vibration	2 G	
Sealing	IP 20	
Protections	Over-voltage, over-current, hardware error, ambient temperature.	

<sup>1</sup> See derating curves in case of high temperatures.

2.

POWER SUPPLIES  
Regenerative power supplies



DDS  
HARDWARE

Ref.1310

# 2.

**POWER SUPPLIES**  
Regenerative power supplies

## Power diagram

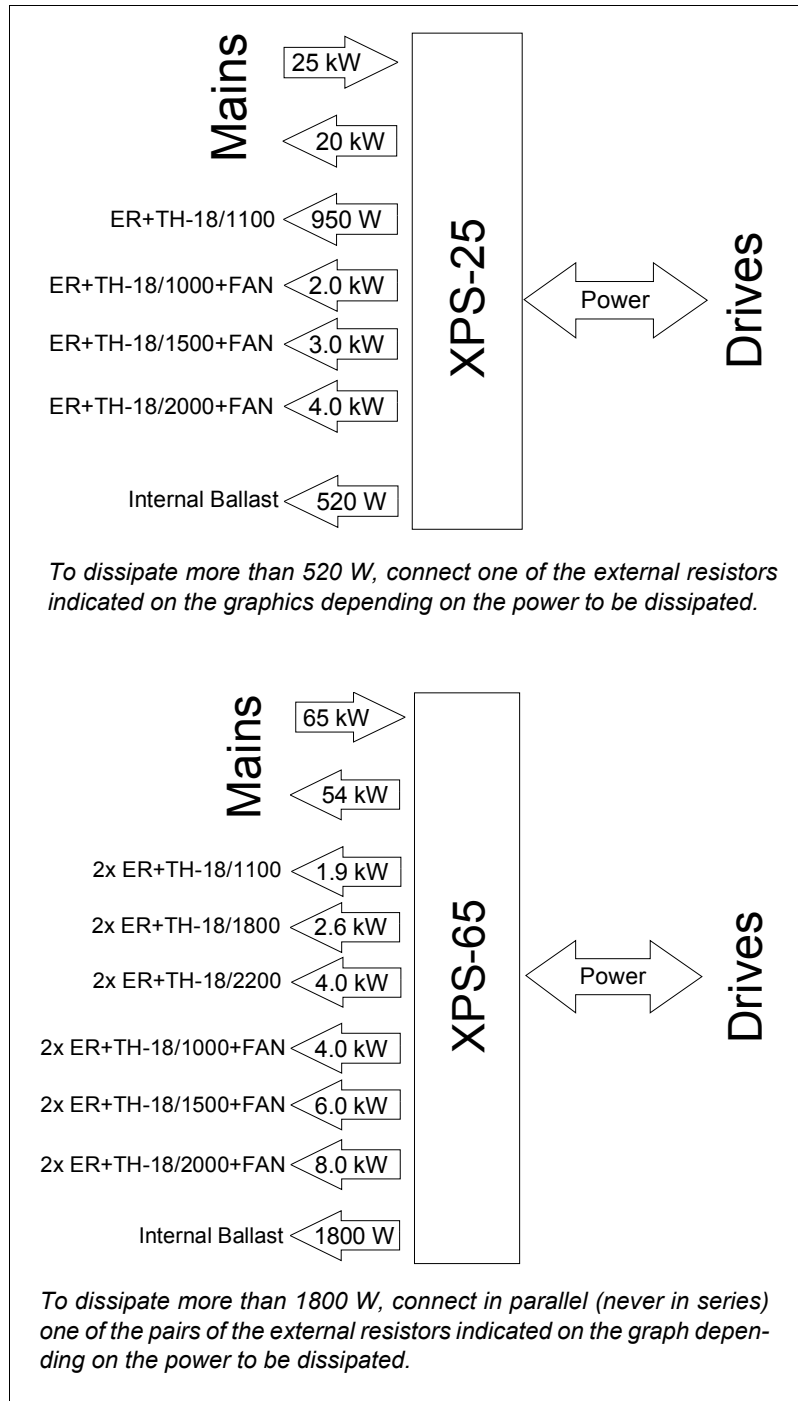

### F. H2/15

Power diagram.



DDS  
HARDWARE

Ref.1310

**Block diagram**

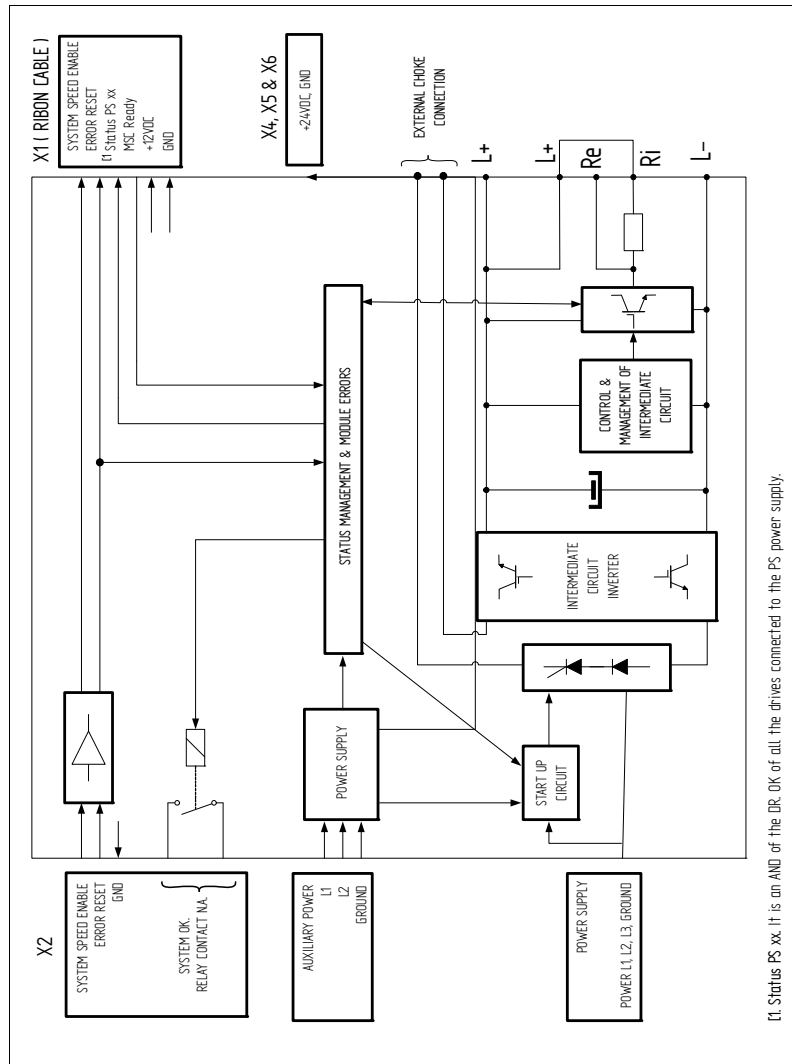

**F. H2/16**

Block diagram.

**2.**

**POWER SUPPLIES**  
Regenerative power supplies



**DDS  
HARDWARE**

**Ref.1310**

### XPS-25. Connector description

The regenerative power supply XPS-25 has the following connectors:

**2.**  
**POWER SUPPLIES**  
Regenerative power supplies

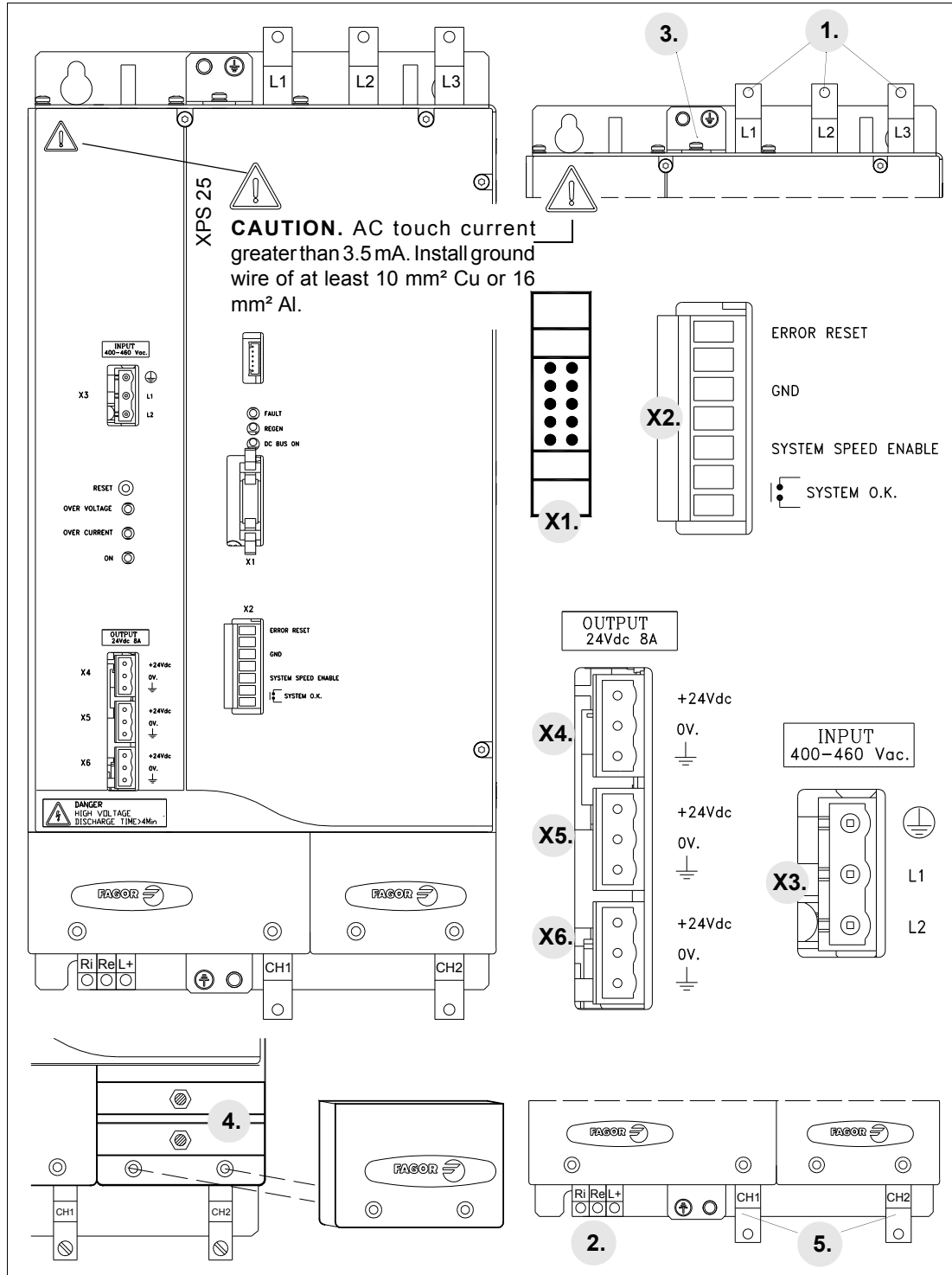

F. H2/17

Connectors of the PS-25 power supply.

1. Power connector for the three-phase mains.
2. Power connector for the external Ballast resistor connection.
3. Ground connection for the mains cable.
4. Power Bus supplying power to the drive modules through metal bars.
5. Connectors for the choke of the XPS-25.
- X1. Connector for inter-module communication.
- X2. Connector for the basic control signals.
- X3. Input connector supplying from mains to the auxiliary power supply integrated into the module. The mains power is received through it. It admits a voltage between 400 V AC and 460 V AC.
- X4. Output connector of the auxiliary 24 V DC power supply integrated into the module.
- X5. Output connector of the auxiliary 24 V DC power supply integrated into the module.
- X6. Output connector of the auxiliary 24 V DC power supply integrated into the module.



DDS  
HARDWARE

Ref.1310

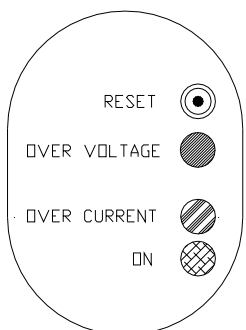
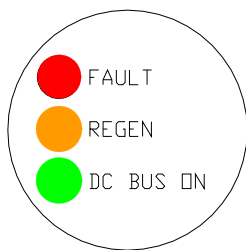

### Lights indicating the status of the main power supply

The regenerative power supply XPS-25 has the following lights on the front panel to indicate the status of the main power supply:

- **FAULT blinking.** The blinking red led indicates that **there are no errors** and that **one or several mains phases are missing**.
- **FAULT turned ON.** The steady red led on indicates that there is an error. The error is indicated on the display of the drive modules.
- **FAULT turned OFF.** The led off indicates that there is no error and that all mains phases are OK.
- **REGEN.** The led is lit when the module is working in energy regenerating mode.
- **DC BUS ON.** The green led indicates that the module is supplying all its power at the bus.

**INFORMATION.** For further detail on these indicator lights, see the combination table for interpretation in the description of the E305 on the error listing shown in chapter 14. **ERROR CODES AND MESSAGES** of the “man\_dds\_soft.pdf” manual.

### Lights indicating the status of the auxiliary power supply

The regenerative power supply XPS-25 has the following lights on the front panel to indicate the status of the integrated auxiliary power supply:

- **RESET.** Initializes the auxiliary 24 V DC power supply.
- **OVER VOLTAGE.** The red led indicates that there is an over-voltage error at the 24 V DC output or due to over-temperature.
- **OVER CURRENT.** The red led indicates that there is an over-current error at the 24 V DC output.
- **ON.** The green led it indicates that there are 24 V DC at the output.

# 2.

**POWER SUPPLIES**  
Regenerative power supplies

**FAGOR**

**DDS  
HARDWARE**

**Ref.1310**

### XPS-65. Connector description

The regenerative power supply XPS-65 has the following connectors:

# 2.

**POWER SUPPLIES**  
Regenerative power supplies

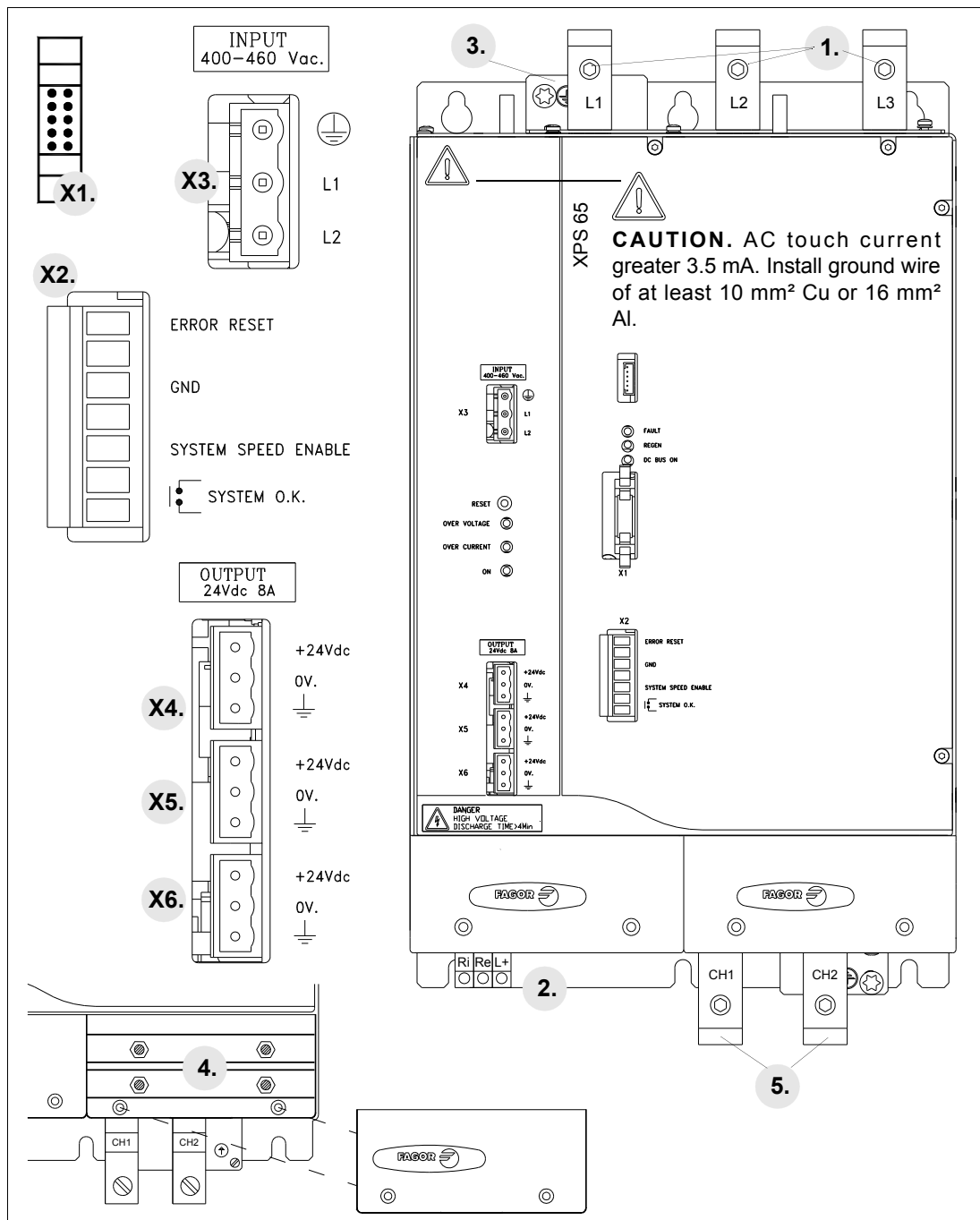

#### F. H2/18

Connectors of the PS-65 power supply.

1. Power connector for the three-phase mains.
  2. Power connector for the external Ballast resistor connection.
  3. Ground connection for the mains cable.
  4. Power Bus supplying power to the drive modules through metal bars.
  5. Connectors for the choke of the XPS-65.
- X1. Connector for inter-module communication.  
 X2. Connector for the basic control signals.  
 X3. Input connector supplying from mains to the auxiliary power supply integrated into the module. The mains power is received through it. It admits a voltage between 400 and 460 V AC.  
 X4. Output connector of the auxiliary 24 V DC power supply integrated into the module.  
 X5. Output connector of the auxiliary 24 V DC power supply integrated into the module.  
 X6. Output connector of the auxiliary 24 V DC power supply integrated into the module.



DDS  
HARDWARE

Ref.1310

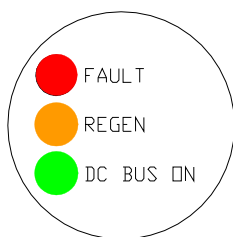

### Lights indicating the status of the main power supply

The regenerative power supply XPS-65 has the following lights on the front panel to indicate the status of the main power supply:

- **FAULT blinking.** The blinking red led indicates that **there are no errors** and that **one or several mains phases are missing**.
- **FAULT turned ON.** The steady red led on indicates that there is an error. The error is indicated on the display of the drive modules.
- **FAULT turned OFF.** The led off indicates that there is no error and that all mains phases are OK.
- **REGEN.** The led is lit when the module is working in energy regenerating mode.
- **DC BUS ON.** The green led indicates that the module is supplying all its power at the bus.



**INFORMATION.** For further detail on these indicator lights, see the combination table for interpretation in the description of the E305 on the error listing shown in chapter 14. **ERROR CODES AND MESSAGES** of the “man\_dds\_soft.pdf” manual.

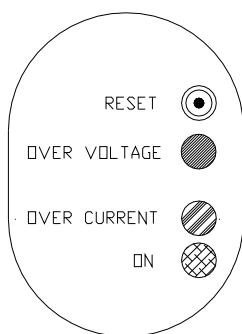

### Lights indicating the status of the auxiliary power supply

The regenerative power supply XPS-65 has the following lights on the front panel to indicate the status of the integrated auxiliary power supply:

- **RESET.** Initializes the auxiliary 24 V DC power supply.
- **OVER VOLTAGE.** The red led indicates that there is an over-voltage error at the 24 V DC output or due to over-temperature.
- **OVER CURRENT.** The red led indicates that there is an over-current error at the 24 V DC output.
- **ON.** The green led it indicates that there are 24 V DC at the output.

# 2.

**POWER SUPPLIES**  
Regenerative power supplies

**FAGOR**

**DDS  
HARDWARE**

**Ref.1310**

# 2.

**POWER SUPPLIES**  
Regenerative power supplies

## Power connectors

### Terminal strip for mains connection

When connecting the power supplies to mains, the phases may be connected in any order.

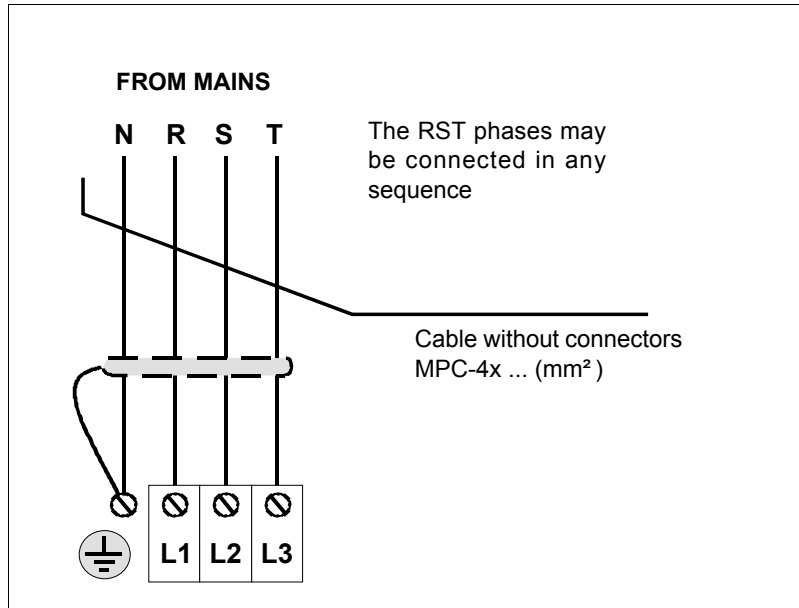

#### F. H2/19

Terminal strip for connection to mains.

The ground connection of the cable shield is made from the vertical plate next to the terminal strip.

The following table shows the values for gap, tightening torque, sections and other interesting data of the power feed-through terminal blocks:

#### T. H2/16 Technical data of the feed-through terminal blocks for mains connection

Connector data	XPS-25	XPS-65
Min/max tightening torque (N·m)	2.0/2.3	6/8
Screw thread	M5	M6
Min./max. section (mm <sup>2</sup> )	0.5/16	16/50
Rated current I <sub>n</sub> (A)	76	150
Wire data		
Length to strip (mm)	16	24



**MANDATORY.** As for possible high leak currents, use a protection ground wire with a cross section of at least 10 mm<sup>2</sup> (Cu) or 16mm<sup>2</sup> (Al) or two protection ground wires with the same cross section as that of the wires connected to the power supply terminals. Comply with local regulations on grounding.



**MANDATORY.** The equipment must be protected with fuses on the three-phase supply lines L1, L2 and L3. Follow the instructions given in chapter 6. **POWER LINE CONNECTION** of this manual.



DDS  
HARDWARE

Ref.1310

**Terminal strip to connect the Ballast resistor**

Regenerative power supplies also have a small Ballast Circuit for dissipating energy in case of an emergency. This emergency is issued when there is no connection to mains and the Ballast circuit activating voltage is exceeded. See table T. H2/14 in this chapter. Here are the two possible configurations:

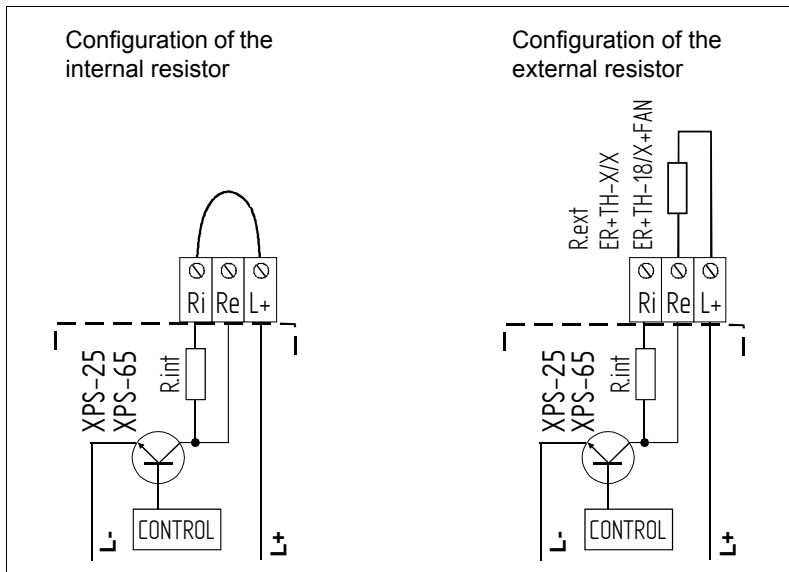

**F. H2/20**

Ballast resistor connection configurations.

Removing this jumper between Ri and L+ (factory setting) and not connecting an external resistor between Re and L+ generates error code E215 or E304 on the display.

The following table shows the values for gap, tightening torque, sections and other interesting data of the feed-through terminals blocks for connecting the ballast resistor:

**T. H2/17** Technical data of the feed-through terminal blocks for connecting the ballast resistor.

Connector data	XPS-25	XPS-65
Min/max tightening torque (N·m)	0.6/0.8	0.6/0.8
Screw thread	M3	M3
Min./max. section (mm <sup>2</sup> )	0.2/4	0.2/4
Rated current I <sub>n</sub> (A)	32	32

These power supplies carry a protection against over-temperature which triggers error E301 on the display when reaching 105 °C (221 °F).

**Derating curves**

The power that may be dissipated through the internal ballast resistor located inside the power supply XPS-25 depends on the ambient temperature as determined by the derating curve.

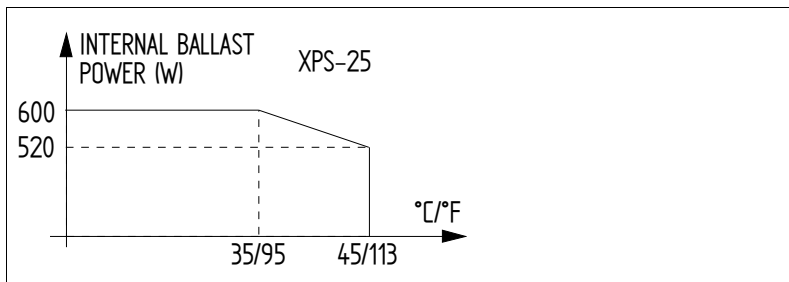

**F. H2/21**

Derating curve of regenerative power supplies XPS-25.

The performance of the internal Ballast resistor of the regenerative power supply XPS-65 does not suffer at high temperatures.

**2.**

**POWER SUPPLIES**  
Regenerative power supplies



**DDS  
HARDWARE**

**Ref.1310**

# 2.

**POWER SUPPLIES**  
Regenerative power supplies



DDS  
HARDWARE

Ref.1310

## Connection terminals for the power DC bus

At the bottom of the module, covered by the screwed-on lid on the right (see figure F. H2/17 and figure F. H2/18) the power supply offers the terminal for the power bus. This bus provides a dc voltage output of 565 V DC (when the mains voltage is 400 V AC) that feeds all the drive modules that are part of the DDS system.

All the modules powered with the same power supply must be connected through the power bus and this condition is a must to run it.



**WARNING.** Never connect the power bus while the system is running. There are voltages of about 600 V DC!

Two plates are supplied with each module to join them with the adjacent drive modules.



**MANDATORY.** The tightening torque of these terminals must be between 2.3 and 2.8 N·m. This point is very important to ensure good electrical contact between modules.

FAGOR power supplies have a soft-start for charging the power bus.

The soft start begins when these two conditions, that are necessary and sufficient, are met:

- No errors at the modules connected through the internal bus (connector X1).
- Presence of the three mains phases at the input of the module.

This startup process begins when the FAULT indicator stops blinking and ends when the status indicator DC BUS ON turns on.



**WARNING.** Before handling these leads, proceed in the following order:

- Stop the motors
- Disconnect the mains voltage at the electrical cabinet.
- Wait, before handling these leads. The power supply module needs time to decrease the voltage of the power bus down to safe values (< 42 V DC). The green indicator DC BUS ON being turned OFF does not mean that the power bus may be handled or manipulated.
- The discharge time depends on the number of elements connected and it is about 4 minutes.



**WARNING.** The power buses of different power supply modules must never be connected in parallel.



**MANDATORY.** If necessary, the auxiliary power supply APS-24 (24 V DC, 10 A) can only be connected to the DC bus of any regenerative power supply XPS when the version label of the APS-24 (located on top of it) indicates a reference newer than **PF 23A**.



**WARNING.** Never install an APS-24 to the DC bus of a DDS system with a regenerative power supply XPS if the reference of the APS-24 is PF 23A or older.

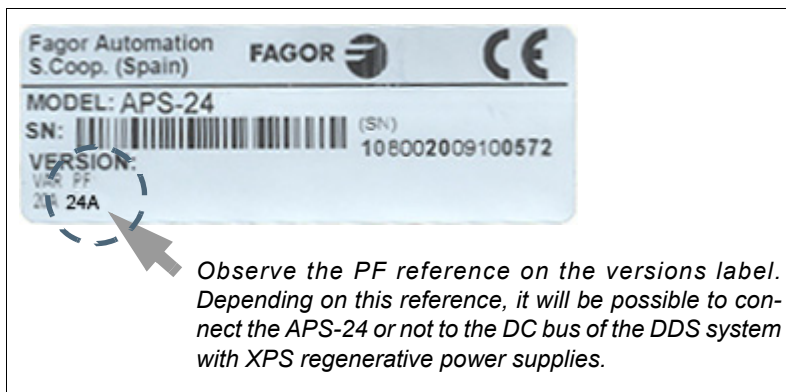

**F. H2/22**

Version label of the APS-24.



**INFORMATION.** It will not be necessary to install external protection fuses in these power lines of the auxiliary power supply. They are already integrated in the power supply itself.

Remember that the purpose of connecting an auxiliary power supply APS-24 to the DC bus of a DDS system is to ensure the supply to all the control circuits of the power supply and of the drive modules connected to the DC bus in case of a mains power outage in the auxiliary power supply ensuring a controlled stop of the moving axes instead of braking out of control by friction.

Bear in mind that although XPS power supplies come with an internal auxiliary power supply offering 3 outputs with 24V DC and a total of 8 A, 192 W, this power may not be enough to feed the control circuits of all the modules connected or other elements (e.g. a fan). That is why it may be necessary to also install an APS-24 auxiliary power supply to guarantee all the power needed.

The APS-24 auxiliary power supply offers 3 outputs with 24 V DC and a total of 10 A, 240 W.

For further information about the auxiliary module APS-24, see chapter 4. **AUXILIARY MODULES** in this manual.

**Choke connection terminals**

Regenerative power supplies XPS-25 and XPS-65 offer the connection terminals labeled CH1 and CH2 at the bottom of the module for connecting the choke. See figure **F. H2/17** and figure **F. H2/18**.

This inductive device is a must to limit the current circulating from the power bus to mains.

FAGOR supplies the choke XPS-25 and choke XPS-65-A for this application.

Use cables with the maximum section allowed 16 and 50 mm<sup>2</sup> y and shorter than 2 meters (6 feet). They do not have to be shielded.

**T. H2/18** Data of the feed-through terminal blocks for connecting the choke.

Connector data	CHOKE XPS-25	CHOKE XPS-65-A
Min/max tightening torque (N·m)	2.0/2.3	6.0/8.0
Screw thread	M5	M6
Min./max. section (mm <sup>2</sup> )	0.5/16	16/50
Rated current I <sub>n</sub> (A)	76	150



**WARNING.** The choke is an absolute must for the operation of a regenerative power supply. Installing the coil with an inductance other than the choke recommended in table **T. H2/14** may cause severe damage to the unit.

**2.**

**POWER SUPPLIES**  
Regenerative power supplies



**DDS  
HARDWARE**

**Ref.1310**

# 2.

**POWER SUPPLIES**  
Regenerative power supplies

## Other connectors

### X1 connector

The communication between all the modules that make up the DDS servo drive system is established through connector X1.

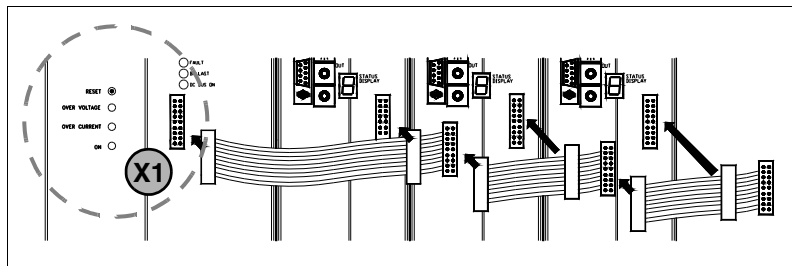

F. H2/23

Connection of the internal bus between modules through connector X1.

A ribbon cable is provided with each module (power supply or drive) for this connection.

### X2 connector

The power supply module may be controlled through X2.

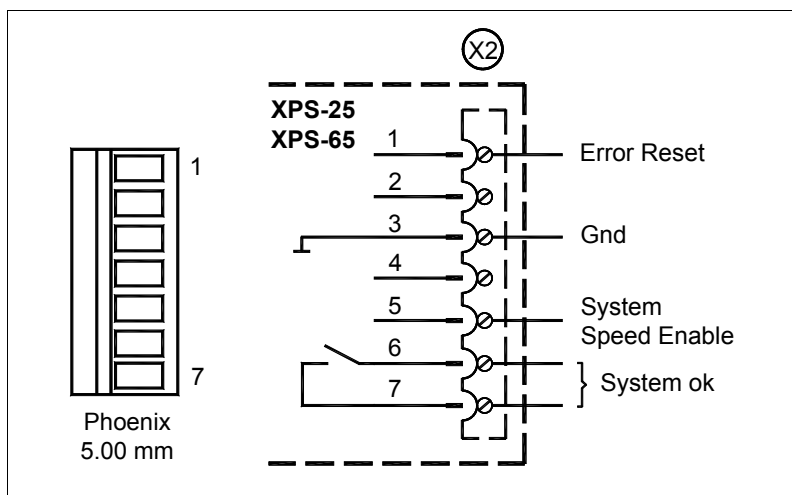

F. H2/24

Control of the power supply module through connector X2.

The internal circuits are protected with a 1.25 A fuse.



**MANDATORY.** Remember that the internal circuits of PS-65A non-regenerative power supplies must be powered by an external 24 V DC power supply, "APS-24"; that's why its control connector has three terminals more than connector X2 of the XPS.

The following table shows the values for gap, tightening torque, sections and other data of the plug-in connector for X2.

T. H2/19 Data of the plug-in connector for X2.

Connector data	XPS-25	XPS-65
Nr of poles	7	7
Gap (mm)	5.00	5.00
Min/max tightening torque (N·m)	0.5/0.6	0.5/0.6
Screw thread	M3	M3
Min./max. section (mm <sup>2</sup> )	0.2/2.5	0.2/2.5
Rated current I <sub>n</sub> (A)	12	12
<b>Wire data</b>		
Length to strip (mm)	7	7



DDS  
HARDWARE

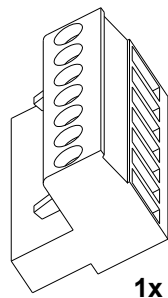

Ref.1310

The next table shows the signals and other considerations related to each pin of connector X2:

**T. H2/20** Description of the pins of connector X2.

1	Error RESET	System error RESET input (24 V DC; 4.5-7 mA).
2	N. C.	Not connected
3	GND	0 volts reference for digital inputs. Error RESET (1) and System Speed Enable (5).
4	N. C.	Not connected
5	System Speed Enable	General system speed enable. (24 V DC; 4.5-7 mA).
6	System OK	Contact indicating module status. It opens in case of failure. Limit 1 A at 24 V.
7	System OK	

**X3, X4, X5 and X6 connectors**

These connectors belong to the auxiliary power supply integrated into the main power supplies XPS-25 and XPS-65.

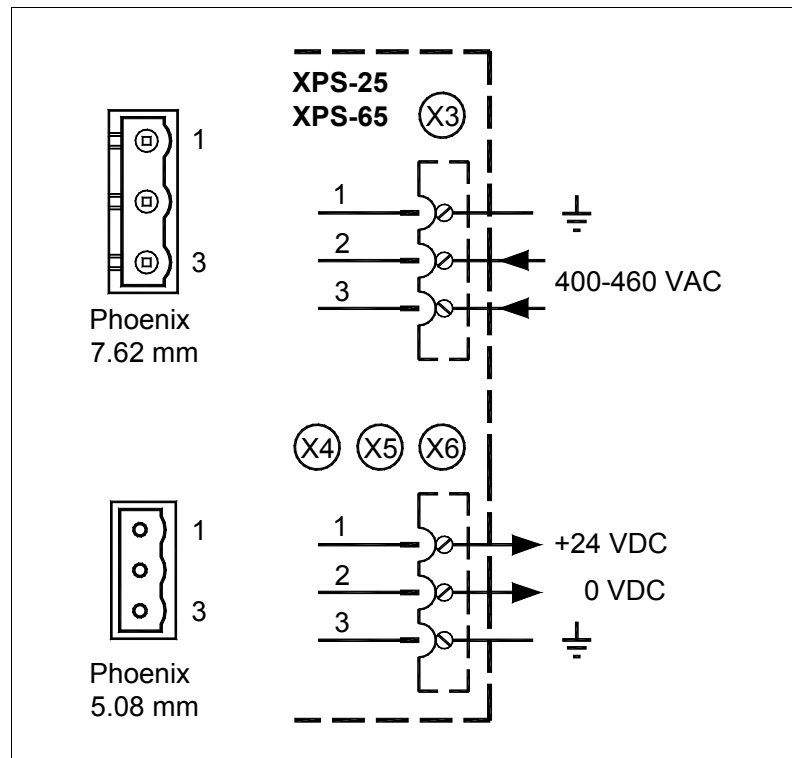

**F. H2/25**

Connectors X3, X4, X5 and X6 that belong to the auxiliary power supply integrated into regenerative power supplies XPS-25 and XPS-65.

Connector X3 receives power from mains. It admits a voltage between 400 and 460 V AC.

This auxiliary power supply generates 24 V DC and its purpose is to feed the control circuits of the module itself. Also, it supplies up to 8 A of this dc voltage through connectors X4, X5 and X6. These three connectors are identical and offer greater connecting flexibility.

**2.**

**POWER SUPPLIES**  
Regenerative power supplies



**DDS  
HARDWARE**

**Ref.1310**

# 2.

**POWER SUPPLIES**  
Regenerative power supplies

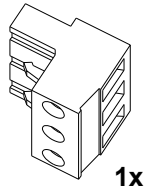

1x

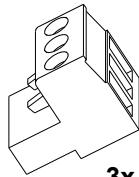

3x



The gap and tightening torque and sections of the screws of the plug-in connectors for X3 and X4, X5, X6 are given by the table:

**T. H2/21** Data of the plug-in connector for X3.

Connector data	XPS-25	XPS-65
Nr of poles	3	3
Gap (mm)	7.62	7.62
Min/max tightening torque (N·m)	0.5/0.6	0.5/0.6
Screw thread	M3	M3
Min./max. section (mm <sup>2</sup> )	0.2/2.5	0.2/2.5
Rated current I <sub>n</sub> (A)	12	12
<b>Wire data</b>		
Length to strip (mm)	7	7

**T. H2/22** Data of the 3 identical plug-in connectors for X4, X5 and X6.

Data of each connector	XPS-25	XPS-65
Nr of poles	3	3
Gap (mm)	5.08	5.08
Min/max tightening torque (N·m)	0.5/0.6	0.5/0.6
Screw thread	M3	M3
Min./max. section (mm <sup>2</sup> )	0.2/2.5	0.2/2.5
Rated current I <sub>n</sub> (A)	12	12
<b>Wire data</b>		
Length to strip (mm)	7	7

**INFORMATION.** In cases of micro-surges or total loss of mains power, this module guarantees stable and maintained 24 V DC while the motors are being stopped. This is an absolute must in order to comply with the CE requirement for the machine.

## Module power-up

1. For the XPS-25 and XPS-65 power supplies:

Apply power to the Auxiliary Power Supply from mains through pins 2 and 3 of connector X3; These will power the control circuits of the power supply and provide 24 V DC at connectors X4, X5 and X6.

2. The power supply checks the system status:

### If the status is correct:

The **System OK** contact closes (pins 6 and 7) and it stays closed while the control circuits are powered and no error comes up in any of the modules of the system.

The red FAULT indicator light blinks (it is not indicating an error because there are no phases yet).

### If the status is not correct:

The red FAULT indicator light is permanently on (not blinking).

3. Apply power to the power supply:

Power is applied from mains through the power connectors on top of the power supply.

The soft start begins.

The red FAULT indicator light turns off.

4. green DC BUS ON light on:

After 4 seconds, the green DC BUS ON indicator light turns on meaning that the power bus has the proper dc voltage.

If for any reason an error is activated at the power supply module or at any drive module it supplies to, the system will act as follows:

1. The green indicator light DC BUS ON will turn off indicating that the power supply will stop supplying voltage to the power bus.



**DANGER.** When the DC BUS ON led turns off it may take about 4 minutes for the bus to discharge to a safe value (< 42 V DC) depending on the number of drive modules that are connected.

2. The red FAULT light will be on permanently.

With the Error RESET input (pin 1), it is possible to eliminate the errors at the drives that are part of the system - see chapter 14, resettable errors, of the "man\_dds\_soft.pdf" manual - and it acts as follows:

- Its state will be 0 V DC. Activating it with 24 V DC erases all the errors stored in the memory of each drive of the system.
- Should the cause of the error persist, the corresponding module will show the same error again and it will be necessary to turn the unit back on to eliminate the error if it is a serious error.

The System Speed Enable input (pin 5) is related to the Speed Enable inputs of the drive modules so the System Speed Enable activates/cancels internally all the Speed Enable of the drives connected to the power supply through the internal bus.

- The state of the System Speed Enable is usually 24 V DC.
- When removing the 24 V DC from the System Speed Enable pin is set to 0 V DC, all the drive modules joined together by the same internal bus will brake the motors that they control with the torque corresponding to the active acceleration ramp and when stopped or when reaching the time limit to stop, programmable according to parameter GP3 (see chapter 13 of the "man\_dds\_soft.pdf" manual), it cancels the motor torque.

The consumption of each input is between 4.5 and 7 mA.

# 2.

**POWER SUPPLIES**  
Regenerative power supplies

**FAGOR** 

**DDS  
HARDWARE**

**Ref.1310**

## 2.3 Regenerative regulated power supplies

When referring to regenerative regulated (step-up or boost) power supplies, we'll use RPS-80, RPS-75, RPS-45 and RPS-20. They all admit a mains voltage between 400-10% V AC and 460+10% V AC (with a mains frequency of 50/60Hz) and can consume and return to mains sinusoidal DC power with a maximum power factor close to 1. Unlike XPS regenerative power supplies, their bus voltage is programmable and independent from the mains voltage; i.e. for the same power absorbed, the bus voltage of the RPS can be higher than the that of the XPS.

These power supplies look like this on the outside:

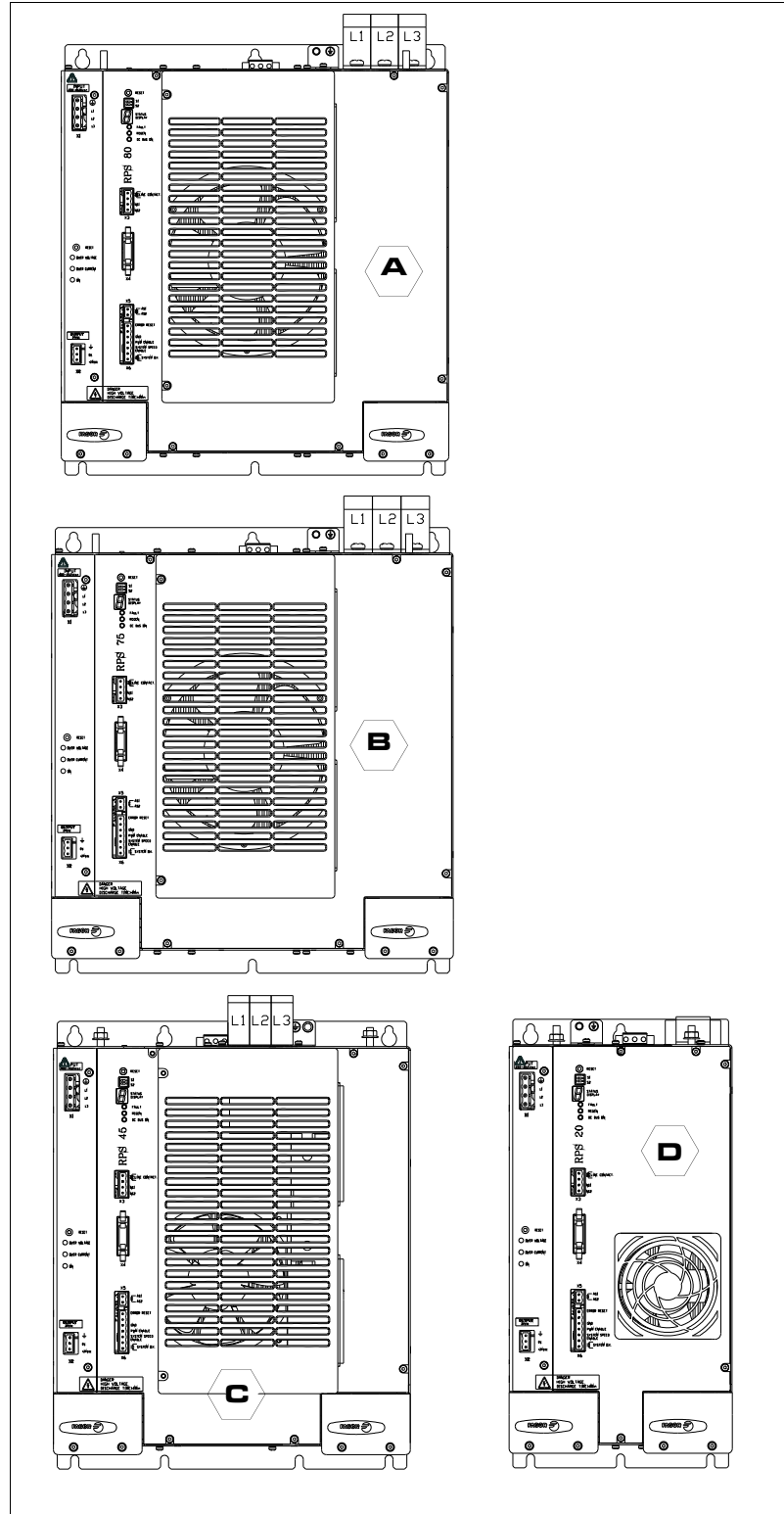

F. H2/26

Regenerative regulated power supplies:

A. RPS-80, B. RPS-75, C. RPS-45, D. RPS-20.

# 2.

**POWER SUPPLIES**  
Regenerative regulated power supplies



DDS  
HARDWARE

Ref.1310

However:

The **RPS-80** supplies 80 kW and can return up to 80 kW to mains for an S1 duty cycle. For an S6-40% duty cycle it supplies 104 kW and can return 104 kW to mains.

The **RPS-75** supplies 75 kW and can return up to 75 kW to mains for an S1 duty cycle. For an S6-40% duty cycle it supplies 97 kW and can return 97 kW to mains.

The **RPS-45** supplies 45 kW and can return up to 45 kW to mains for an S1 duty cycle. For an S6-40% duty cycle it supplies 59 kW and can return 59 kW to mains.

The **RPS-20** supplies 20 kW and can return up to 20 kW to mains for an S1 duty cycle. For an S6-40% duty cycle it supplies 26 kW and can return 26 kW to mains.



**INFORMATION.** They all integrate an auxiliary 24 V DC, 8 A power supply to feed its own control circuits and those of the modular drives connected to them. Consequently, they will not require the auxiliary power supply APS-24 to perform this function unless more than 8 A are required.

#### NOTE PRIOR TO INSTALLATION

Before installing an RPS power supply when using non-FAGOR motors, remember that:

#### MANDATORY.

Any element that will be part of the drive-motor system powered by an RPS must meet the isolation requirements described in EN 61800-5-1.

- All the components connected to the intermediate circuit must run permanently on a voltage higher than 625 V in the intermediate circuit.
- If the motor temperature sensor is a KTY type, it must also meet the requirements described in EN 61800-5-1.

#### RECOMMENDATION.

Configure the RPS power supply with the minimum bus voltage to satisfactorily meet the features required by the system.



# 2.

**POWER SUPPLIES**  
Regenerative regulated power supplies

**FAGOR**

**DDS  
HARDWARE**

**Ref.1310**

**RPS modules**

**Technical data**

**T. H2/23** Technical characteristics of the RPS modules.

	RPS-80	RPS-75	RPS-45	RPS-20
Power supply (Vmains)	Three-phase 50/60 Hz, with a voltage range between 400 -10 % and 460 +10 % V AC			
Rated mains power consumption	80 kW	76 kW	46 kW	21 kW
Min. power cable section <sup>1</sup>	70 mm <sup>2</sup>	70 mm <sup>2</sup>	35 mm <sup>2</sup>	10 mm <sup>2</sup>
Power bus voltage VBUS <b>PROG</b>	600, 625 or 725 V DC. Programmable with VP5			
Max. power bus voltage VBUS <b>MAX</b>	775 V DC			
Rated (peak, in S6) output current <sup>2</sup>	128 A (166.5 A)	120 A (156 A)	72 A (95 A)	32 A (41.6 A)
Rated (peak, in S6) output power <sup>3</sup>	80 kW (104 kW)	75 kW (97 kW)	45 kW (59 kW)	20 kW (26 kW)
Power dissipated at max. load	1 kW	1 kW	0.7 kW	0.5 kW
Related chokes (three-phase)	choke RPS-75-3	choke RPS-75-3	choke RPS-45	choke RPS-20
Choke cable - RPS (shielded) (max. length: 2 m) <sup>1</sup>	70 mm <sup>2</sup>	70 mm <sup>2</sup>	35 mm <sup>2</sup>	10 mm <sup>2</sup>
Power for the module control circuit (24 V DC)	Three-phase 50/60 Hz, with a voltage range between 400 -10 % and 460 +10 % V AC			
Mains consumption to generate 24 V DC	0.7 A			
Output voltage of the auxiliary power	24 V DC ± 5%			
Max. current supplied	8 A at 24 V DC (192 W)			
Filter capacity	2145 µF, 900 V		825 µF, 900 V	560 µF, 900 V
Energy stored in capacitors	0.5 C V <sup>2</sup>			
Max. "SYSTEM OK", "LINE CONTACT" and "AS1-AS2" contact voltage	125 V AC, 150 V DC			
Max. current at contacts "SYSTEM OK", "LINE CONTACT" and "AS1-AS2"	2 A			
Status display	7-segments display			
Width (mm/inches)	350 / 13.8	350 / 13.8	311 / 12.2	194 / 7.6
Approx. mass (kg/lb)	20 / 44.1	20 / 44.1	16 / 35.3	10 / 22.0

<sup>1</sup> Depending on the rated operating power.

<sup>2</sup> For a bus voltage of 625 V.

<sup>3</sup> See derating curves in case of high temperatures.

**T. H2/24** Ambient conditions and other characteristics of the RPS modules.

	RPS-80	RPS-75	RPS-45	RPS-20
Ambient temperature <sup>3</sup>	5 °C / 45 °C (41 °F / 113 °F)			
Storage temperature	- 20 °C / 60 °C (- 4 °F / 140 °F)			
Max. humidity	< 90 % (non condensing at 45 °C / 113 °F)			
Max. altitude without loss of features	1000 m (3281 ft) above sea level			
Operating vibration	0.5 G			
Shipping vibration	2 G			
Sealing	IP 20			

<sup>3</sup> See derating curves in case of high temperatures.

**2.**

POWER SUPPLIES  
Regenerative regulated power supplies



DDS  
HARDWARE

Ref.1310

Power diagram

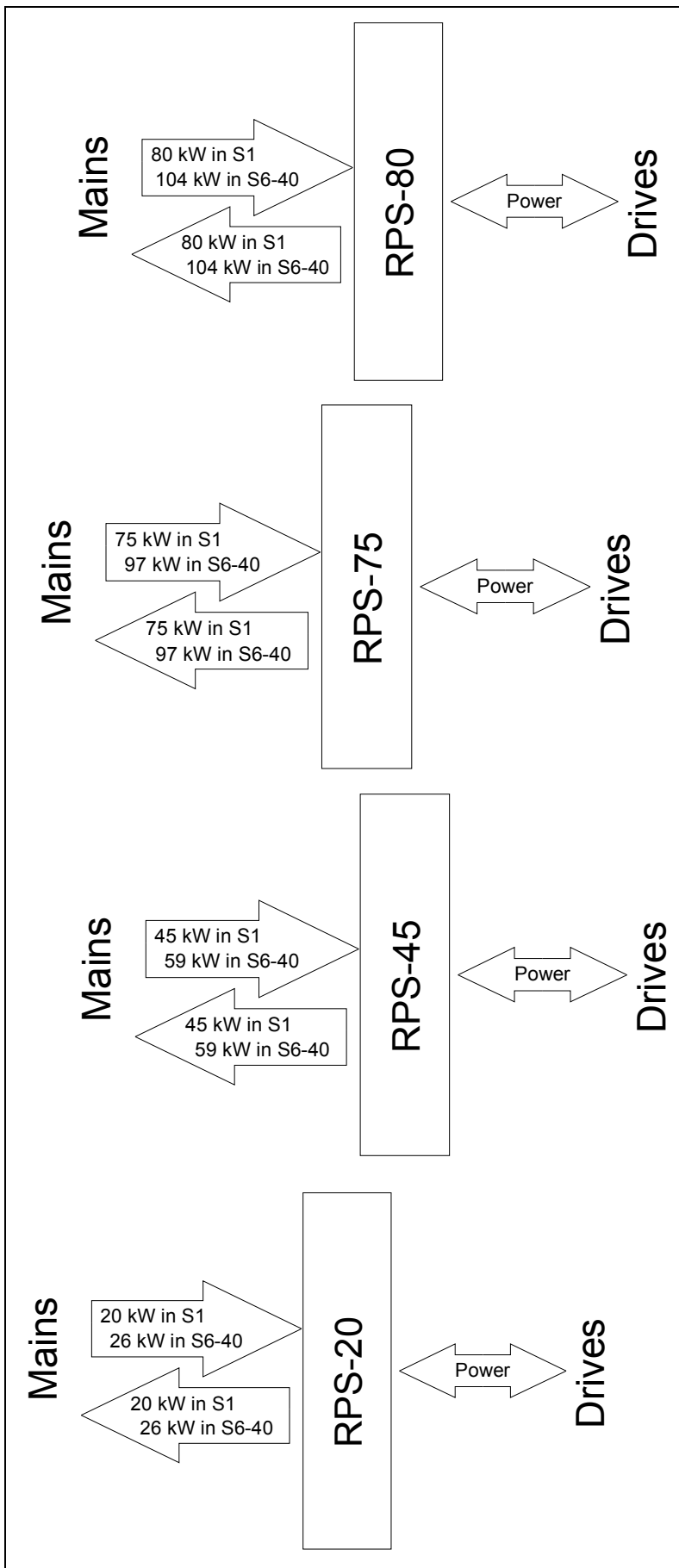

F. H2/27  
Power diagram.



**POWER SUPPLIES**  
Regenerative regulated power supplies



DDS  
HARDWARE

Ref.1310

# 2.

POWER SUPPLIES  
Regenerative regulated power supplies

## Power derating

The following graph shows the maximum rms current in continuous S1 ( $P_n$ ) and intermittent S6-40% ( $P_{S6}$ ) duty cycles for a switching frequency of the power transistors of 8 kHz in a temperature range between 5 °C (41 °F) and 60 °C (140 °F). See the load cycles in the next section.

### Power derating graph / RPS-80

T. H2/25 Power derating on RPS-80 power supply (8 kHz).

Tamb		Pn (power in S1)	PS6 (power in S6-40%)
in °C	in °F	in kW	in kW
35	95	80.0	104.0
40	104	80.0	104.0
45	113	80.0	104.0
50	122	76.6	99.5
55	131	72.0	93.6
60	140	67.3	87.5

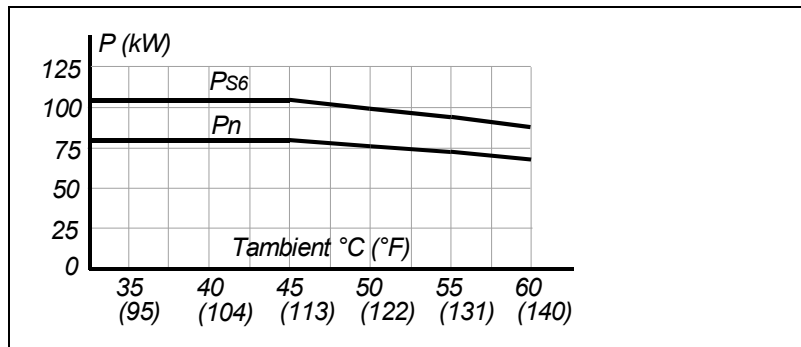

### F. H2/28

Power derating on RPS-80 power supply for  $f_c = 8$  kHz.

### Power derating graph / RPS-75

T. H2/26 Power derating on RPS-75 power supply (8 kHz).

Tamb		Pn (power in S1)	PS6 (power in S6-40%)
in °C	in °F	in kW	in kW
35	95	75.0	97.5
40	104	75.0	97.5
45	113	75.0	97.5
50	122	71.1	92.5
55	131	67.1	87.2
60	140	63.0	81.9

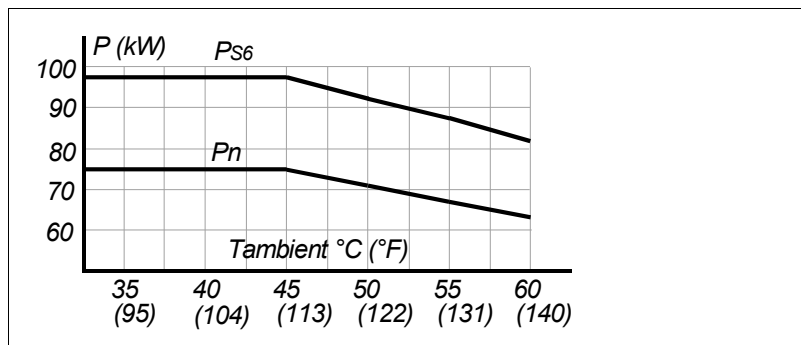

### F. H2/29

Power derating on RPS-75 power supply for  $f_c = 8$  kHz.



DDS  
HARDWARE

Ref.1310

**Power derating graph / RPS-45**

**T. H2/27** Power derating on RPS-45 power supply (8 kHz).

Tamb		Pn (power in S1)	PS6 (power in S6-40%)
in °C	in °F	in kW	in kW
35	95	45.4	59.0
40	104	45.4	59.0
45	113	45.4	59.0
50	122	41.4	53.9
55	131	37.4	48.6
60	140	33.2	43.1

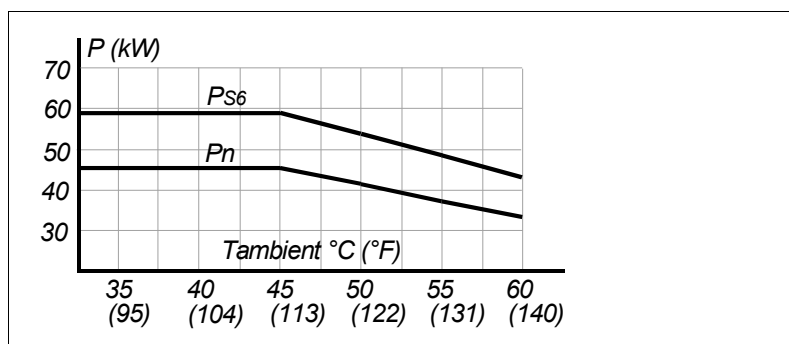

**F. H2/30**

Power derating on RPS-45 power supply for fc = 8 kHz.

**Power derating graph / RPS-20**

**T. H2/28** Power derating on RPS-20 power supply (8 kHz).

Tamb		Pn (power in S1)	PS6 (power in S6-40%)
in °C	in °F	in kW	in kW
35	95	20.4	26.5
40	104	20.4	26.5
45	113	20.4	26.5
50	122	19.4	25.2
55	131	18.0	23.4
60	140	16.6	21.6

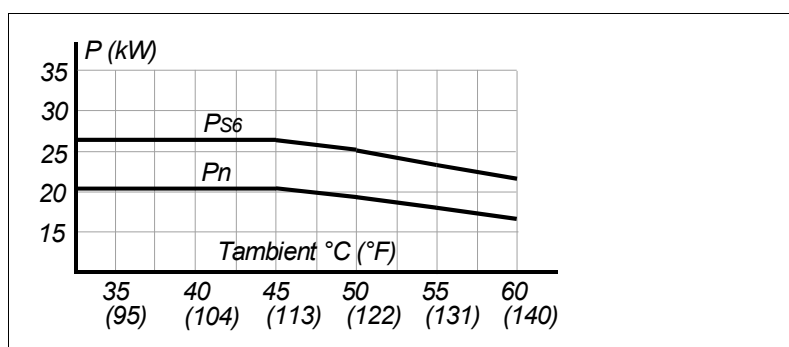

**F. H2/31**

Power derating on RPS-20 power supply for fc = 8 kHz.

**2.**

**POWER SUPPLIES**  
Regenerative regulated power supplies



**DDS  
HARDWARE**

**Ref.1310**

# 2.

POWER SUPPLIES  
Regenerative regulated power supplies

## Operating cycles

### Load cycle S1

**Continuous duty.** Operation with constant load and long enough to achieve thermal balance.

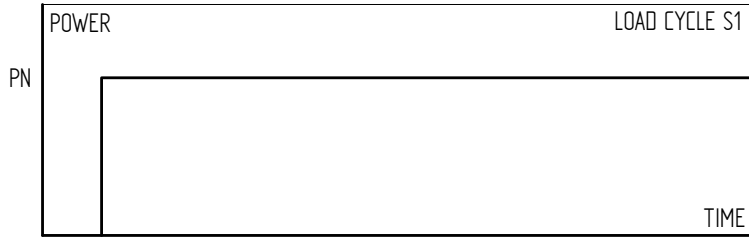

#### F. H2/32

Load cycle S1.

### Load cycle S6-40%

**Periodic uninterrupted duty cycle with intermittent load.** Succession of identical duty cycles, each with a running period under constant load and another period without load. There is no rest period. The 40% running factor indicates that for a 10 minute cycle, it works at constant power for 4 minutes  $P_{S6-40}$  and without load for 6 minutes ( $0.4 \times$  rated current  $P_n$ ).

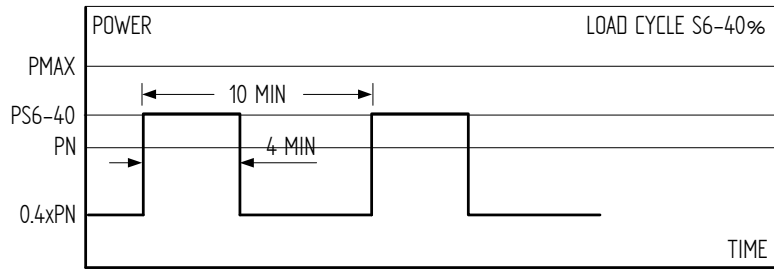

#### F. H2/33

Load cycle S6-40%.

### Cycle at Pmax without previous load

**Periodic intermittent duty.** Succession of identical duty cycles, each with a rest period. The 40% running factor means that for a 10 minute cycle, it works at  $1.6 \times P_n$  for 4 minutes and it rests (no power) for 6 minutes.

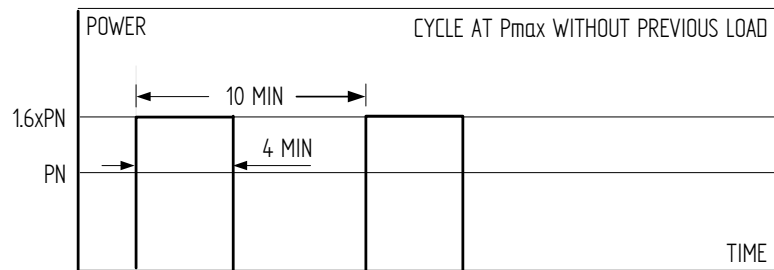

#### F. H2/34

Cycle at  $P_{max}$  without previous load.



DDS  
HARDWARE

Ref.1310

**Block diagram**

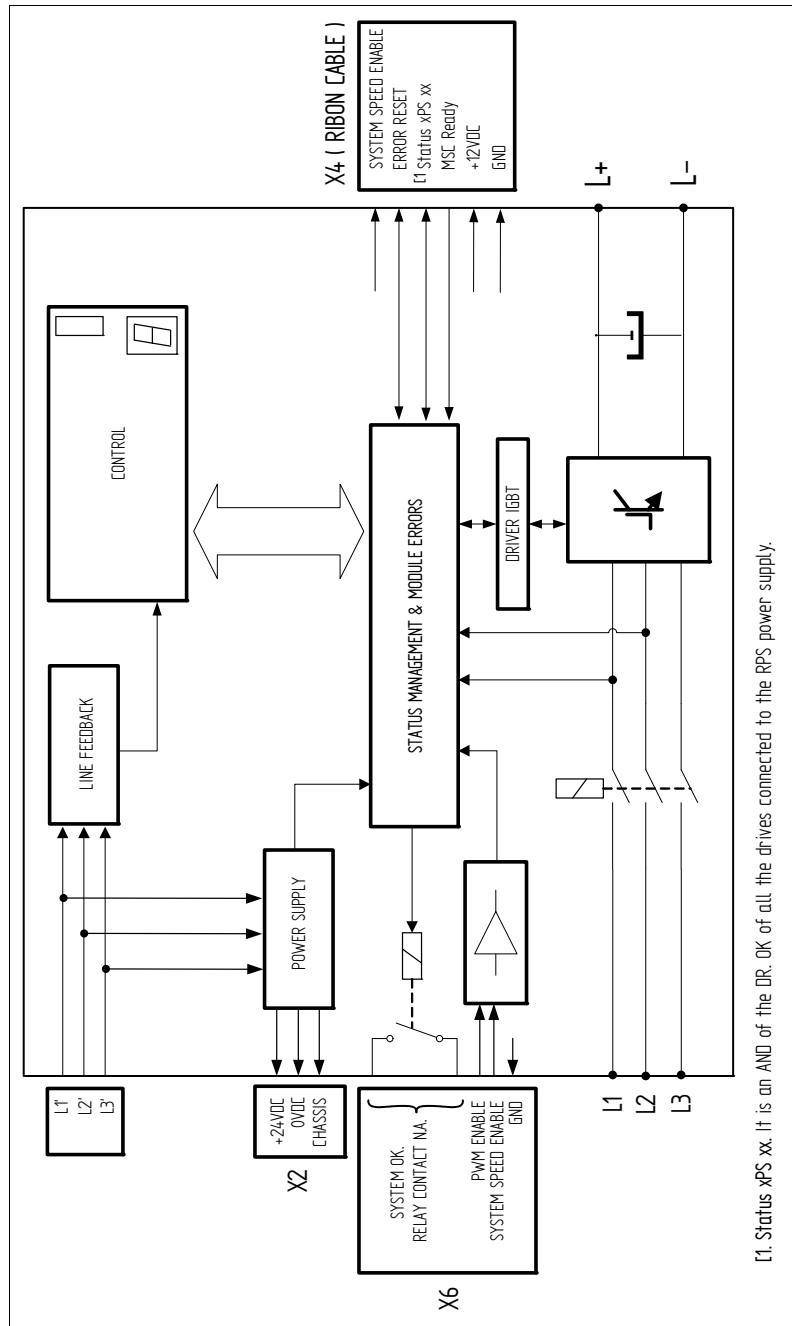

**F. H2/35**

Block diagram.

**2.**

**POWER SUPPLIES**  
Regenerative regulated power supplies



**DDS  
HARDWARE**

**Ref.1310**

**RPS-80. Connector description**

The following figure shows the regenerative regulated power supply RPS-80 and its connector layout:

**2.**

**POWER SUPPLIES**  
Regenerative regulated power supplies

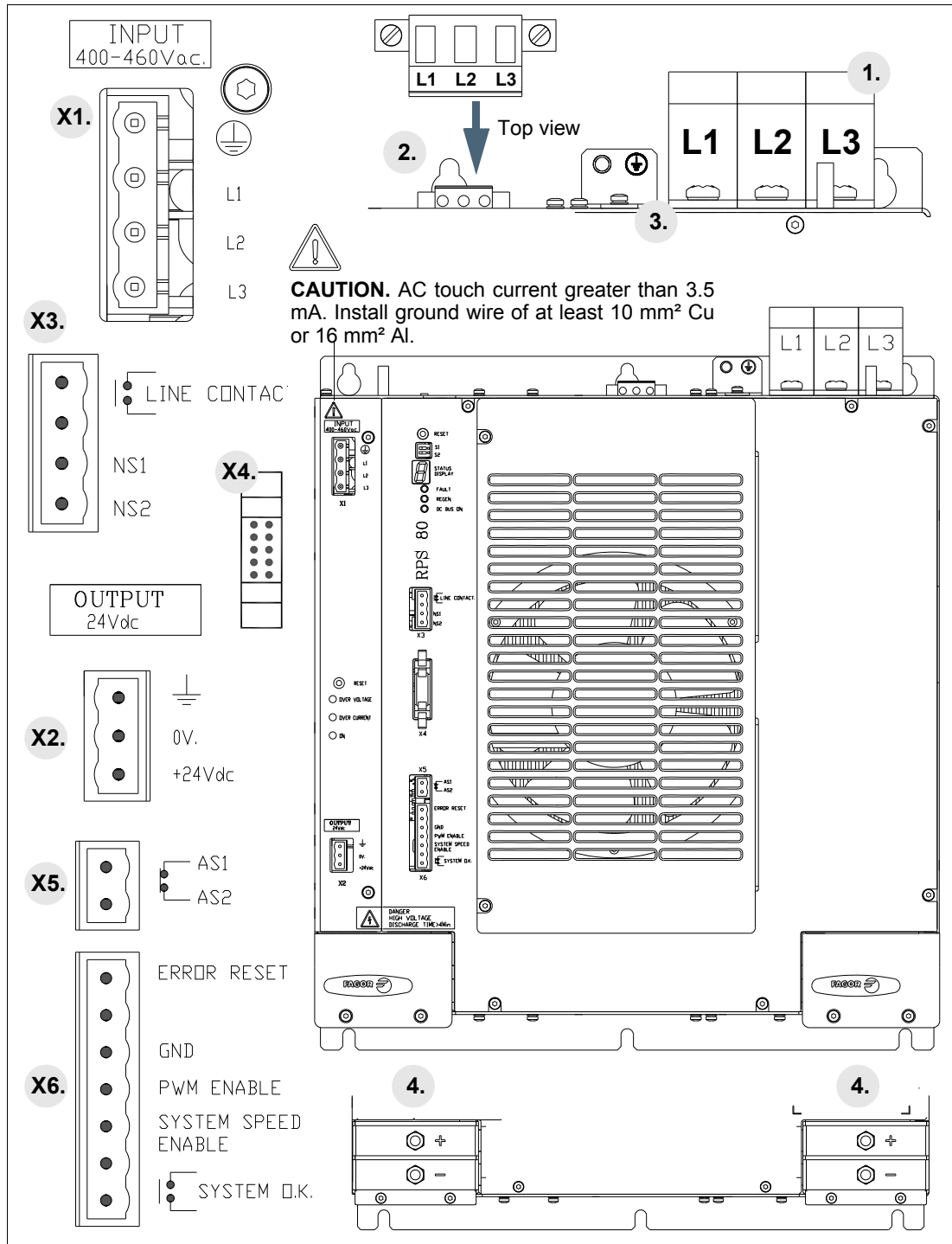

**F. H2/36**

Connectors of the RPS-80 power supply.

1. Power connector for the three-phase mains.
  2. Line input connector for synchronism.
  3. Ground connection for the mains cable.
  4. Power Bus supplying power to the drive modules through metal bars.
- X1. Connector of the integrated auxiliary three-phase power supply.  
 X2. Output connector of the auxiliary 24 V DC power supply integrated into the module.  
 X3. Connector to be used to open/close the main internal contactor (pins NS1 and NS2) and acknowledge externally the status of the contactor (LINE CONTACT pins).  
 X4. Connector to communicate with the modular drives through the internal bus.  
 X5. Connector for the external acknowledgment of the status of the safety relay.  
 X6. Connector for the basic control signals.



DDS  
HARDWARE

Ref.1310

### RPS-75. Connector description

The following figure shows the regenerative regulated power supply RPS-75 and its connector layout:

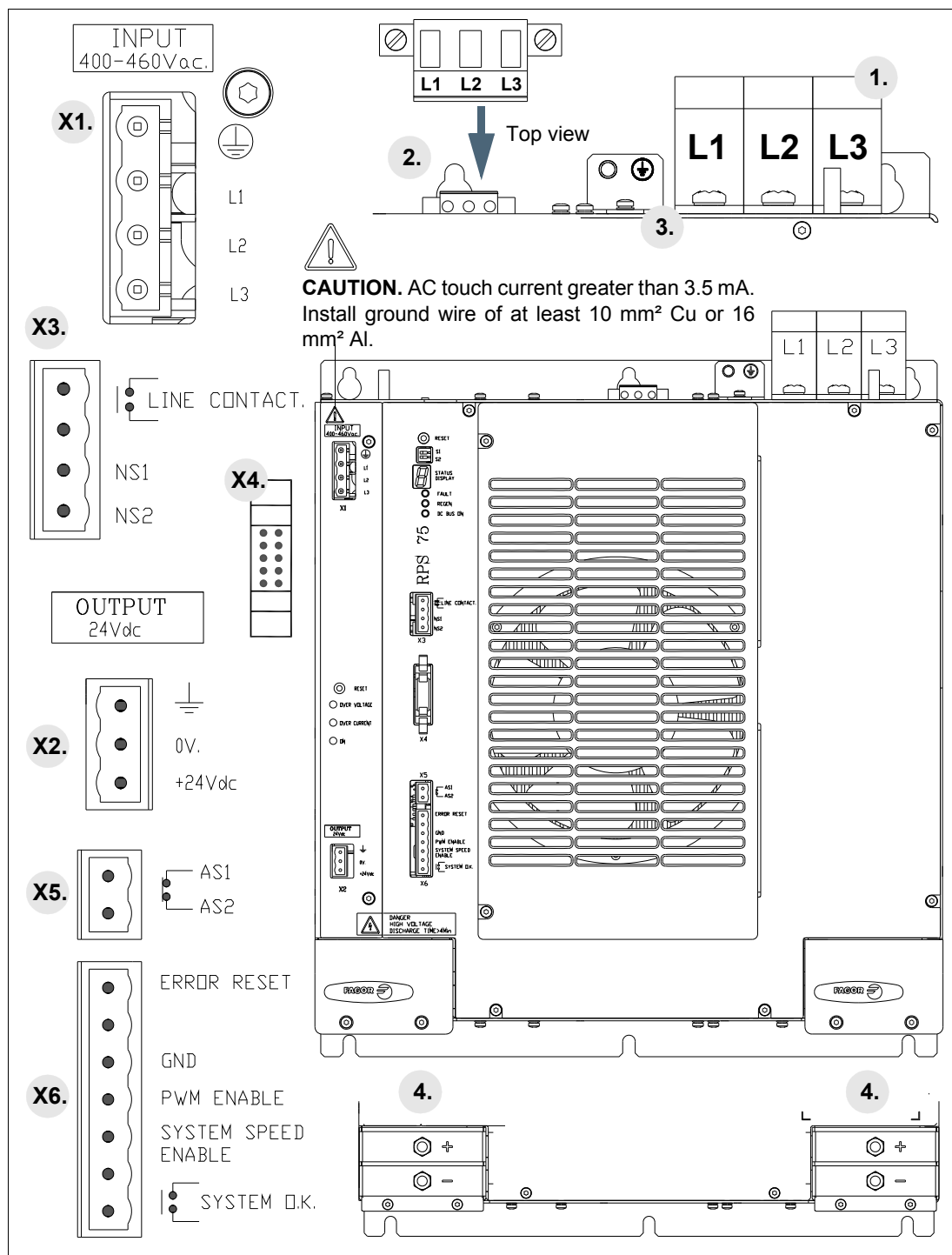

#### F. H2/37

Connectors of the RPS-75 power supply.

1. Power connector for the three-phase mains.
2. Line input connector for synchronism.
3. Ground connection for the mains cable.
4. Power Bus supplying power to the drive modules through metal bars.
- X1. Connector of the integrated auxiliary three-phase power supply.
- X2. Output connector of the auxiliary 24 V DC power supply integrated into the module.
- X3. Connector to be used to open/close the main internal contactor (pins NS1 and NS2) and acknowledge externally the status of the contactor (LINE CONTACT pins).
- X4. Connector to communicate with the modular drives through the internal bus.
- X5. Connector for the external acknowledgment of the status of the safety relay.
- X6. Connector for the basic control signals.

## 2.

**POWER SUPPLIES**  
Regenerative regulated power supplies



**DDS  
HARDWARE**

Ref.1310

**RPS-45. Connector description**

The following figure shows the regenerative regulated power supply RPS-45 and its connector layout:

**2.**

**POWER SUPPLIES**  
Regenerative regulated power supplies

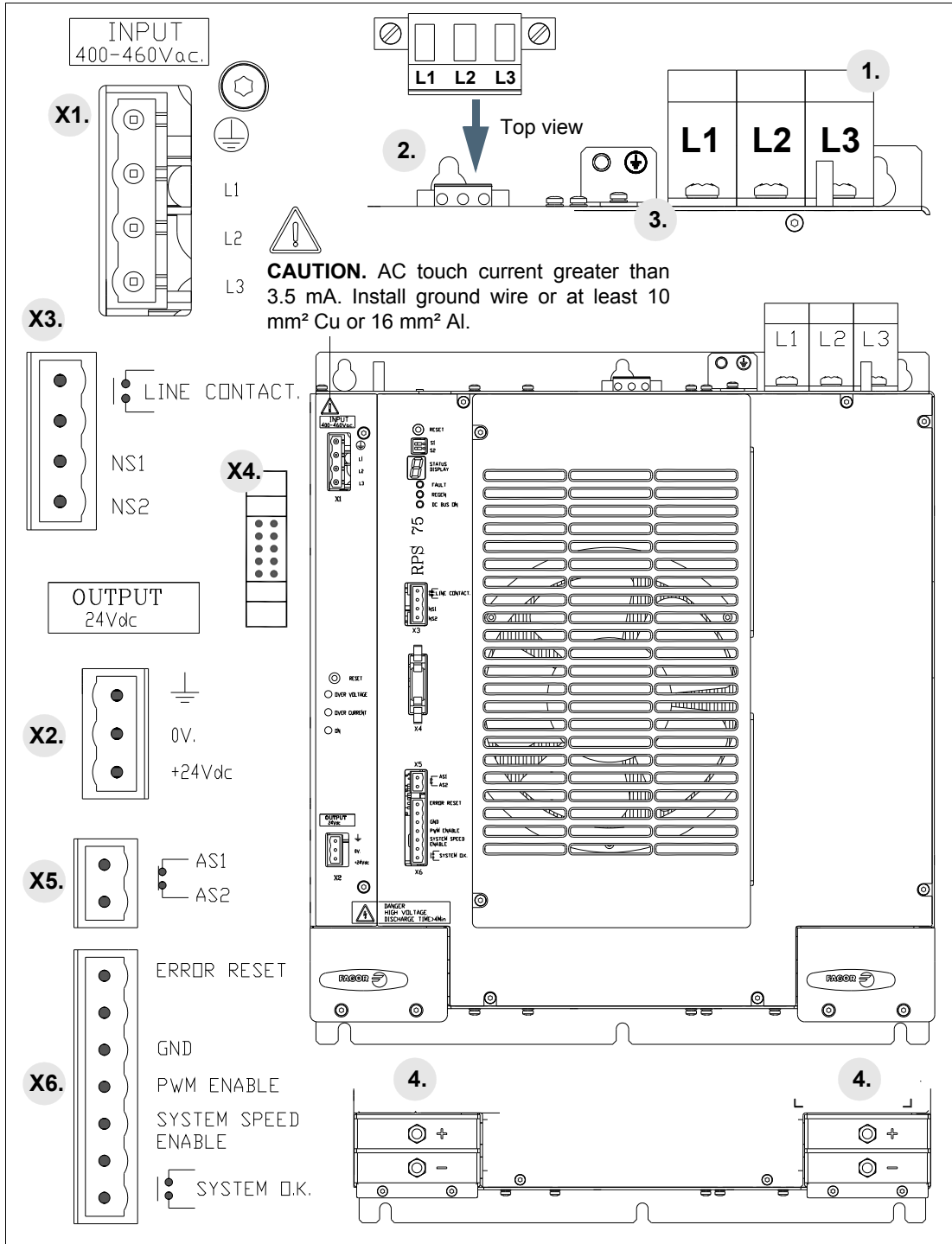

**F. H2/38**

Connectors of the RPS-45 power supply.

1. Power connector for the three-phase mains.
2. Line input connector for synchronism.
3. Ground connection for the mains cable.
4. Power Bus supplying power to the drive modules through metal bars.
- X1. Connector of the integrated auxiliary three-phase power supply.
- X2. Output connector of the auxiliary 24 V DC power supply integrated into the module.
- X3. Connector to be used to open/close the main internal contactor (pins NS1 and NS2) and acknowledge externally the status of the contactor (LINE CONTACT pins).
- X4. Connector to communicate with the modular drives through the internal bus.
- X5. Connector for the external acknowledgment of the status of the safety relay.
- X6. Connector for the basic control signals.



**DDS  
HARDWARE**

**Ref.1310**

### RPS-20. Connector description

The following figure shows the regenerative regulated power supply RPS-20 and its connector layout:

Top view of the connectors

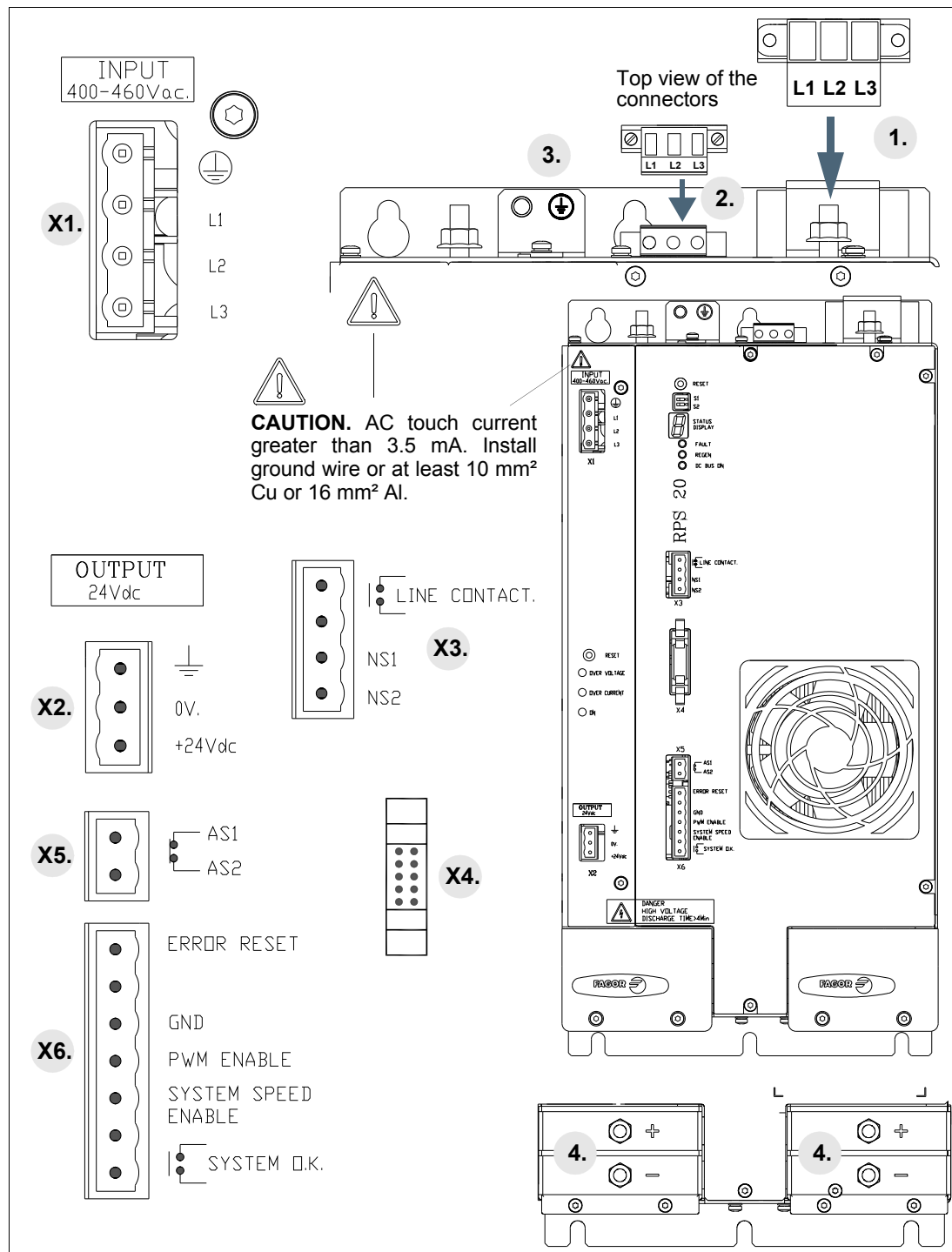

**2.**

**POWER SUPPLIES**  
Regenerative regulated power supplies

#### F. H2/39

Connectors of the RPS-20 power supply.

1. Power connector for the three-phase mains.
2. Line input connector for synchronism.
3. Ground connection for the mains cable.
4. Power Bus supplying power to the drive modules through metal bars.
- X1. Connector of the integrated auxiliary three-phase power supply.
- X2. Output connector of the auxiliary 24 V DC power supply integrated into the module.
- X3. Connector to be used to open/close the main internal contactor (pins NS1 and NS2) and acknowledge externally the status of the contactor (LINE CONTACT pins).
- X4. Connector to communicate with the modular drives through the internal bus.
- X5. Connector for the external acknowledgment of the status of the safety relay.
- X6. Connector for the basic control signals.



**DDS  
HARDWARE**

**Ref.1310**

# 2.

**POWER SUPPLIES**  
Regenerative regulated power supplies

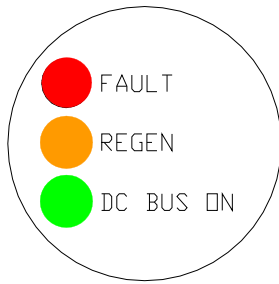

### Lights indicating the status of the main power supply

All the RPS regenerative regulated power supplies has the following lights on the front panel to indicate the status of the main power supply:

- **Blinking FAULT.** Blinking red LED. It indicates that the system is ready waiting for mains to be connected. It indicates, therefore, that there is no error and that there is no mains voltage. 0 state of the operating modes.
- **FAULT turned ON.** Red LED on all the time. It indicates that there is an error either at the power supply or in some module of the DDS system. The error will be shown at the display of the power supply - see the section "status display" later on - as well as at that of the relevant drive. It indicates that the system is not ready (**SYSTEM OK** open). 4 state of the operating modes.

**NOTE.** If the red LED is always on and the display of the power supply shows a 0 with a blinking point, - see the section "status display" later on -, the error has been originated in some module of the system, not at the RPS power supply.

- **FAULT turned OFF.** Red LED off. It indicates that the system is charging the DC BUS. It indicates, therefore, that there is no error and that the mains phases are on. 1 state of the operating modes.
- **REGEN.** Amber LED on. It indicates that the module is working in energy regenerating (returning to mains) mode. (3 state of the operating modes).
- **DC BUS ON.** Green LED on. It indicates that the DC BUS is fully charged and the module offers all its power at the bus. States 2 and 3 of the operating modes.

### Lights indicating the status of the auxiliary power supply

RPS regenerative power supplies have a reset button and the following lights on the front panel to indicate the status of the integrated auxiliary power supply:

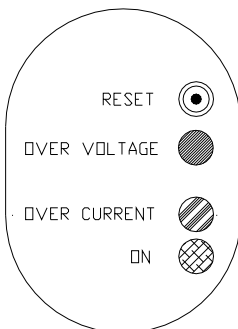

- **RESET.** Initializes the auxiliary 24 V DC power supply.
- **OVER VOLTAGE.** It indicates an error due to over-voltage at the 24 V DC output or due to over-temperature.
- **OVER CURRENT.** It indicates an over-current error at the 24 V DC output.
- **ON.** It indicates that there are 24 V DC at the output when is turned on.



DDS  
HARDWARE

Ref.1310

## Other elements

Besides the various connectors, the front panel of these power supplies has other elements that are mentioned next.

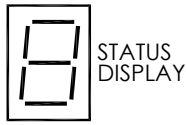

### Status display

The 7-segment status display shows the system start-up sequence as well as the possible errors and warnings that could come up. For further detail, see the section “turning the module on” at the end of this chapter and go to chapter **14. ERROR CODES AND MESSAGES** at the RPS power supplies in the “man\_dds\_soft.pdf” manual to interpret the errors and/or warnings displayed.

### DC BUS command voltage selector switches

The two dip-switches located on top of the status display may be used to program the DC BUS voltage to a particular value. The possible combinations are:

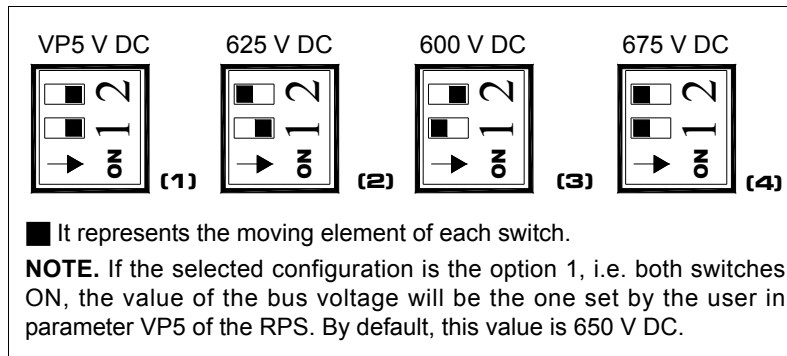
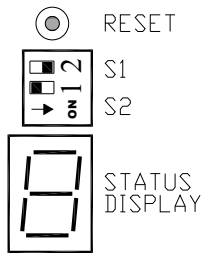

### F. H2/40

Bus voltage selector switches.

#### Example.

Let's suppose that the mains voltage is 460 V AC. The voltage that the DC BUS can supply is  $1.41 \times 460 = 650$  V DC. Therefore, we must select a switch setting like figure **F. H2/40** (option 4), because any of the other settings generates a BUS voltage lower than 650 V DC and the purpose is to be able to raise the BUS voltage higher than the one mains can provide. See the note below for switch configuration (option 1).

If the mains voltage is 430 V AC. The voltage that the DC BUS can supply is  $1.41 \times 430 = 608$  V DC. Therefore, we must select a switch setting that sets a bus voltage higher than this value; i.e. either the one given by option 2 or the one given by option 4 of figure **F. H2/40**. Any of these two settings would be valid. See the note below for switch configuration (option 1).

#### Clarifying note

In the conclusions drawn from these examples, the configuration (option 1) has been ignored because the bus voltage depends on the value set in parameter VP5. This parameter admits values between 500 V DC and 750 V DC and by default it is assigned a voltage of 650 V DC.

Considering that it has been set to its default value (650 V DC), this switch configuration could also be set in both cases of this example.

For further information on parameter VP5 of the RPS power supplies, contact Fagor Automation S. Coop.

# 2.

POWER SUPPLIES  
Regenerative regulated power supplies

## Power connectors

### Terminal strip for mains connection

This connector may be used to connect the power supply to mains. When connecting the power supply to mains, the phases may be connected in any order RST, RTS, TRS, etc.

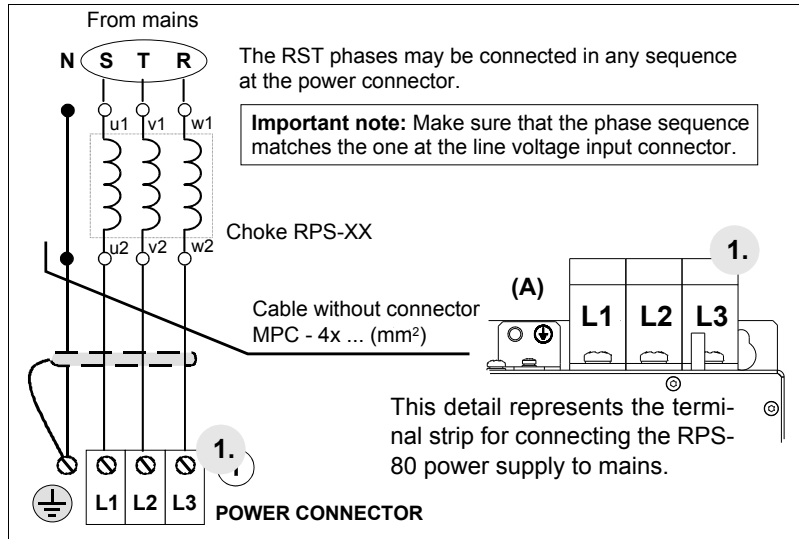

F. H2/41

Terminal strip for connection to mains.

The ground connection of the cable shield is made from the vertical plate (A) next to the terminal strip. See figure F. H2/41.

The following table shows the values for gap, tightening torque, sections and other interesting data of the power feed-through terminal blocks:

T. H2/29 Technical data of the feed-through terminal blocks for mains connection.

Connector data	RPS-80 RPS-75	RPS-45	RPS-20
Gap (mm)	-	-	10.16
Min/max tightening torque (N·m)	15/20	6/8	1.2/1.5
Screw thread	M8	M6	M4
Min./max. section (mm <sup>2</sup> )	35/95	16/50	0.75/10
Rated current I <sub>n</sub> (A)	232	125	41
<b>Wire data</b>			
Length to strip (mm)	27	24	12



**MANDATORY.** As for possible high leak currents, use a protection ground wire with a cross section of at least 10 mm<sup>2</sup> (Cu) or 16mm<sup>2</sup> (Al) or two protection ground wires with the same cross section as that of the wires connected to the power supply terminals. Comply with local regulations on grounding.



**INFORMATION.** IGBT components cannot actually be protected with fuses. Therefore, installing protection fuses when using RPS power supplies does not prevent a failure of the module, but it does minimize the number of components that may be destroyed as a result of a possible failure. **RECOMMENDATION.** Install fast fuses in three-phase power supply lines L1, L2 and L3, for a higher current than the one for S6 of the RPS used. See table T. H6/3.



DDS  
HARDWARE

Ref.1310

### Terminal strip for connecting the mains voltage input

Three-phase line input taken at a point before the three single-phase RPS chokes (one choke per phase). This connection is needed to receive the mains line voltages and it is done through connector (2) as shown in the next figure:

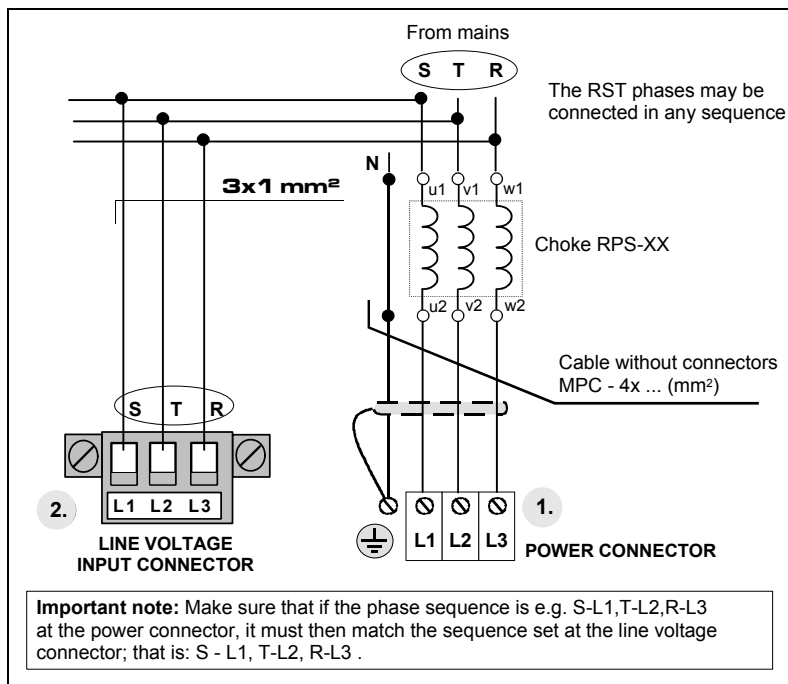

# 2.

**POWER SUPPLIES**  
Regenerative regulated power supplies

#### F. H2/42

Terminal strip for connecting the mains voltage input.

T. H2/30 Data of the pins of the mains voltage sensor connector. See connector 2 of the previous figure.

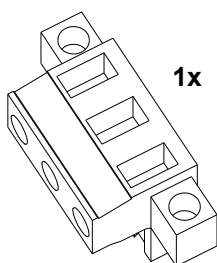

Connector data	RPS-80 RPS-75	RPS-45	RPS-20
Nr of poles	3	3	3
Gap (mm)	7.62	7.62	7.62
Min/max tightening torque (N·m)	0.5/0.6	0.5/0.6	0.5/0.6
Screw thread	M3	M3	M3
Min./max. section (mm <sup>2</sup> )	0.2/2.5	0.2/2.5	0.2/2.5
Rated current I <sub>n</sub> (A)	12	12	12
<b>Wire data</b>			
Length to strip (mm)	7	7	7

The max. current circulating through the wires (screwed into this connector) will be 8.5 mA for a mains voltage of 460 V AC (rms) Therefore, use wires with a minimum section of 1 mm<sup>2</sup>.



**MANDATORY.** The phase order in the line voltage input (2) must be exactly the same as the one selected at the power connector (1). See figure F. H6/2.

For further detail, see chapter 6. **POWER LINE CONNECTION** of this manual.

#### Connection to an external braking resistor (Ballast)

RPS power supplies do not carry a Ballast circuit and, consequently, FAGOR does not have external braking resistors (Ballast) associated with them. In applications requiring a Ballast circuit, one off-the-shelf will have to be installed.



**DDS  
HARDWARE**

**Ref.1310**

# 2.

**POWER SUPPLIES**  
Regenerative regulated power supplies



DDS  
HARDWARE

Ref.1310

## Connection terminals for the power DC bus

At the bottom of the module, at both ends and covered by the screwed-on lid (see figure **F. H2/36**), these power supplies offer the terminals for the power bus (DC BUS) at both ends.



**MANDATORY.** Use the terminals of the power bus located at the end easiest to install the DDS system.

This bus provides a dc voltage output. Set the switches (located on top of the status display) properly to determine its magnitude. The selected bus voltage will stay constant regardless of the mains voltage. See figure **F. H2/40** that shows how to set these switches to select the desired bus voltage.

This voltage set at the power bus can supply all the drive modules that make up the DDS system.



**MANDATORY.** All the modules powered with the same power supply must be connected through the power bus. This condition is a must to run it.



**WARNING.** Never connect the power bus while the system is running . There are voltages of 600 V DC and 725 V DC!

Two plates are supplied with each module to join them with the adjacent drive modules.



**MANDATORY.** The tightening torque of these terminals must be between 2.3 and 2.8 N·m. This point is very important to ensure good electrical contact between modules.

FAGOR power supplies have a soft-start for charging the power bus.

The soft start begins when these two conditions, that are necessary and sufficient, are met:

- No errors at the modules connected through the internal bus (connector X1 at the drives and X4 at the RPS power supplies)
- Presence of the three mains phases at the input of the module.

This startup process begins when the FAULT indicator stops blinking and the status indicator DC BUS ON turns on.



**WARNING.** Before handling these leads, proceed in the following order:

- Stop the motors.
- Disconnect the mains voltage at the electrical cabinet.
- Wait, before handling these leads. The power supply module needs time to decrease the voltage of the power bus down to safe values (< 42 V DC). The green indicator DC BUS ON being turned OFF does not mean that the power bus may be handled or manipulated.
- The discharge time depends on the number of elements connected and it is about 4 minutes.



**WARNING.** The power buses of different power supply modules must never be connected in parallel.



**MANDATORY.** If necessary, the auxiliary power supply APS-24 (24 V DC, 10 A) can only be connected to the DC bus of any regenerative power supply RPS when the version label of the APS-24 (located on top of it) indicates a reference newer than **PF 23A**.



**WARNING.** Never install an APS-24 to the DC bus of a DDS system with a regenerative power supply RPS if the reference of the APS-24 is PF 23A or older.

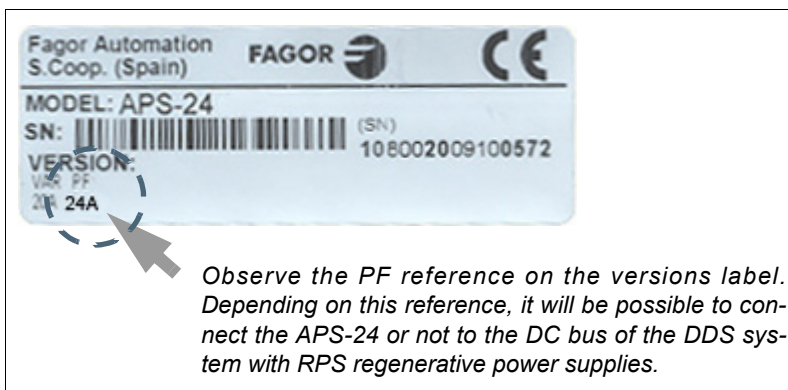

**F. H2/43**

Version label of the APS-24.



**INFORMATION.** It will not be necessary to install external protection fuses in these power lines of the auxiliary power supply. They are already integrated in the power supply itself.

Remember that the purpose of connecting an auxiliary power supply APS-24 to the DC bus of a DDS system is to ensure the supply to all the control circuits of the power supply and of the drive modules connected to the DC bus in case of a mains power outage in the auxiliary power supply ensuring a controlled stop of the moving axes instead of braking out of control by friction.

Bear in mind that although RPS power supplies come with an internal auxiliary power supply offering 3 outputs with 24 V DC and a total of 8 A, 192 W, this power may not be enough to feed the control circuits of all the modules connected or other elements (e.g. a fan). That is why it may be necessary to also install an APS-24 auxiliary power supply to guarantee all the power needed.

The APS-24 auxiliary power supply offers 3 outputs with 24 V DC and a total of 10A, 240 W.

For further information about the auxiliary module APS-24, see chapter 4. **AUXILIARY MODULES** in this manual.

**Connection of the chokes**



**INFORMATION.** RPS regenerative regulated power supplies, unlike XPS, regenerative power supplies do not have connection terminals called CH1 and CH2 at the bottom of the module for connecting the chokes.

These chokes called choke RPS are connected in series with each phase of the three-phase line between the MAINS FILTER □□A and the RPS power supply module. The following table shows the choke associated with the power supply:

Power supply	RPS-80 / RPS-75	RPS-45	RPS-20
3-phase choke	Choke RPS-75-3	Choke RPS-45	Choke RPS-20

For further detail, see chapter 6. **POWER LINE CONNECTION** and chapter 8. **INSTALLATION** in this manual.



**MANDATORY.** Chokes are a must to limit the current circulating from the power bus to mains.

**2.**

**POWER SUPPLIES**  
Regenerative regulated power supplies



**DDS  
HARDWARE**

**Ref.1310**



**WARNING.** Chokes are a must for the operation of a regenerative power supply. Installing a choke with an inductance other than the one recommended for a choke may cause severe damage to the unit.

FAGOR supplies the right CHOKE RPS for this application. See the relevant cable section in table **T. H2/23**. Note that the cable must be shielded.

The data for the RPS choke connection terminals is:

**T. H2/31** Data of the RPS choke connection terminals.

CHOKES	RPS-75-3	RPS-45	RPS-20
Gap (mm)	-	-	10.16
Min/max tightening torque (N·m)	15/20	6	1.5
Section (mm <sup>2</sup> )	70	35	10

## 2.

**POWER SUPPLIES**  
Regenerative regulated power supplies



DDS  
HARDWARE

Ref.1310

## Other connectors

### X1 and X2 connectors

These connectors belong to the auxiliary power supply integrated into the main RPS power supply. This auxiliary power supply is fed through connector X1.

This electrical power is received from the three-phase line to the power supply connected to a point before the power connection operation (before power contactor - **KM1**). It admits a voltage between 400 and 460 V AC.

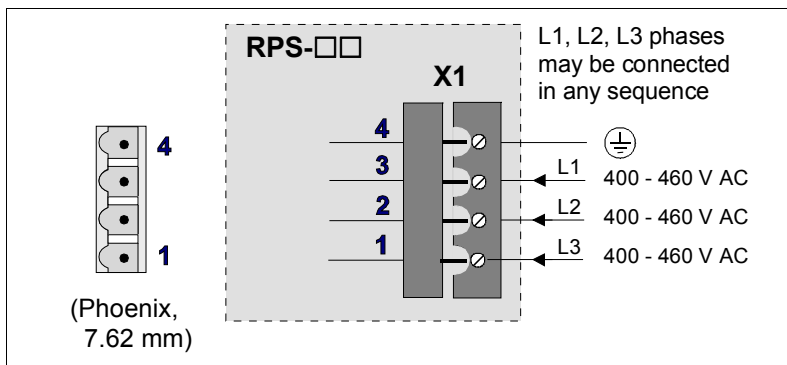

#### F. H2/44

Connector X1. Powering the auxiliary power supply integrated into RPS power supplies.



**INFORMATION.** The mains phases feeding terminals 1, 2 and 3 of connector X1 may be connected in any phase order; i.e. RST, RTS, STR, ...

The following table shows the values for gap, tightening torque, sections of the screws and other data of the plug-in connector for X1.

#### T. H2/32 Data of the plug-in connector for X1.

Connector data	RPS-80 RPS-75	RPS-45 RPS-20
Nr of poles	4	4
Gap (mm)	7.62	7.62
Min/max tightening torque (N·m)	0.5/0.6	0.5/0.6
Screw thread	M3	M3
Min./max. section (mm <sup>2</sup> )	0.2/2.5	0.2/2.5
Rated current I <sub>n</sub> (A)	12	12
<b>Wire data</b>		
Length to strip (mm)	7	7

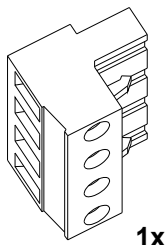

At the same time, pin 1 of connector X2 outputs 24 V DC, 8 A to feed the control circuits of the module itself and of the modular drives connected to the bus.

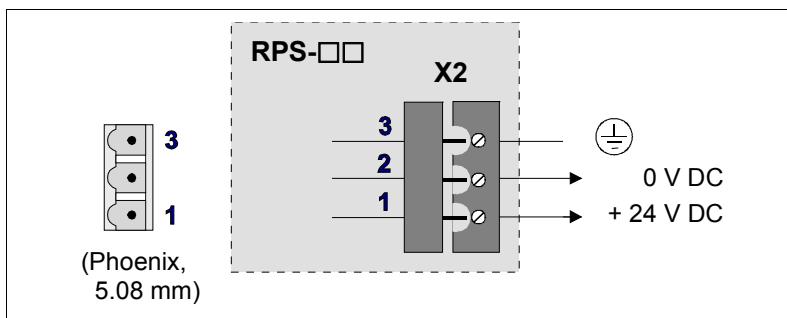

#### F. H2/45

Connector X2. 24 V DC output.

2.

POWER SUPPLIES  
Regenerative regulated power supplies



DDS  
HARDWARE

Ref.1310

**2.**

**POWER SUPPLIES**  
Regenerative regulated power supplies

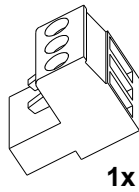

The following table shows the values for gap, tightening torque, sections of the screws and other data of the plug-in connector for X2.

**T. H2/33** Data of the plug-in connector for X2.

Connector data	RPS-80 RPS-75	RPS-45 RPS-20
Nr of poles	3	3
Gap (mm)	5.00	5.00
Min./max. tightening torque (N·m)	0.5/0.6	0.5/0.6
Screw thread	M3	M3
Min./max. section (mm <sup>2</sup> )	0.2/2.5	0.2/2.5
Rated current I <sub>n</sub> (A)	12	12
<b>Wire data</b>		
Length to strip (mm)	7	7

**INFORMATION.** In cases of micro-surges or total loss of mains power, this module guarantees stable and maintained 24 V DC while the motors are being stopped. This is an absolute must in order to comply with the CE requirement for the machine.

**Example regarding the 24 V DC of connector X2**

A door closes an enclosure that contains a DDS system with an RPS power supply. The 24 V DC supplied at pin 1 of connector X2 may be taken to one end of the door opening/closing switch and connect the other end to pin 4 <PWM ENABLE> of control connector X6. When the door is closed, 24 V DC are applied to pin 4 <PWM ENABLE> hence letting the system run. When the door opens, the switch opens and voltage is no longer applied to pin 4 of X6 hence opening the integrated safety relay. The system stops.

**NOTE.** Do not take this example as a real application, but just as an approach to the functionality of the **PWM ENABLE**.

**X3 connector**

The main integrated contactor "LINE CONTACT" (N.O., **N**ormally **O**pen) is closed through connector X3.



**MANDATORY.** Pins 3 and 4 **MUST BE** short-circuited to close the internal contactor of the power supply and let the system run. Hence, get a 1 mm<sup>2</sup> cable and jumper NS1 (pin 3) and NS2 (pin 4) externally to close the main internal contactor. Remember that these pins do not come short-circuited from the factory and if they are not short-circuited by the user, the DC bus will not be charged.

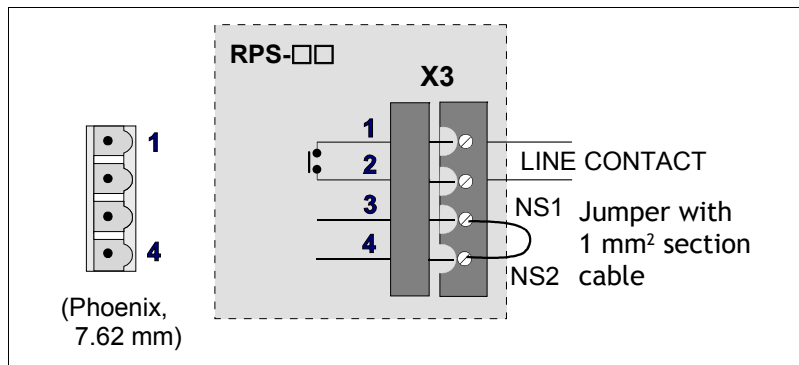

**F. H2/46**

Connector X3. Closing the main internal contactor "LINE CONTACT".

The status of the contactor will be acknowledged through pins 1 and 2 of this connector and the CNC, PLC, control panel, etc. will confirm that the integrated contactor has actually closed.



DDS  
HARDWARE

Ref.1310

**NOTE.** It is important to know that if NS1 (pin 3 de X3) and NS2 (pin 4 de X3) are not short-circuited by the user, the main internal contactor “LINE CONTACT” will stay open. The power supply will start up, but the DC BUS will not charge and, therefore, the axes cannot move. The status display may show the warning - **A315** - indicating that the DC bus charging time (SoftStart type) has exceeded the maximum set value because it never gets charged. **Therefore, the main internal contactor “LINE CONTACT” (pins 3 and 4) MUST BE CLOSED for the system to run.**

The following table shows the values for gap, tightening torque, sections of the screws and other data of the plug-in connector for X3.

**T. H2/34** Data of the plug-in connector for X3.

Connector data	RPS-80 RPS-75	RPS-45 RPS-20
Nr of poles	4	4
Gap (mm)	5.00	5.00
Min/max tightening torque (N·m)	0.5/0.6	0.5/0.6
Screw thread	M3	M3
Min./max. section (mm <sup>2</sup> )	0.2/2.5	0.2/2.5
Rated current I <sub>n</sub> (A)	12	12
<b>Wire data</b>		
Length to strip (mm)	7	7

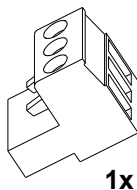

**X4 connector**

This connector may be used to connect the various modules to each other through the internal bus communicating with each other the power supply and all the servo drives that make up the DDS system.

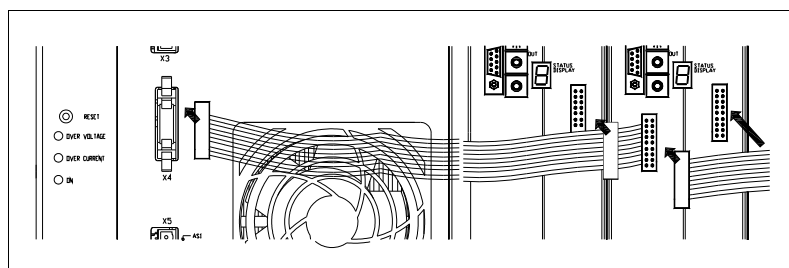

**F. H2/47**

Connector X4. Internal bus connection between modules.

A ribbon cable is provided with each module (power supply or drive) for this connection.

**X5 connector**

This connector X5 of the RPS power supply is associated with the second contact (N.C., **Normally Closed**) of an internal safety relay (with guided contacts). The status of the relay (initially closed) will be acknowledged through its two pins and a CNC, PLC, control panel, etc. will confirm that the integrated safety relay has actually opened or closed. These two terminals are identified as AS1 and AS2. The opening or closing of this relay depends on whether 24 V DC are present at pin 4 <PWM ENABLE> of control connector X6.

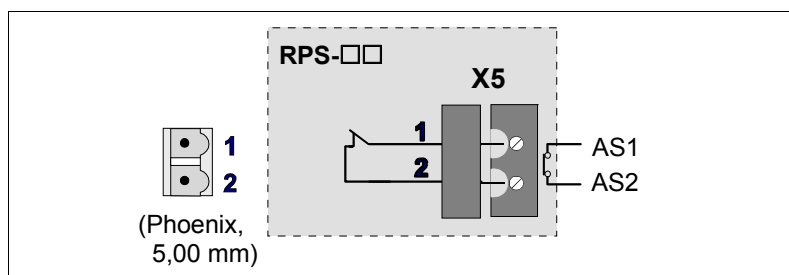

**F. H2/48**

Connector X5. External acknowledgment of the status of the integrated safety relay.

**2.**

**POWER SUPPLIES**  
Regenerative regulated power supplies



**DDS  
HARDWARE**

**Ref.1310**

**2.**

**POWER SUPPLIES**  
Regenerative regulated power supplies

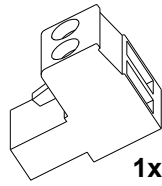

The following table shows the values for gap, tightening torque, sections of the screws and other data of the plug-in connector for X5.

**T. H2/35** Data of the plug-in connector for X5.

Connector data	RPS-80 RPS-75	RPS-45 RPS-20
Nr of poles	2	2
Gap (mm)	5.00	5.00
Min/max tightening torque (N·m)	0.5/0.6	0.5/0.6
Screw thread	M3	M3
Min./max. section (mm <sup>2</sup> )	0.2/2.5	0.2/2.5
Rated current I <sub>n</sub> (A)	12	12
<b>Wire data</b>		
Length to strip (mm)	7	7

**X6 connector**

The screwed-on 7-pin Phoenix connector with screw (5.00 pitch) that the RPS power supply has on its face plate for controlling the module.

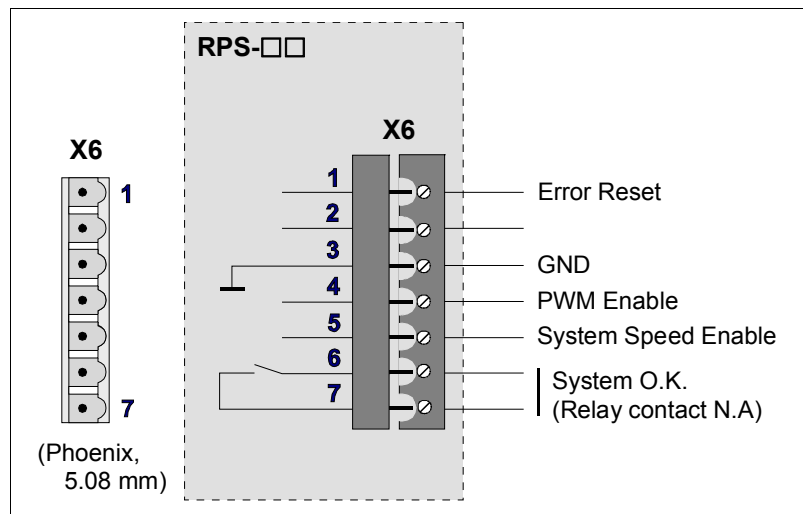

**F. H2/49**

Connector X6. Control.

A 1.25 A fuse protects the internal circuits.

**NOTE.** Remember that the internal circuits of PS-65A non-regenerative power supplies must be powered by an auxiliary 24 V DC power supply, “APS-24”; that’s why its control connector has three terminals more than connector X6 of the RPS.

The following table shows the values for gap, tightening torque, sections of the screws and other data of the plug-in connector for X6.

**T. H2/36** Data of the plug-in connector for X6.

Connector data	RPS-80 RPS-75	RPS-45 RPS-20
Nr of poles	7	7
Gap (mm)	5.00	5.00
Min/max tightening torque (N·m)	0.5/0.6	0.5/0.6
Screw thread	M3	M3
Min./max. section (mm <sup>2</sup> )	0.2/2.5	0.2/2.5
Rated current I <sub>n</sub> (A)	12	12
<b>Wire data</b>		
Length to strip (mm)	7	7

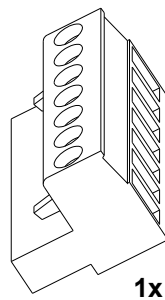

**DDS  
HARDWARE**

**Ref.1310**

The next table shows the signals and other considerations related to each pin of connector X6:

**T. H2/37** Description of the pins of connector X6.

1	ERROR RESET	System error RESET input (24 V DC; 4.5-7 mA).
2	N.C.	Not connected
3	GND	0 volts reference for digital inputs. Error RESET (1) and System Speed Enable (5).
4	PWM ENABLE	Safety. Power bus voltage enable input (24 V DC).
5	SYSTEM SPEED ENABLE	General system speed enable. (24 V DC; 4.5-7 mA).
6	SYSTEM OK	Contact indicating module status. It opens in case of failure. Limit 1 A at 24 V.
7	SYSTEM OK	

# 2.

**POWER SUPPLIES**  
Regenerative regulated power supplies

**FAGOR** 

**DDS  
HARDWARE**

**Ref.1310**

# 2.

POWER SUPPLIES  
Regenerative regulated power supplies

## Module power-up

When turning on the RPS power supply module or doing a reset, various messages appear on its seven-segment display:

- Software version, after the r with the identifying digits.
- Error listing.

Stages shown on the 7-segment display:

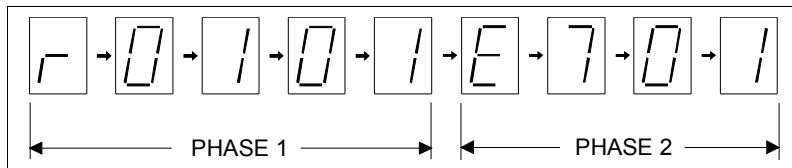

### F. H2/50

Module startup stages.

- Software version displaying stage: It shows the software version loaded in the module. It first shows the letter r (indicating the version <release>), followed by the version number (digit by digit) <sup>(A)</sup>. When the drive is active and the axis is being governed, the display will show the zero digit with a blinking dot <sup>(B)</sup>.

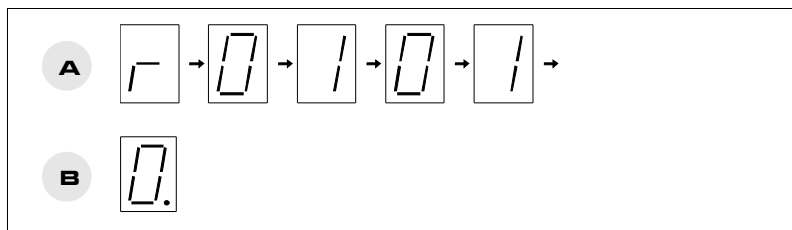

### F. H2/51

Stage to display the software version and other indications.

- Final stage: It displays error messages <sup>(C)</sup> or warnings <sup>(D)</sup> on the display when they come up. When the series ends, it begins a new sequence again repeating these messages again.

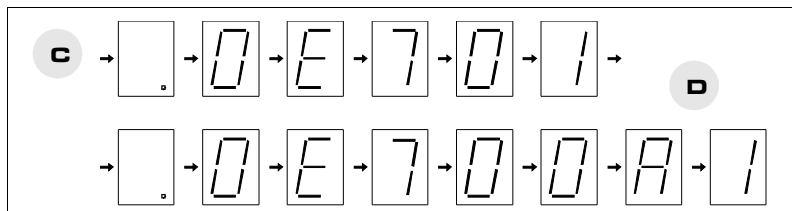

### F. H2/52

Final stage. Error and warning displaying STAGE.

See the meaning of errors and warnings that may be shown on the display in chapter 14. **ERROR CODES AND MESSAGES** of the “man\_dds\_soft.pdf” manual.

The system will not start running until all the errors detected at the power supply have been eliminated.

To eliminate these errors, their cause has to have disappeared and, then an “error reset” must be carried out. This “RESET” may be activated from the RESET button that the power supply has on top of the status display and the switches for selecting the DC BUS voltage.

1. For RPS power supplies:  
Apply power to the auxiliary power supply and close the main internal contactor - short-circuit NS1 and NS2 (pins 3 and 4) of connector X3 -.



DDS  
HARDWARE

Ref.1310

2. The power supply checks the system status:

**If the status is correct:**

The **System OK** contact closes (pins 6 and 7 of X6) and it stays closed while the control circuits are powered and no error comes up in any of the modules of the system.

The red <FAULT> indicator light blinks (it is not indicating an error because there are no phases yet).

**If the status is not correct:**

The red <FAULT> indicator light is permanently on (not blinking).

3. Apply power to the main power supply:

Power is applied from mains through the power connector (1) on top of the power supply (L1, L2, L3). The red <FAULT> indicator light will turn off and the smooth start-up will begin.

**NOTE.** If the PWM Enable (pin 4 of connector X6) is not active, the display will show the warning A004 and the power bus of the RPS will not start charging.

4. The green DC BUS ON light on:

Having mains voltage and being the PWM Enable signal (pin 4 of connector X6) active, after 4 seconds, the green DC BUS ON indicator light turns on meaning that the power bus has the proper dc voltage.

If for any reason an error is activated at the power supply module or at any drive module it supplies to, the system will act as follows:

1. The green indicator light DC BUS ON will turn off indicating that the power supply will stop supplying voltage to the power bus.



**DANGER.** When the DC BUS ON led turns off it may take about 4 minutes for the bus to discharge to a safe value (< 42 V DC) depending on the number of drive modules that are connected.

2. The red FAULT light will be on permanently.

With the Error Reset input (pin 1 of X6), it is possible to eliminate the errors at the drives that are part of the system - see chapter 14, section “resettable errors”, of the “man\_dds\_soft.pdf” manual - and it acts as follows:

- Its state will be 0 V DC. Activating it with 24 V DC erases all the errors stored in the memory of each drive of the system.
- Should the cause of the error persist, the corresponding module will show the same error again and it will be necessary to turn the unit back on to eliminate the error if it is a serious error.

The System Speed Enable input (pin 5 of X6) is related to the Speed Enable inputs of the drive modules.

- The state of the System Speed Enable is usually 24 V DC.
- If the System Speed Enable pin is set to 0 V DC, all the drive modules joined together by the same internal bus will brake the motors that they control with the torque corresponding to the active acceleration ramp and when stopped or when reaching the time limit to stop (programmable with parameter GP3, see chapter 13 of the “man\_dds\_soft.pdf” manual), it cancels the motor torque.

The consumption of each input is between 4.5 and 7 mA.

**NOTE.** Remember that if the RPS power supply is running, there is mains voltage and the PWM Enable signal is active. When canceling the PWM Enable signal the display shows the warning A004, turns on the FAULT LED and the power supply stops boosting the voltage causing a voltage drop with a value of  $\sqrt{2} \times V_{red}$  at the power bus. The drives connected to the power supply will interpret that the power supply is not ok.

## 2.

POWER SUPPLIES

Regenerative regulated power supplies

**FAGOR** 

**DDS  
HARDWARE**

**Ref.1310**

**2.**

**POWER SUPPLIES**  
Regenerative regulated power supplies

**Operating modes**

See the next running status diagram:

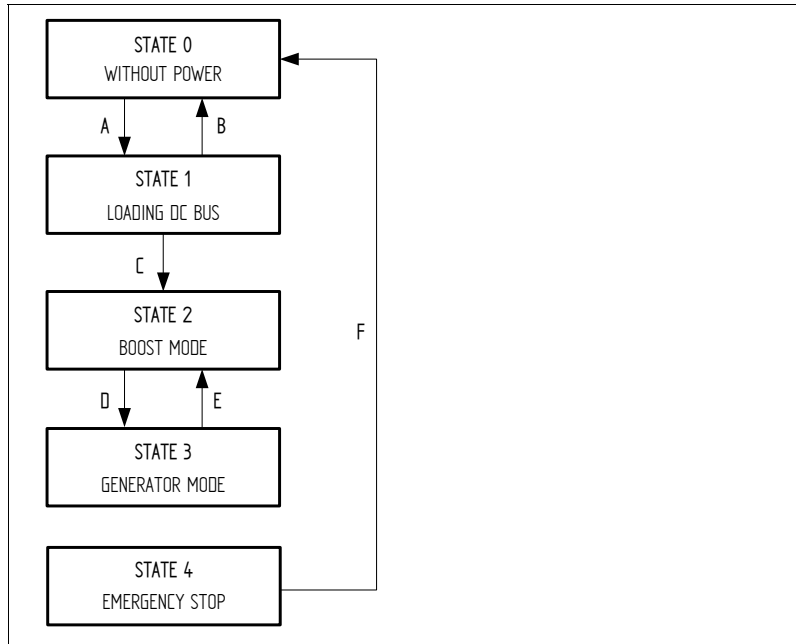

**F. H2/53**

Running state diagram of the RPS power supply.

**Running states**

Description of the possible running states:

Status	Meaning
0	Without power line connection. Stand by.
1	Loading the DC BUS. Temporary state.
2	Running in BOOST mode. The system works like a BOOST power supply.
3	Running in REGENERATOR mode. The system works as a generator discharging the excess energy of the DC BUS into mains.
4	Emergency state.

**Transitions between running states**

The transitions between states are done automatically and the system adapts itself to the relevant operating mode depending on the mains voltage and on the DC BUS voltage. These transitions are:

Transition	Meaning
A	The power line connection is made.
B	The time set as the minimum time limit (3.2 s) to charge the DC BUS has been exceeded. The charge process has failed and error E315 of the DC BUS comes up. Temporary state.
C	The charge process has finished correctly. The line voltage is within the levels set to consider it <b>working in boost mode</b> (323÷424 V AC). The DC BUS voltage is lower than 625 V DC.
D	The BUS voltage is higher than the nominal voltage set for the DC BUS and the value of the mains voltage is within the limits set to work in generator mode.
E	The BUS voltage is lower than the nominal voltage set for the DC BUS and the value of the mains voltage is within the limits set to work in boost mode.
F	The emergency stop has ended.



DDS  
HARDWARE

Ref.1310

**NOTE.** When detecting an error, it will switch from any state 0, 1, 2 or 3 directly to state 4. From any of the states, it will switch to state 0 if a stop occurs due to the NO READY state of any of the drives connected to the power supply or because the power line has been disconnected or because the emergency stop button has been pressed or because the line voltage has dropped.

Follow this sequence to stop the system without having detected any errors:

- ❑ Disabling the drives; i.e. disable the Speed Enable of all the axes or the System Speed Enable.
- ❑ Disconnecting the power line by opening the contactor - KM1, usually by pressing the E-STOP button.

**2.**

**POWER SUPPLIES**  
Regenerative regulated power supplies

**FAGOR** 

**DDS  
HARDWARE**

**Ref.1310**



The drives that make up Fagor's DDS servo drive system are modular and stackable. They are connected directly to three-phase mains with a rated mains voltage between 400-10% and 460+10% V AC at a mains frequency of 50/60 Hz. Its features are:

- supply the motor with a three-phase 400 - 4.5% V AC.
- provide the motor with a variable frequency to control its speed and position.

Hence, we refer to:

#### **Modular drives**

**AXD** Digital module that can govern a synchronous motor in speed and position working as an axis.

**SPD** Digital module that can govern a synchronous or an asynchronous motor in speed and position working as a spindle.

**MMC** Digital module that can govern a synchronous motor in speed and position working as an axis or a spindle and also generate a tool path.

#### **Compact drives**

**ACD** Digital module that can govern a synchronous motor in speed and position working as an axis.

**SCD** Digital module that can govern a synchronous or an asynchronous motor in speed and position working as a spindle.

**CMC** Digital module that can govern a synchronous motor in speed and position working as an axis or a spindle and also generate a tool path.

The drive modules just mentioned can operate with the following motors:

**SYNCHRONOUS** FXM and FKM families.

**ASYNCHRONOUS** FM7 and FM9 families.

The following sections analyze all of them showing their technical characteristics and other considerations.

### 3.1 Modular drives

When referring to modular drives, we will use AXD, SPD and MMC. They all admit a voltage range between 400 to 460 V AC. See all models in the following figures.

**3.**  
**DRIVE MODULES**  
Modular drives

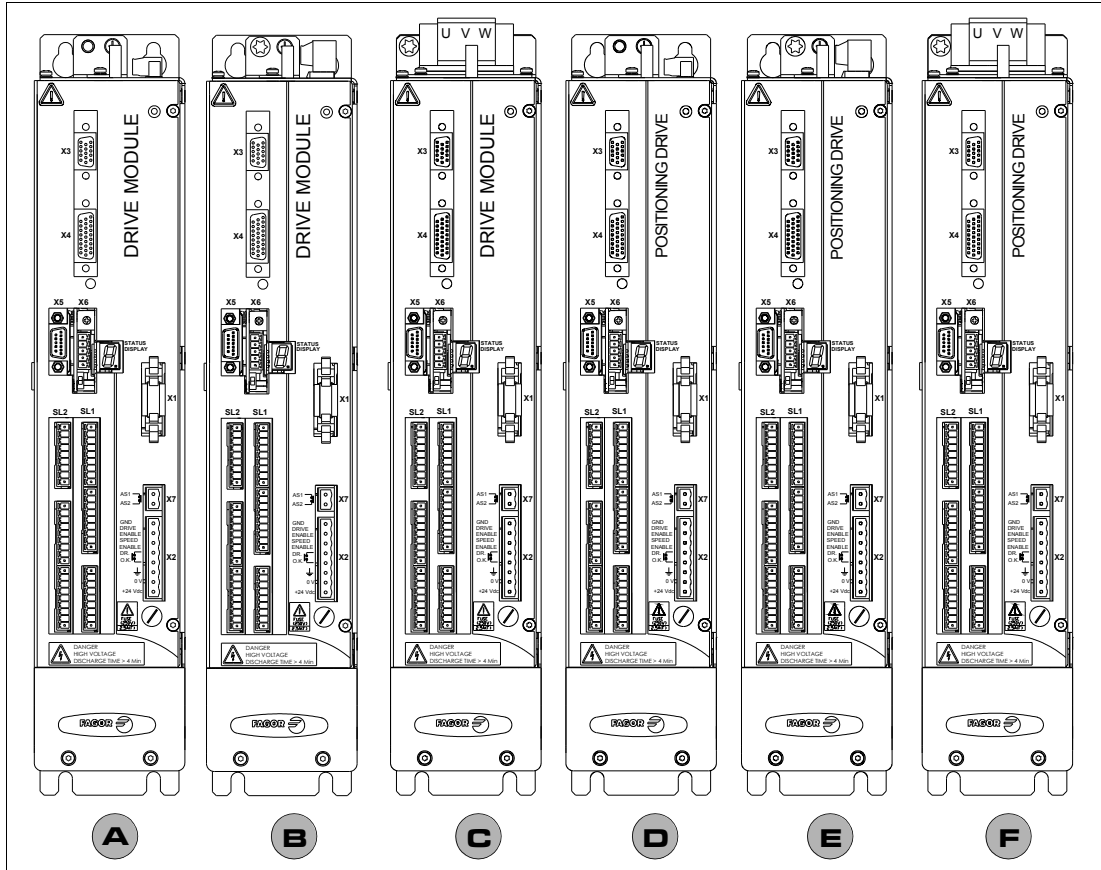

**F. H3/1**

Size-1 modular drives of the FAGOR catalog.

**A.** AXD/SPD 1.08/1.15, **B.** AXD/SPD 1.25, **C.** AXD/SPD 1.35, **D.** MMC 1.08/1.15, **E.** MMC 1.25, **F.** MMC 1.35

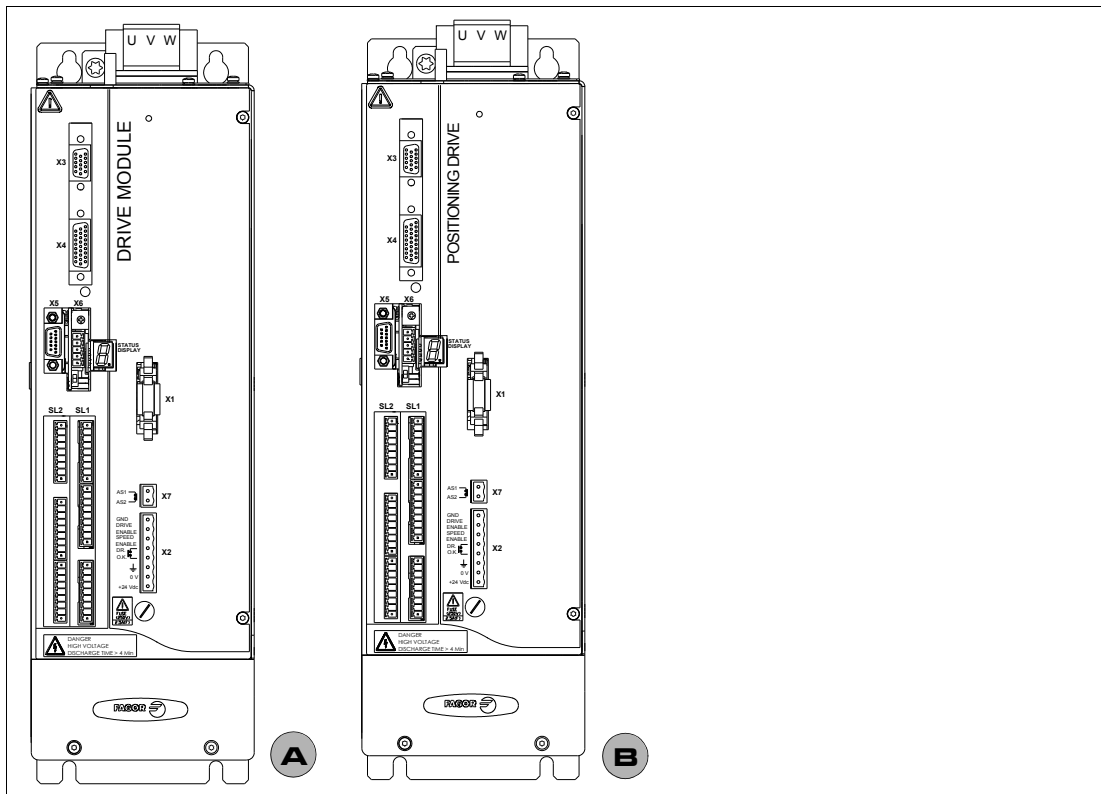

**F. H3/2**

Size-2 modular drives of the FAGOR catalog.

**A.** AXD/SPD 2.50/2.75, SPD 2.85, **B.** MMC 2.50/2.75.



DDS  
HARDWARE

Ref.1310

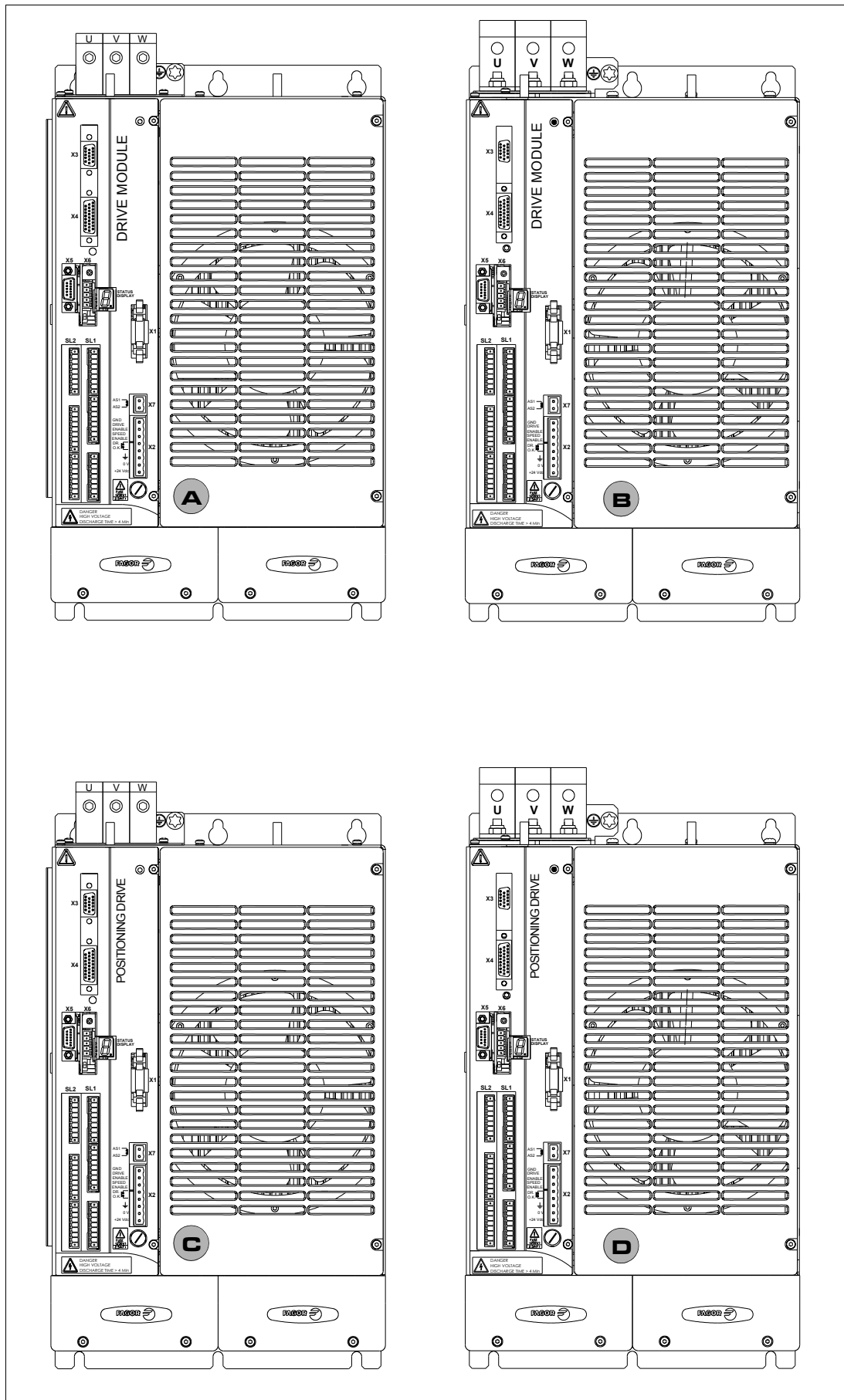

**F. H3/3**

Size-3 modular drives of the FAGOR catalog.

A. AXD/SPD 3.100/3.150, B. SPD 3.200/3.250, C. MMC 3.100/3.150, D. MMC 3.200.

**3.**

**DRIVE MODULES**  
Modular drives



**DDS  
HARDWARE**

**Ref.1310**

### Technical data

There are specific modular drives AXD to control synchronous motors (both for axis and spindle applications) and SPD to control asynchronous motors (in spindle applications). This chapter is common to both models because their external characteristics (dimensions, connectors, ...) are the same.

**3.**  
**DRIVE MODULES**  
Modular drives

**T. H3/1** Currents on modular drives for synchronous motors.  $f_c = 4$  kHz.

With internal fan	Drive for synchronous motor (as axis)								
Models	AXD MMC 1.08	AXD MMC 1.15	AXD MMC 1.25	AXD MMC 1.35	AXD MMC 2.50	AXD MMC 2.75	AXD MMC 3.100	AXD MMC 3.150	MMC 3.200
I S1= In Arms	4.0	7.5	12.5	17.5	25.0	37.5	50.0	75.0	90.0
I <sub>max</sub> S1 Arms	8.0	15.0	25.0	35.0	50.0	75.0	100.0	150.0	180.0
Dissipated power W	33	69	88	156	225	270	351	536	834

**T. H3/2** Currents on modular drives for synchronous motors.  $f_c = 8$  kHz.

With internal fan	Drive for synchronous motor (as axis)								
Models	AXD MMC 1.08	AXD MMC 1.15	AXD MMC 1.25	AXD MMC 1.35	AXD MMC 2.50	AXD MMC 2.75	AXD MMC 3.100	AXD MMC 3.150	MMC 3.200
I S1= In Arms	4.0	7.5	12.5	17.5	25.0	37.5	50.0	75.0	90.0
I <sub>max</sub> S1 Arms	8.0	15.0	25.0	35.0	50.0	75.0	100.0	150.0	180.0
Dissipated power W	44	89	132	195	305	389	510	605	840

**T. H3/3** Current in modular drives for synchronous or asynchronous motors.  $f_c = 4$  kHz.

With internal fan	Drive for synchronous or asynchronous motor (as spindle)									
Models	SPD 1.15	SPD 1.25	SPD 1.35	SPD 2.50	SPD 2.75	SPD 2.85	SPD 3.100	SPD 3.150	SPD 3.200	SPD 3.250
I S1= In Arms	10.5	16.0	23.1	31.0	42.0	50.0	70.0	90.0	121.0	135.0
0.7 x In Arms	7.3	11.2	16.1	21.7	29.0	35.0	49.0	63.0	84.7	94.5
I S6-40 Arms	13.7	20.8	30.0	40.3	54.6	65.0	91.0	117.0	157.3	175.5
Dissipated power W	98	110	195	349	289	432	496	626	1163	1333

**T. H3/4** Current in modular drives for synchronous or asynchronous motors.  $f_c = 8$  kHz.

With internal fan	Drive for synchronous or asynchronous motor (as spindle)									
Models	SPD 1.15	SPD 1.25	SPD 1.35	SPD 2.50	SPD 2.75	SPD 2.85	SPD 3.100	SPD 3.150	SPD 3.200	SPD 3.250
I S1= In Arms	10.5	13.0	18.0	27.0	32.0	37.0	56.0	70.0	97.0	108.0
0.7 x In Arms	7.3	9.1	12.6	18.9	22.4	25.9	39.2	49.7	67.9	75.6
I S6-40 Arms	11.6	16.9	23.4	35.1	41.6	48.1	72.8	91.0	126.1	140.4
Dissipated power W	98	130	201	350	333	438	546	668	1187	1344

**Note that:**

MMC drives have the same currents as AXD drives.  
**f<sub>c</sub>**. It represents the switching frequency of the IGBT's  
 The dissipated powers correspond to the operation at the rated current in S1 mode.  
 See the load duty cycle for the modular drives in the corresponding section of this chapter.



DDS  
HARDWARE

Ref.1310

**T. H3/5** Technical characteristics of the modular drives.

		<b>AXD/SPD/MMC</b>								
		<b>1.08</b>	<b>1.15</b>	<b>1.25</b>	<b>1.35</b>	<b>2.50</b>	<b>2.75</b>	<b>2.85</b>	<b>3.100</b> <b>3.150</b>	<b>3.200</b> <b>3.250</b>
Power voltage input		542 - 800 V DC								
Power to control circuits		24 V DC (between 21 V DC and 28 V DC)								
Consumption of the control circuits (24 V DC)		0.90 A			1.25 A			2.00 A		
Speed feedback		Encoder								
Controlling method		PWM, AC sinewave, vector control								
Communication		Serial line to connect to a PC								
Interface		Standard analog, digital SERCOS ring (in all models) CAN bus (in all models). Serial line RS-232/422 (only in MMC drives)								
Status display		7-segments display								
Protections		Over-voltage, over-current, over-speed, heat-sink temperature, ambient temperature, motor temperature, hardware error, overload.								
Speed range with analog input		1:8192								
Current bandwidth		800 Hz								
Speed bandwidth		100 Hz (depends on the motor/drive set)								
Ambient temperature		Between 5 °C and 45 °C (41 °F/113 °F) From 40 °C (104 °F) on. See derating curves.								
Storage temperature		Between - 20 °C and + 60 °C (- 4 °F/140 °F)								
Sealing		IP 20								
Maximum humidity		< 90% (non condensing at 45 °C/113 °F)								
Operating vibration		0.5 G								
Shipping vibration		2 G								
Approx. mass in	kg lb	5.5 (12.1)	6.0 (13.2)	6.5 (14.3)	9.0 (19.8)	9.0 (19.8)	10.0 (22.0)	14.0 (30.8)	19.5 (43.0)	

**3.****DRIVE MODULES**  
Modular drives**FAGOR** **DDS**  
**HARDWARE**

Ref.1310

### Load duty cycles

#### Load cycle S1

**Continuous duty.** Operation with constant load and long enough to achieve thermal balance.

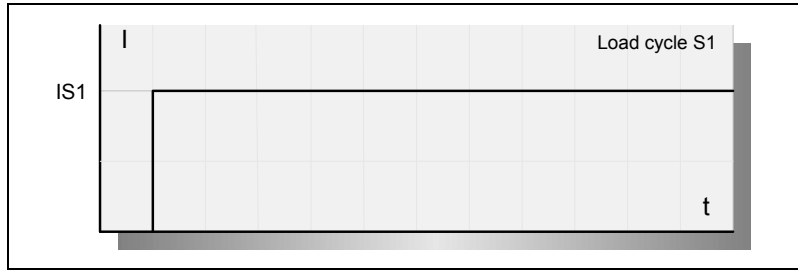

**F. H3/4**

Load cycle S1.

#### Load cycle S1 with current peak

**Periodic intermittent duty.** Succession of identical duty cycles each having a period at constant maximum load and a period at constant rated load. In this duty cycle, the overheating effect of the start-up current is negligible. The 5% running factor means that for a 10 second cycle, it works at constant current  $I_{max}$  ( $2 \times I_{nom}$ ) for 0.5 seconds and at rated current ( $I_{nom}$ ) for 9.5 seconds.

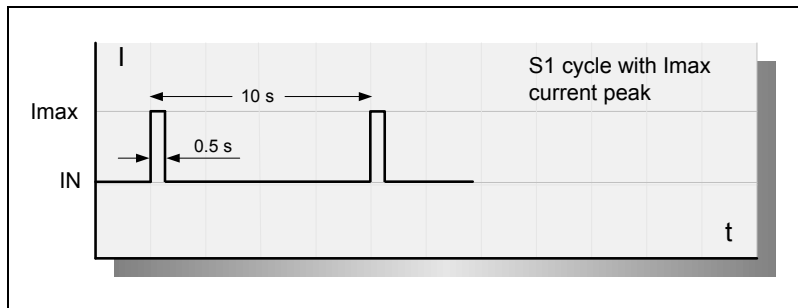

**F. H3/5**

Load cycle S1 with current peak  $I_{max}$ .

#### Load cycle S6-40

**Periodic uninterrupted duty cycle with intermittent load.** Succession of identical duty cycles, each with a running period under constant load and another period without load. There is no rest period. The 40% running factor indicates that for a 10 minute cycle, it works at constant current for 4 minutes ( $I_{S6-40}$ ) and without load for 6 minutes (with magnetizing current =  $0.7 \times$  rated current  $I_N$ ).

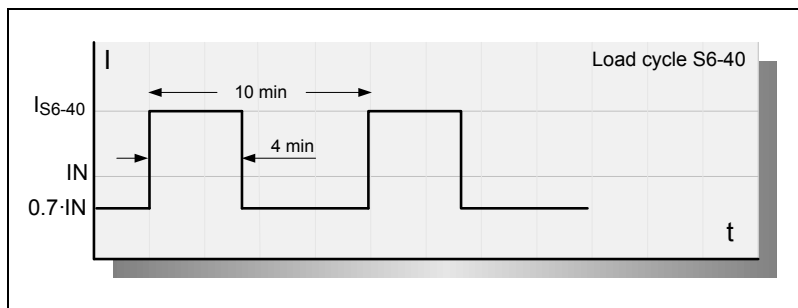

**F. H3/6**

Load cycle S6-40.



DDS  
 HARDWARE

Ref.1310

## Current derating

### Drives for an synchronous motor working as an axis

The following graphs show the maximum rms current in continuous S1 ( $I_n$ ) and intermittent S3-5% ( $I_{max}$  and  $I_n$ ) duty cycles depending on the switching frequency of the power transistors in a temperature range between 5 °C (41 °F) and 60 °C (140 °F).

See the load duty cycles.

**3.****DRIVE MODULES**  
Modular drives**FAGOR** **DDS  
HARDWARE****Ref.1310**

□ For a switching frequency  $f_c = 4 \text{ kHz}$

**3.**

DRIVE MODULES  
Modular drives

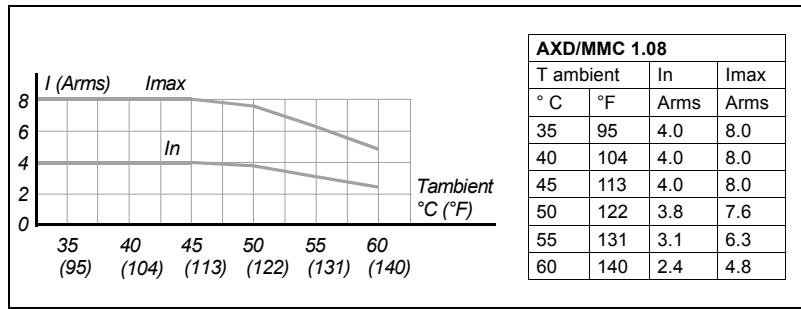

**F. H3/7**

Current derating on “AXD/MMC 1.08” drives for  $f_c = 4 \text{ kHz}$ .

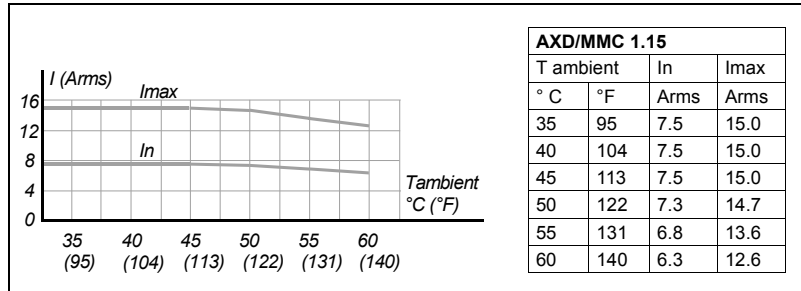

**F. H3/8**

Current derating on “AXD/MMC 1.15” drives for  $f_c = 4 \text{ kHz}$ .

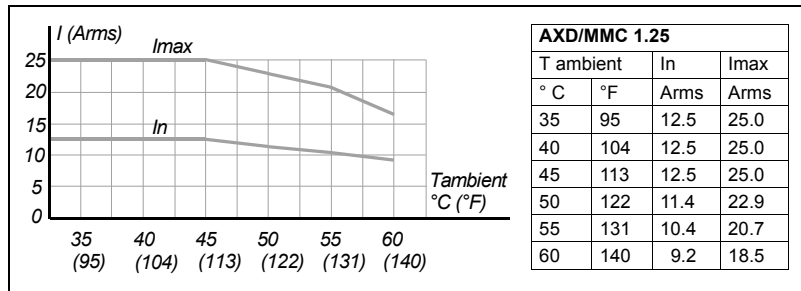

**F. H3/9**

Current derating on “AXD/MMC 1.25” drives for  $f_c = 4 \text{ kHz}$ .

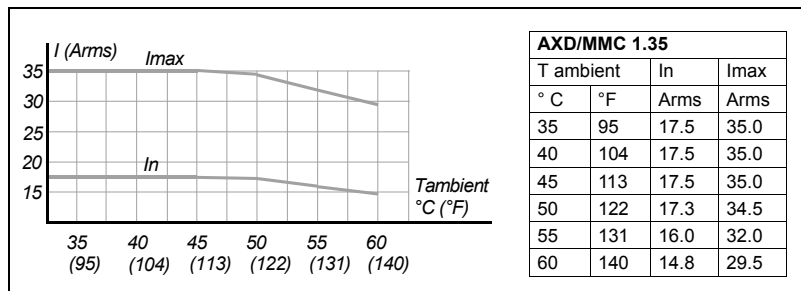

**F. H3/10**

Current derating on “AXD/MMC 1.35” drives for  $f_c = 4 \text{ kHz}$ .

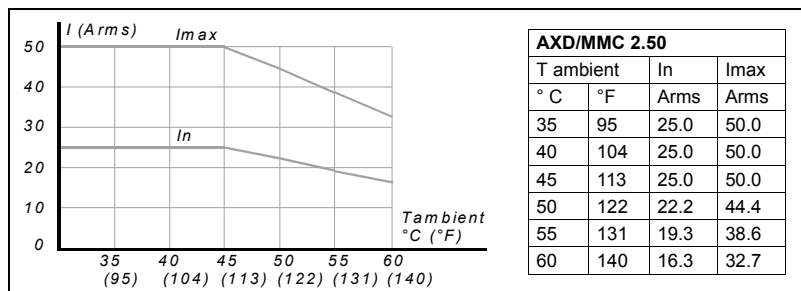

**F. H3/11**

Current derating on “AXD/MMC 2.50” drives for  $f_c = 4 \text{ kHz}$ .



DDS  
HARDWARE

Ref.1310

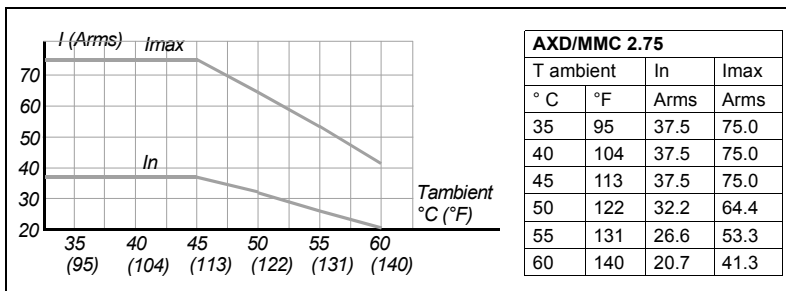

**F. H3/12**

Current derating on “AXD/MMC 2.75” drives for  $f_c = 4$  kHz.

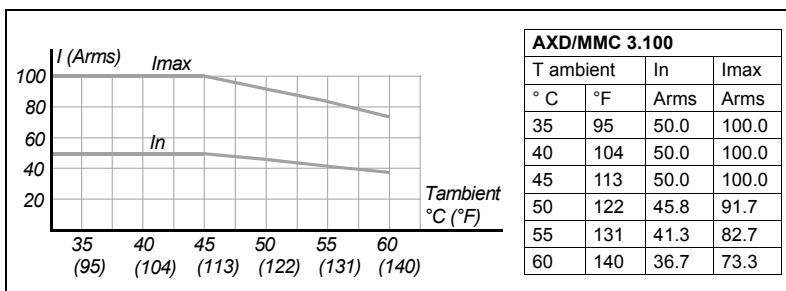

**F. H3/13**

Current derating on “AXD/MMC 3.100” drives for  $f_c = 4$  kHz.

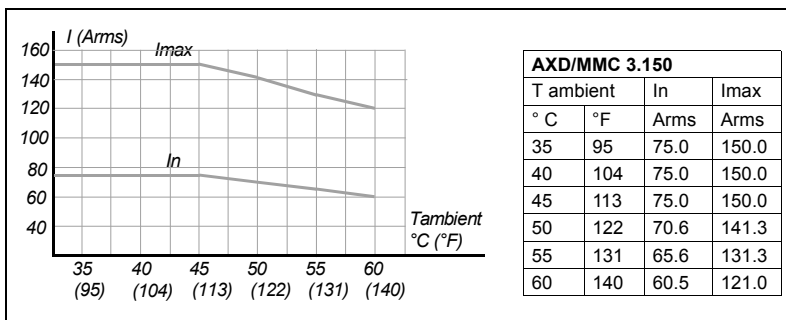

**F. H3/14**

Current derating on “AXD/MMC 3.150” drives for  $f_c = 4$  kHz.

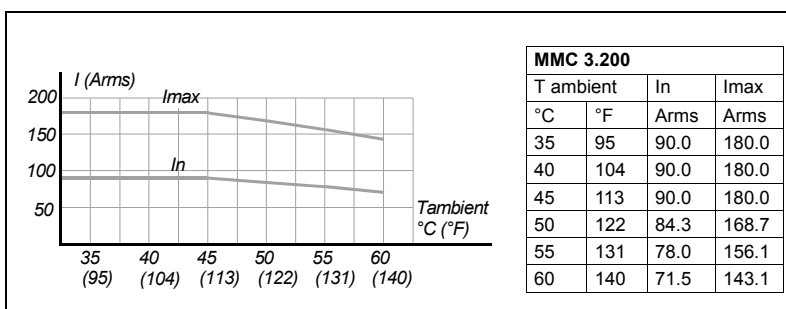

**F. H3/15**

Current derating on “MMC 3.200” drives for  $f_c = 4$  kHz.

**3.**

**DRIVE MODULES**  
Modular drives



**DDS  
HARDWARE**

**Ref.1310**

□ For a switching frequency  $f_c = 8 \text{ kHz}$

**3.**

DRIVE MODULES  
Modular drives

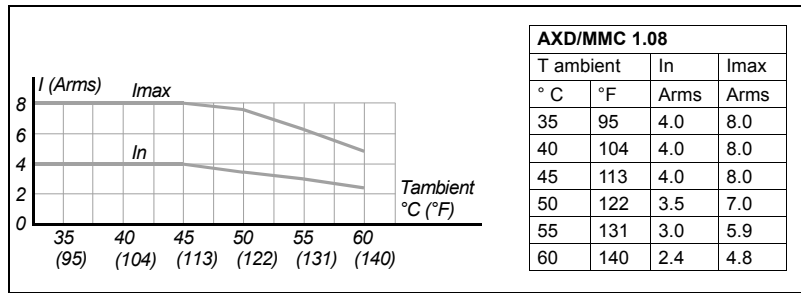

**F. H3/16**

Current derating on "AXD/MMC 1.08" drives for  $f_c = 8 \text{ kHz}$ .

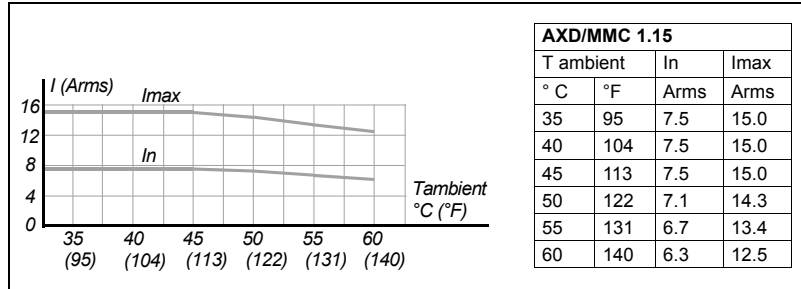

**F. H3/17**

Current derating on "AXD/MMC 1.15" drives for  $f_c = 8 \text{ kHz}$ .

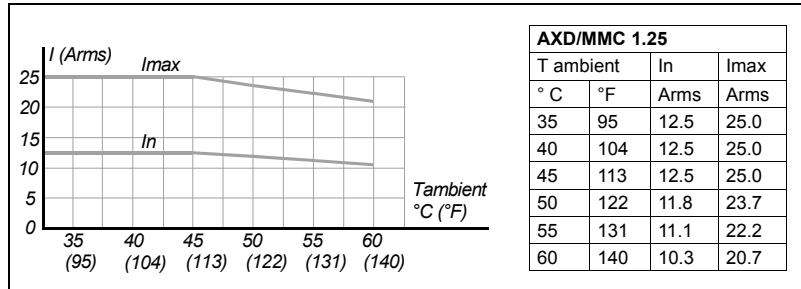

**F. H3/18**

Current derating on "AXD/MMC 1.25" drives for  $f_c = 8 \text{ kHz}$ .

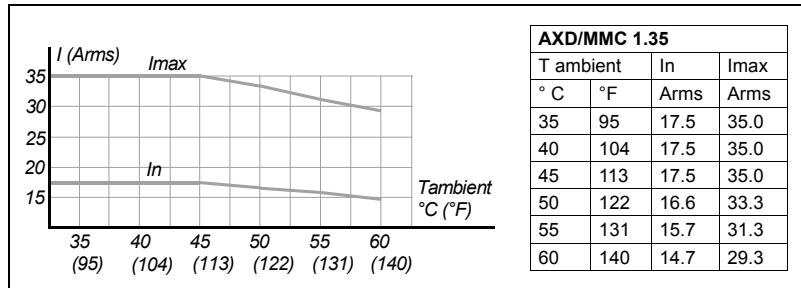

**F. H3/19**

Current derating on "AXD/MMC 1.35" drives for  $f_c = 8 \text{ kHz}$ .

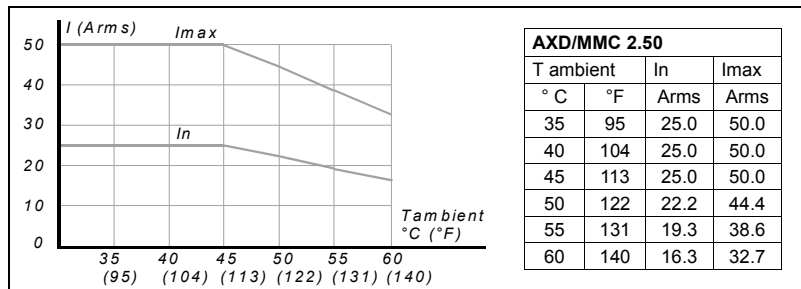

**F. H3/20**

Current derating on "AXD/MMC 2.50" drives for  $f_c = 8 \text{ kHz}$ .



DDS  
HARDWARE

Ref.1310

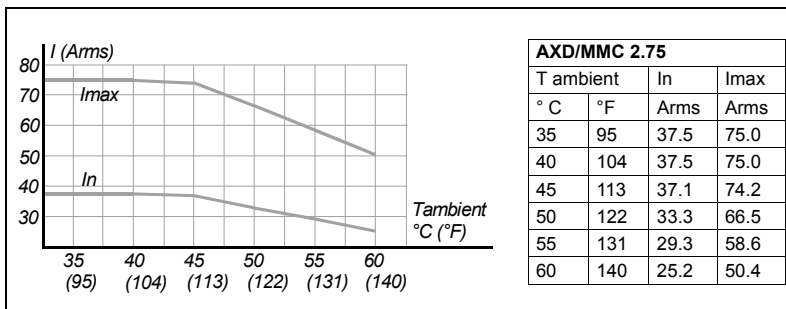

**F. H3/21**

Current derating on “AXD/MMC 2.75” drives for  $f_c = 8$  kHz.

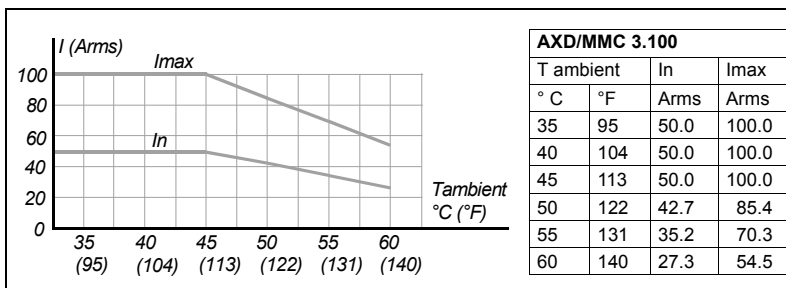

**F. H3/22**

Current derating on “AXD/MMC 3.100” drives for  $f_c = 8$  kHz.

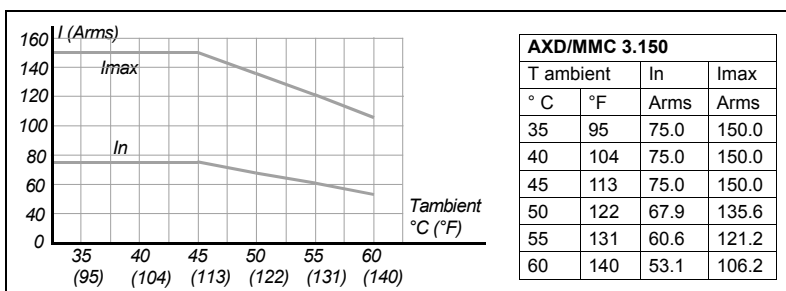

**F. H3/23**

Current derating on “AXD/MMC 3.150” drives for  $f_c = 8$  kHz.

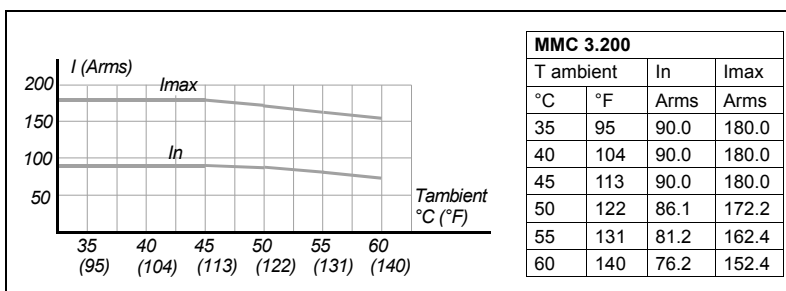

**F. H3/24**

Current derating on “MMC 3.200” drives for  $f_c = 8$  kHz.

**3.**

**DRIVE MODULES**  
Modular drives



**DDS  
HARDWARE**

**Ref.1310**

# 3.

## DRIVE MODULES Modular drives

### Drives for a synchronous or asynchronous motor working as a spindle

The following graphs show the maximum rms current in continuous S1 (I<sub>n</sub>) and intermittent S6-40 (I<sub>S6-40</sub>) duty cycles depending on the switching frequency of the power transistors in a temperature range between 5 °C (41 °F) and 60 °C (140 °F).

See the load duty cycles.



DDS  
HARDWARE

Ref.1310

■ For a switching frequency  $f_c = 4$  kHz

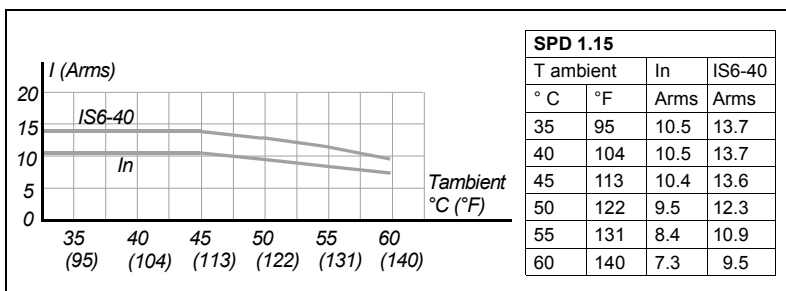

**F. H3/25**

Current derating on “SPD 1.15” drives for  $f_c = 4$  kHz.

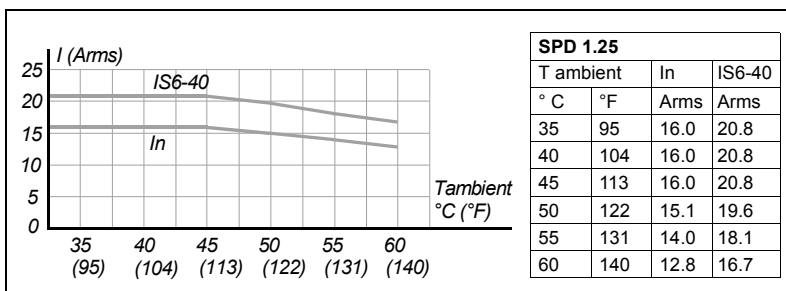

**F. H3/26**

Current derating on “SPD 1.25” drives for  $f_c = 4$  kHz.

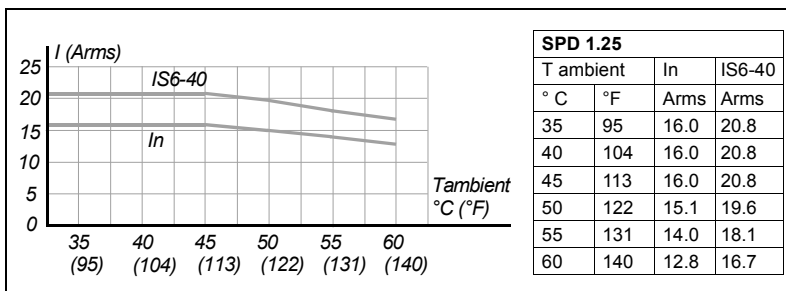

**F. H3/27**

Current derating on “SPD 1.35” drives for  $f_c = 4$  kHz.

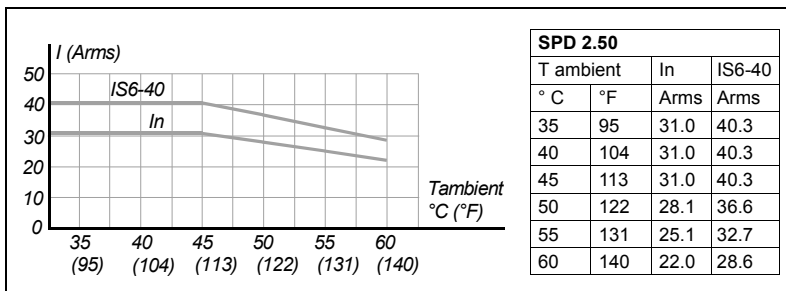

**F. H3/28**

Current derating on “SPD 2.50” drives for  $f_c = 4$  kHz.

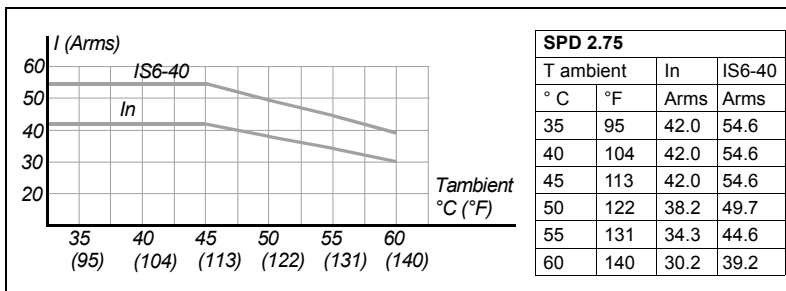

**F. H3/29**

Current derating on “SPD 2.75” drives for  $f_c = 4$  kHz.

**3.**  
DRIVE MODULES  
Modular drives



DDS  
HARDWARE

Ref.1310

# 3.

DRIVE MODULES  
Modular drives

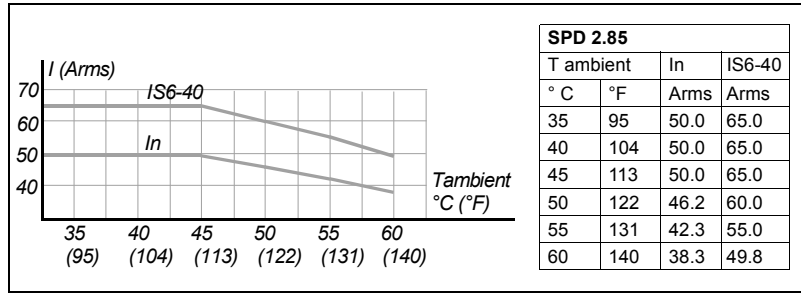

### F. H3/30

Current derating on "SPD 2.85" drives for  $f_c = 4$  kHz.

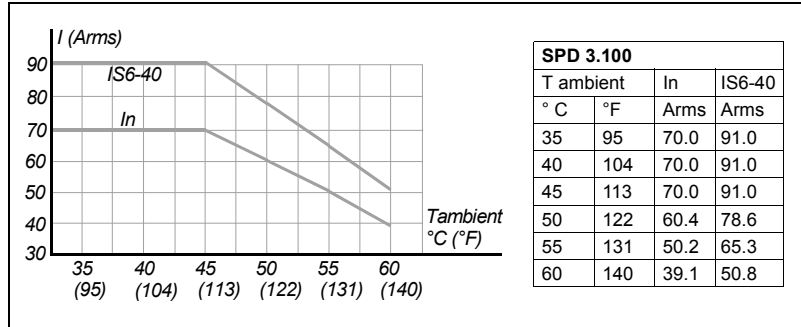

### F. H3/31

Current derating on "SPD 3.100" drives for  $f_c = 4$  kHz.

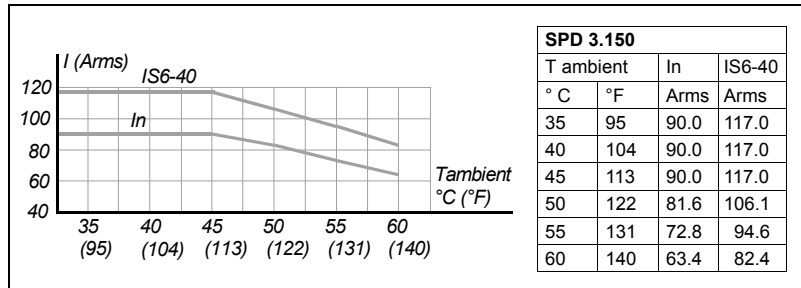

### F. H3/32

Current derating on "SPD 3.150" drives for  $f_c = 4$  kHz.

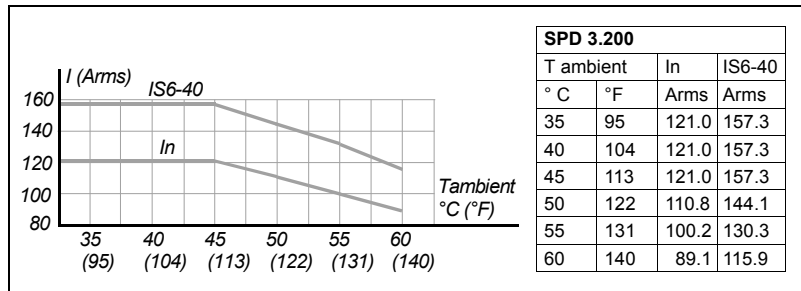

### F. H3/33

Current derating on "SPD 3.200" drives for  $f_c = 4$  kHz.

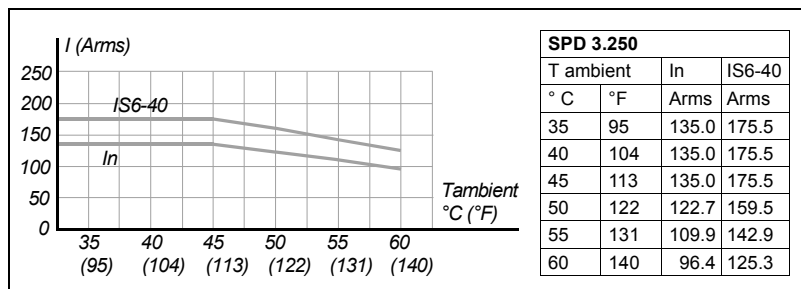

### F. H3/34

Current derating on "SPD 3.250" drives for  $f_c = 4$  kHz.



DDS  
HARDWARE

Ref.1310

■ For a switching frequency  $f_c = 8$  kHz

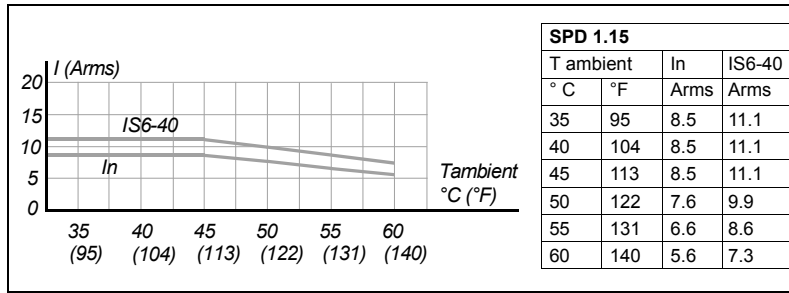

**F. H3/35**

Current derating on “SPD 1.15” drives for  $f_c = 8$  kHz.

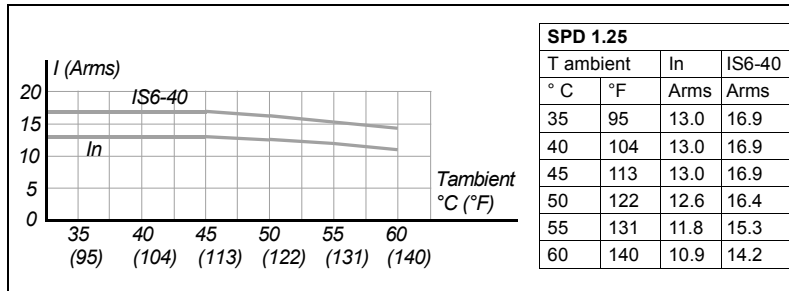

**F. H3/36**

Current derating on “SPD 1.25” drives for  $f_c = 8$  kHz.

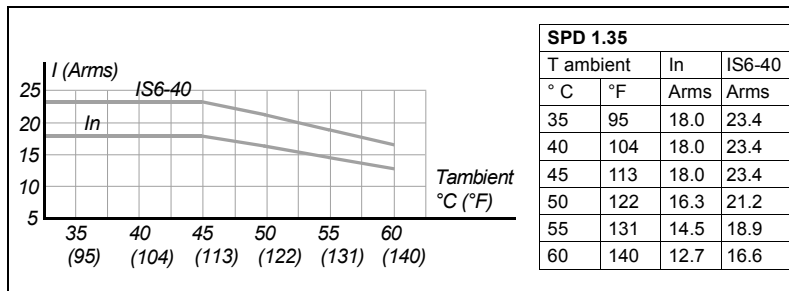

**F. H3/37**

Current derating on “SPD 1.35” drives for  $f_c = 8$  kHz.

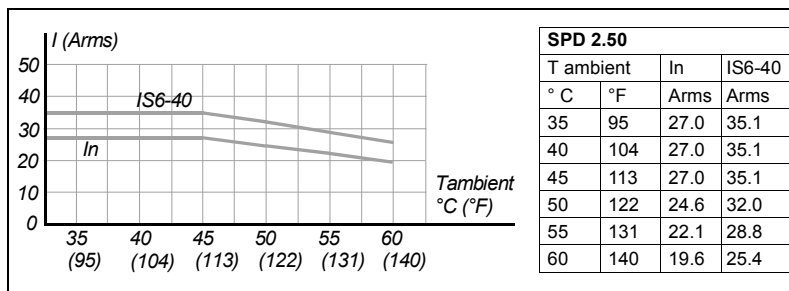

**F. H3/38**

Current derating on “SPD 2.50” drives for  $f_c = 8$  kHz.

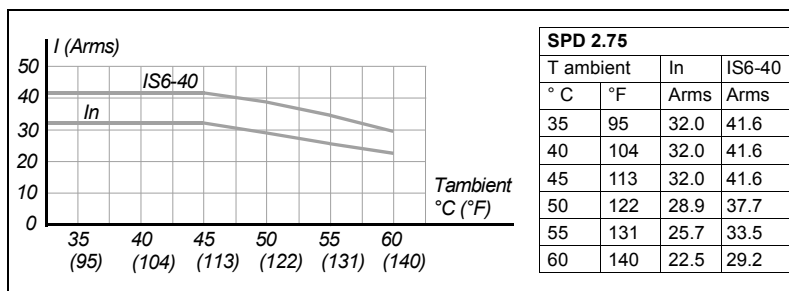

**F. H3/39**

Current derating on “SPD 2.75” drives for  $f_c = 8$  kHz.

**3.**  
DRIVE MODULES  
Modular drives



DDS  
HARDWARE

Ref.1310

# 3.

**DRIVE MODULES**  
Modular drives

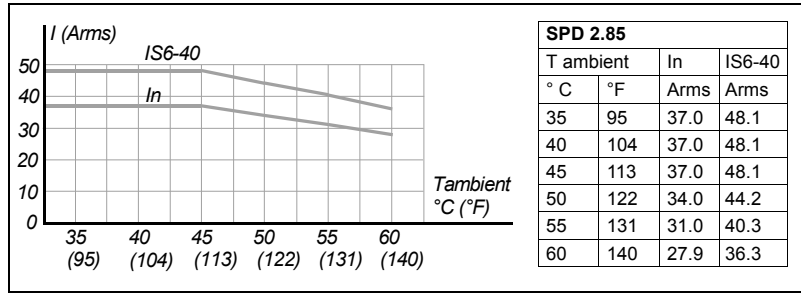

### F. H3/40

Current derating on "SPD 2.85" drives for  $f_c = 8$  kHz.

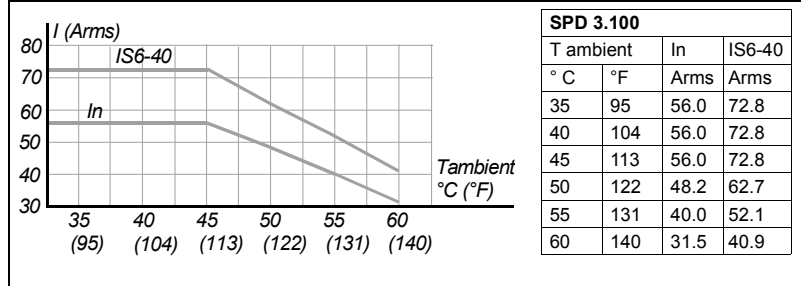

### F. H3/41

Current derating on "SPD 3.100" drives for  $f_c = 8$  kHz.

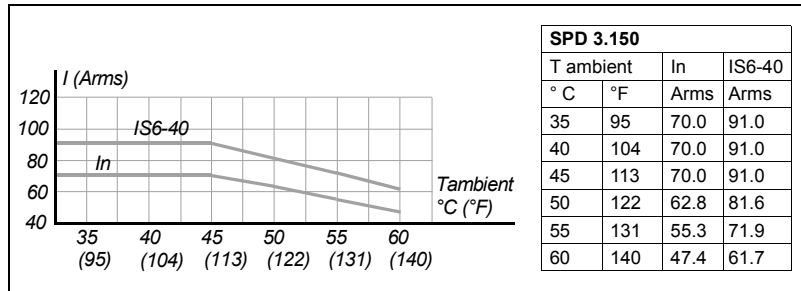

### F. H3/42

Current derating on "SPD 3.150" drives for  $f_c = 8$  kHz.

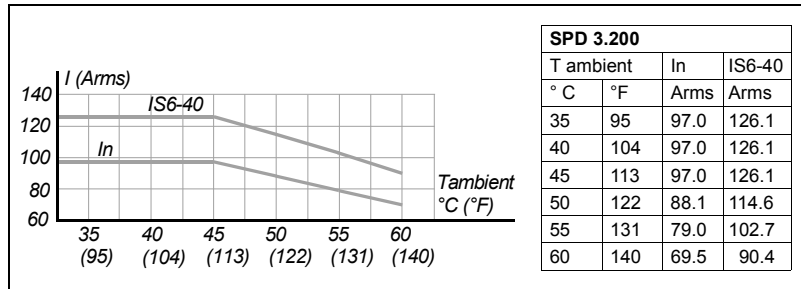

### F. H3/43

Current derating on "SPD 3.200" drives for  $f_c = 8$  kHz.

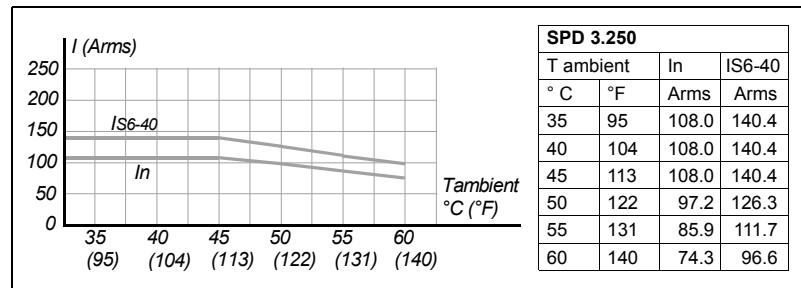

### F. H3/44

Current derating on "SPD 3.250" drives for  $f_c = 8$  kHz.



DDS  
HARDWARE

Ref.1310

### Power derating

The following graph shows the variation suffered by the output rated power of the modular drive (for all its models) depending on the installation altitude over sea level.

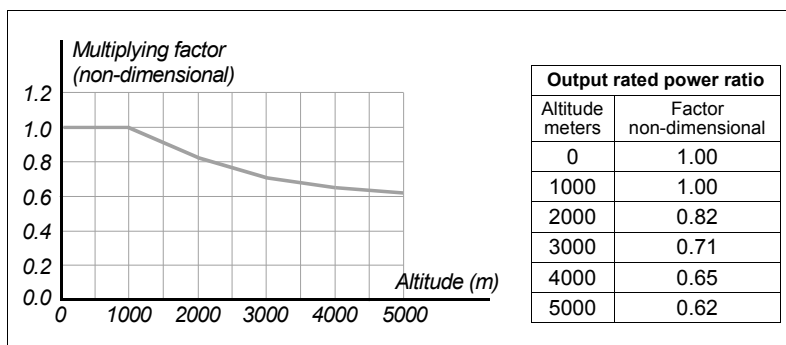

#### F. H3/45

Derating of rated output power depending on the above-sea-level altitude of the installation.

**3.**  
**DRIVE MODULES**  
 Modular drives



**DDS  
 HARDWARE**

**Ref.1310**

Block diagram

**3.**

**DRIVE MODULES**  
Modular drives

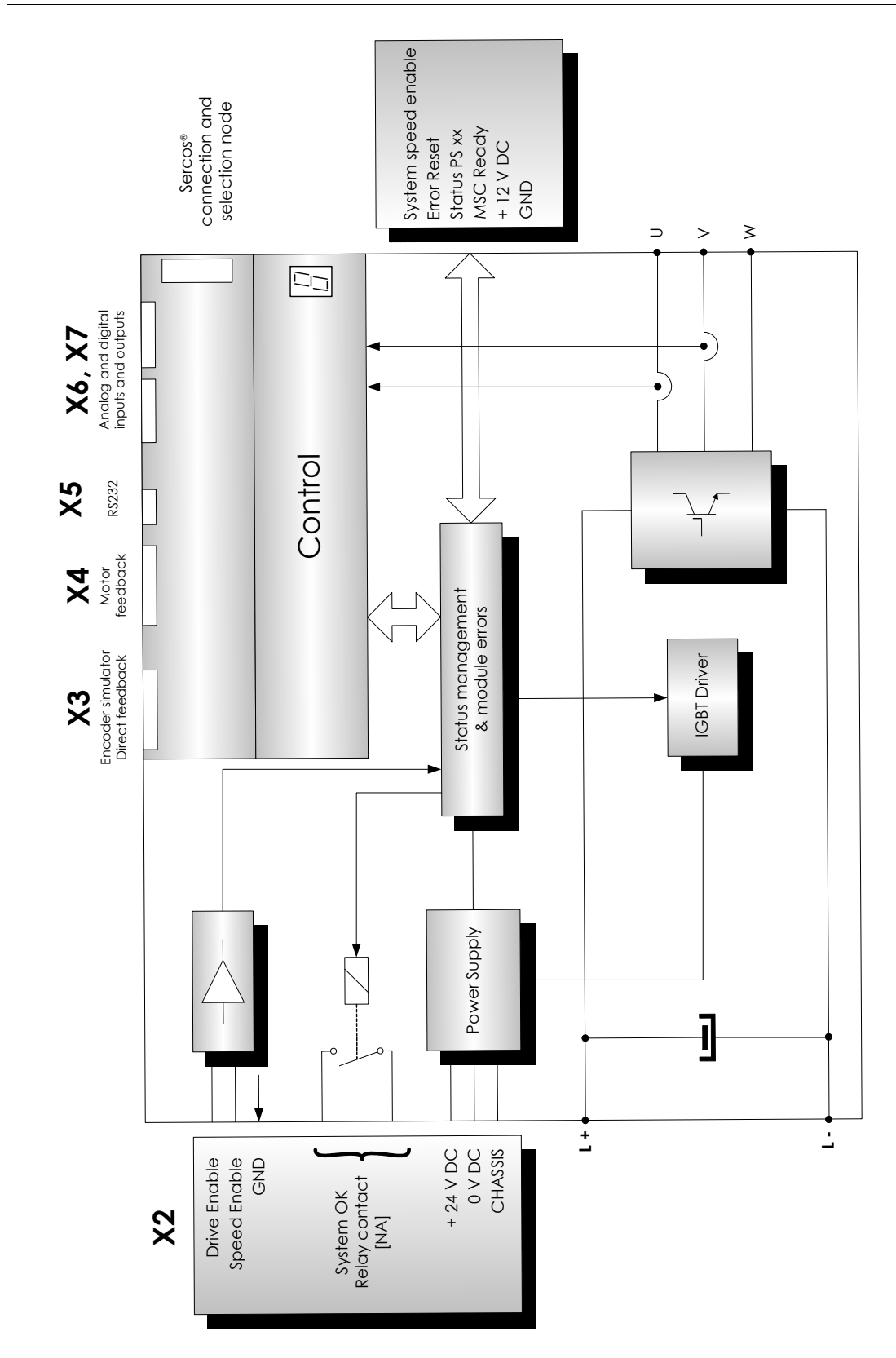

F. H3/46

Block diagram of modular drives AXD and SPD.



DDS  
HARDWARE

Ref.1310

## Connector layout

### AXD/SPD 1.08/1.15

These drive modules have the following connectors:

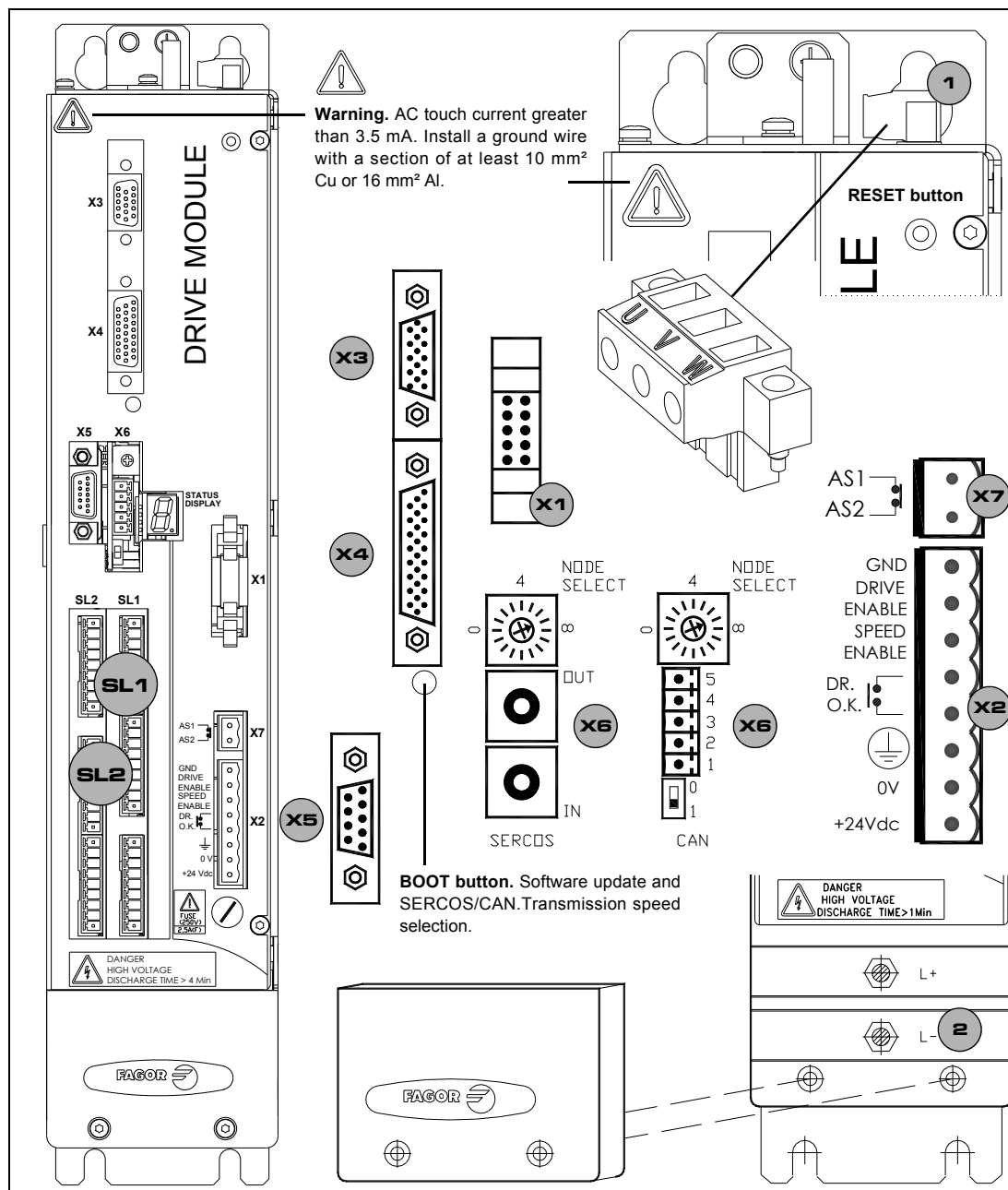

#### F. H3/47

Connectors of "AXD/SPD 1.08/1.15" modular drives.

1. Power connector for motor connection.
2. Power bus that feeds the drive modules from the power supply through metal plates.
- X1. Connector that may be used to establish communication between modules through the internal bus.
- X2. Connector for the basic control signals.
- X3. Connector with two possible uses:
  - as output of the encoder simulator.
  - as input of the direct feedback for the position loop.
- X4. Connector for motor feedback connection (encoder).
- X5. Connector for RS-232 serial line connection.
- X6. SERCOS or CAN interface connector.
- X7. Connector for external acknowledgment of the status of the safety relay.
- SL1. Slot for the cards A1, 16DI-8DO and 8DI-16DO.
- SL2. Slot for the cards 16DI-8DO and 8DI-16DO.

**3.**  
DRIVE MODULES  
Modular drives

**FAGOR**

DDS  
HARDWARE

Ref.1310

**AXD/SPD 1.25**

These drive modules have the following connectors:

**3.**  
**DRIVE MODULES**  
Modular drives

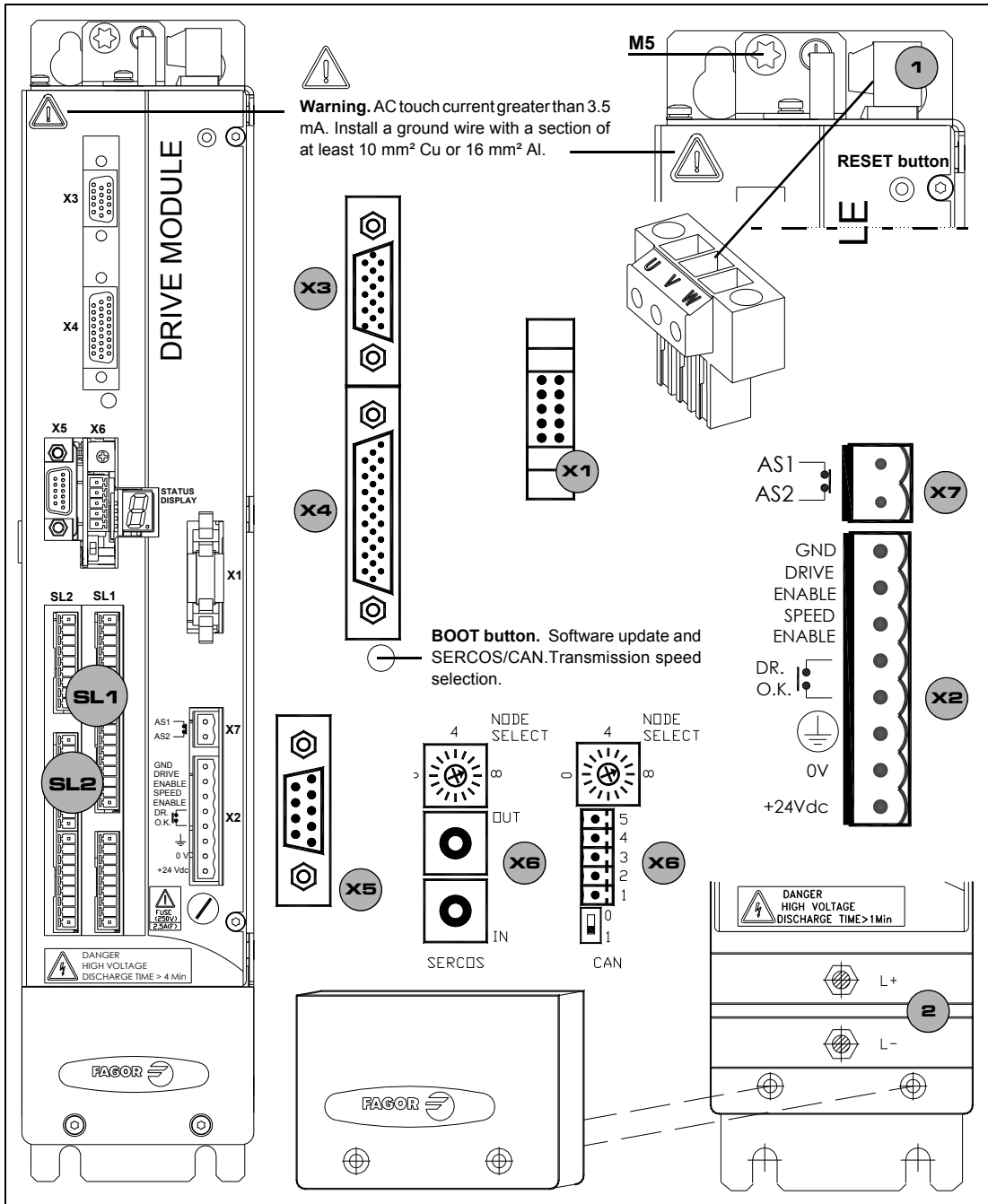

**F. H3/48**

Connectors of "AXD/SPD 1.25" modular drives.

- 1. Power connector for motor connection.
- 2. Power bus that feeds the drive modules from the power supply through metal plates.
- X1. Connector that may be used to establish communication between modules through the internal bus.
- X2. Connector for the basic control signals.
- X3. Connector with two possible uses:
  - as output of the encoder simulator.
  - as input of the direct feedback for the position loop.
- X4. Connector for motor feedback connection (encoder).
- X5. Connector for RS-232 serial line connection.
- X6. SERCOS or CAN interface connector.
- X7. Connector for external acknowledgment of the status of the safety relay.
- SL1. Slot for the cards A1, 16DI-8DO and 8DI-16DO.
- SL2. Slot for the cards 16DI-8DO and 8DI-16DO.



DDS  
HARDWARE

Ref.1310

**AXD/SPD 1.35**

These drive modules have the following connectors:

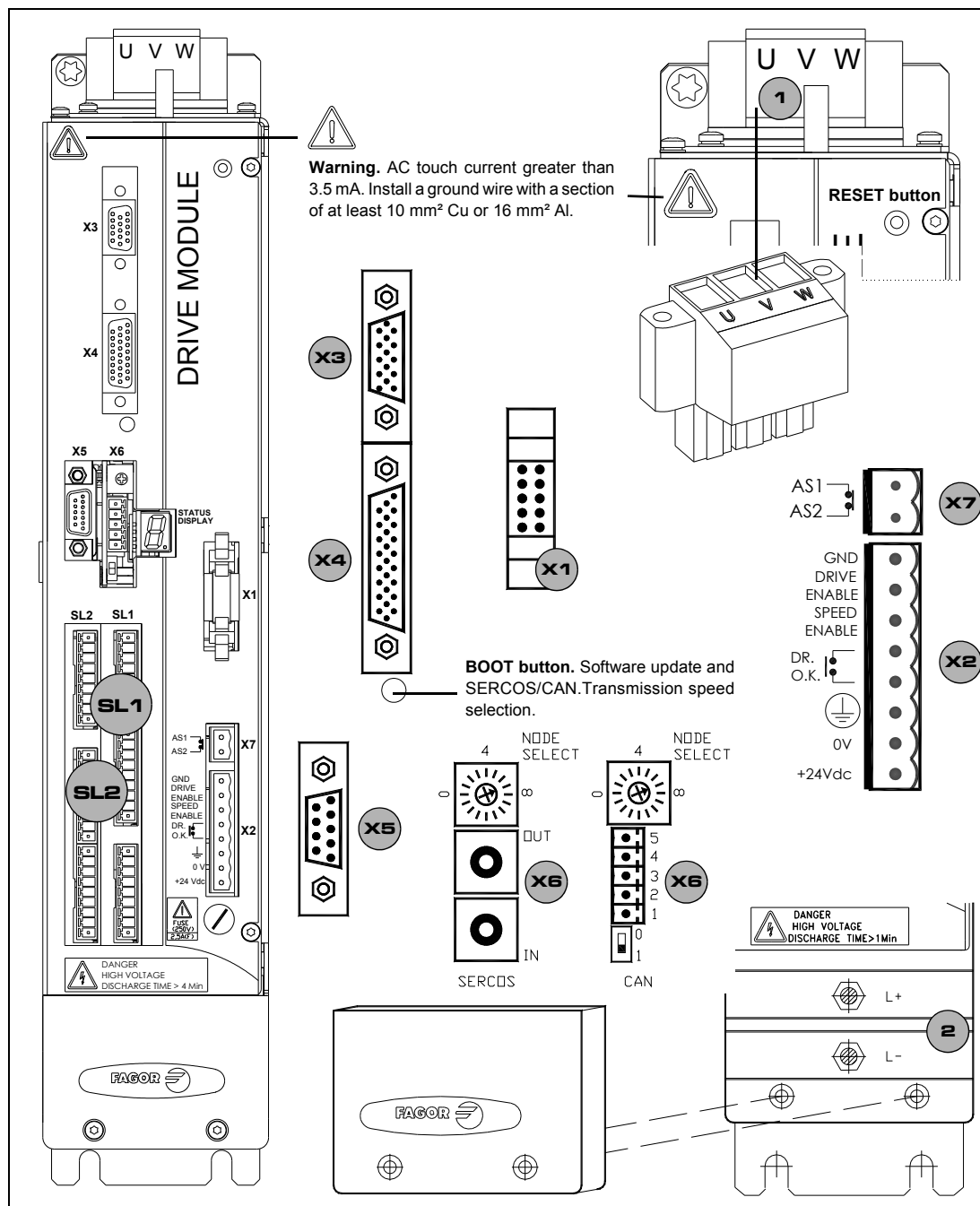

**F. H3/49**

Connectors of "AXD/SPD 1.35" modular drives.

- 1. Power connector for motor connection.
- 2. Power bus that feeds the drive modules from the power supply through metal plates.
- X1. Connector that may be used to establish communication between modules through the internal bus.
- X2. Connector for the basic control signals.
- X3. Connector with two possible uses:
  - as output of the encoder simulator.
  - as input of the direct feedback for the position loop.
- X4. Connector for motor feedback connection (encoder).
- X5. Connector for RS-232 serial line connection.
- X6. SERCOS or CAN interface connector.
- X7. Connector for external acknowledgment of the status of the safety relay.
- SL1. Slot for the cards A1, 16DI-8DO and 8DI-16DO.
- SL2. Slot for the cards 16DI-8DO and 8DI-16DO.

**3.**  
**DRIVE MODULES**  
 Modular drives



**DDS  
 HARDWARE**

**Ref.1310**

**AXD/SPD 2.50/2.75, SPD 2.85**

These drive modules have the following connectors:

**3.**  
**DRIVE MODULES**  
Modular drives

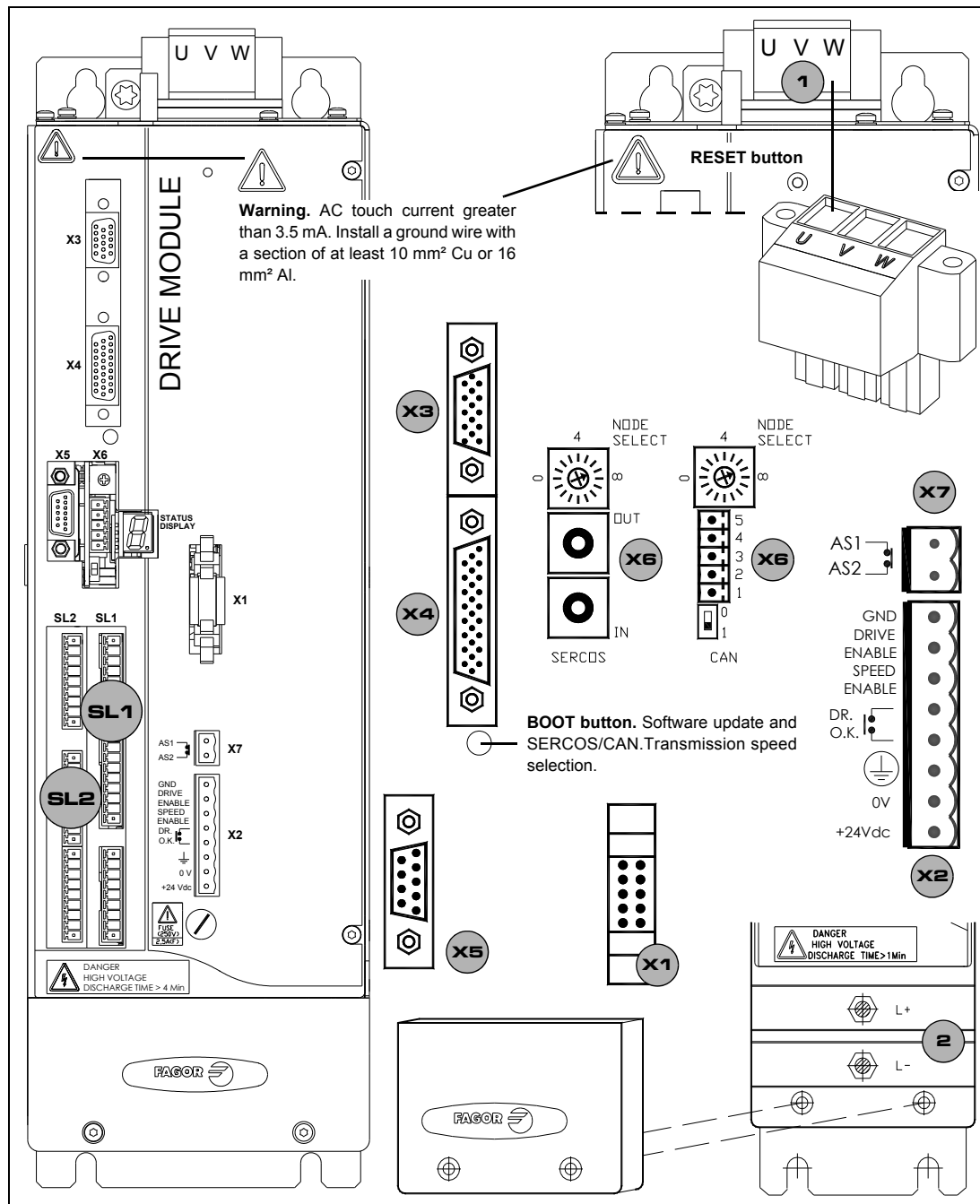

**F. H3/50**

Connectors of "AXD/SPD 2.50/2.75, SPD 2.85" modular drives.

- 1. Power connector for motor connection.
- 2. Power bus that feeds the drive modules from the power supply through metal plates.
- X1. Connector that may be used to establish communication between modules through the internal bus.
- X2. Connector for the basic control signals.
- X3. Connector with two possible uses:
  - as output of the encoder simulator.
  - as input of the direct feedback for the position loop.
- X4. Connector for motor feedback connection (encoder).
- X5. Connector for RS-232 serial line connection.
- X6. SERCOS or CAN interface connector.
- X7. Connector for external acknowledgment of the status of the safety relay.
- SL1. Slot for the cards A1, 16DI-8DO and 8DI-16DO.
- SL2. Slot for the cards 16DI-8DO and 8DI-16DO.



**DDS  
HARDWARE**

Ref.1310

### AXD/SPD 3.100/3.150

These drive modules have the following connectors:

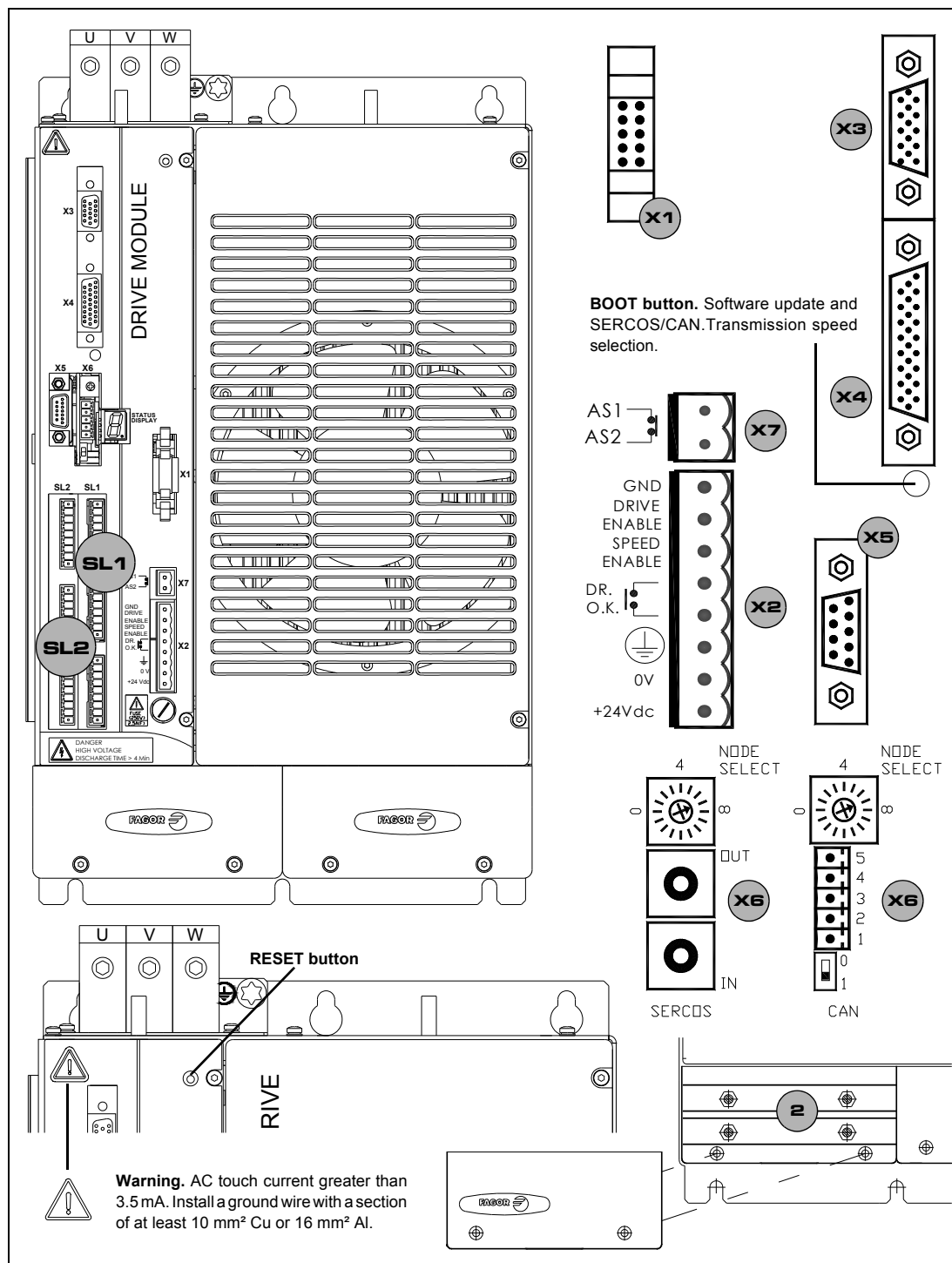

# 3.

**DRIVE MODULES**  
Modular drives

**BOOT button.** Software update and SERCOS/CAN. Transmission speed selection.

#### F. H3/51

Connectors of "AXD/SPD 3.100/3.150" modular drives.

1. Power connector for motor connection.
2. Power Bus that can supply power to the drive modules through metal plates.
- X1. Connector that may be used to establish communication between modules through the internal bus.
- X2. Connector for the basic control signals.
- X3. Connector with two possible uses:
  - as output of the encoder simulator.
  - as input of the direct feedback for the position loop.
- X4. Connector for motor feedback connection (encoder).
- X5. Connector for RS-232 serial line connection.
- X6. SERCOS or CAN interface connector.
- X7. Connector for external acknowledgment of the status of the safety relay.
- SL1. Slot for the cards A1, 16DI-8DO and 8DI-16DO.
- SL2. Slot for the cards 16DI-8DO and 8DI-16DO.



**DDS  
HARDWARE**

Ref.1310

**SPD 3.200/3.250**

This drive module has the following connectors:

**3.**

**DRIVE MODULES**  
Modular drives

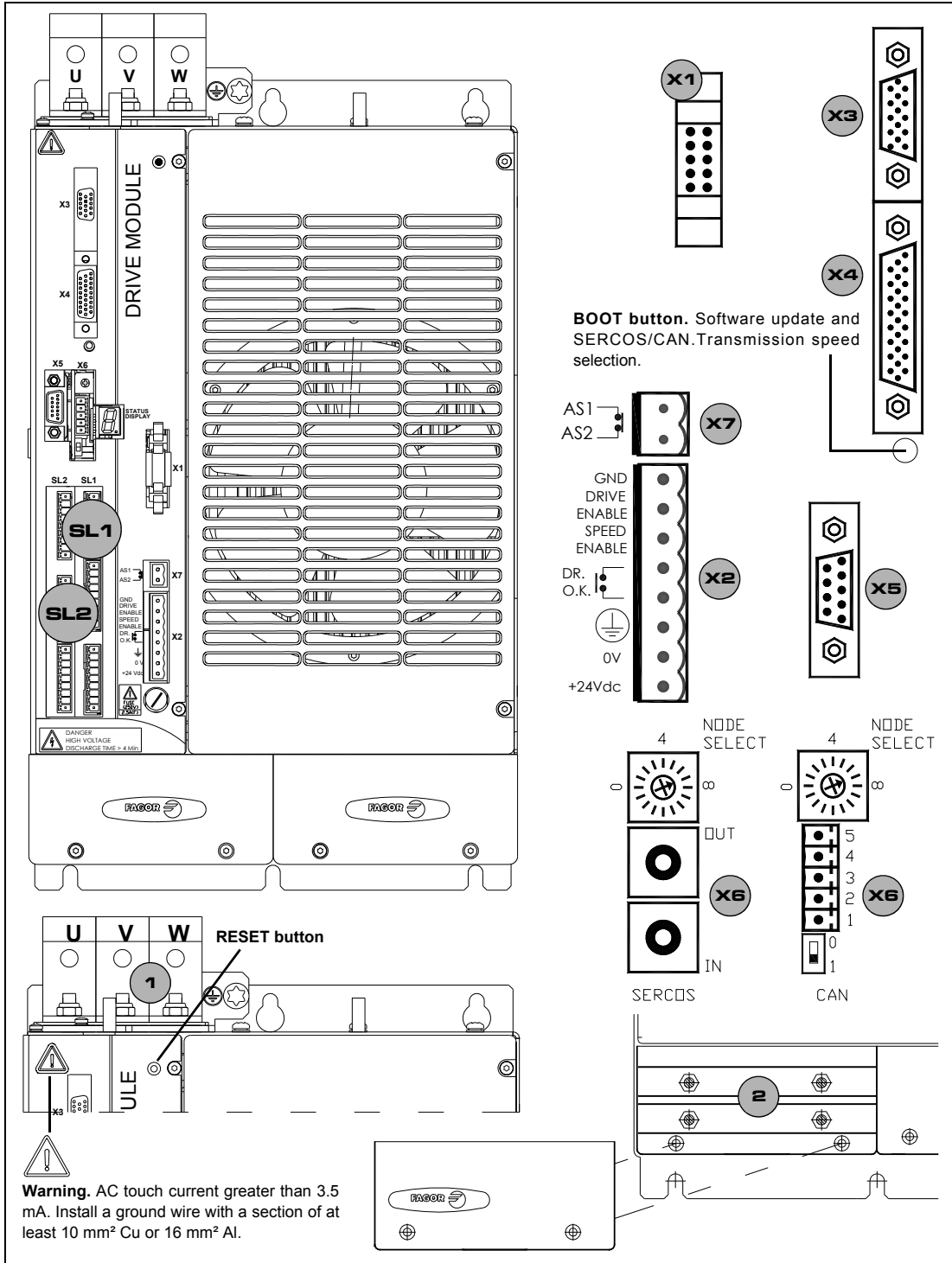

**F. H3/52**

Connectors of "SPD 3.200/3.250" modular drives.

- 1. Power connector for motor connection.
- 2. Power Bus that can supply power to the drive modules through metal plates.
- X1. Connector that may be used to establish communication between modules through the internal bus.
- X2. Connector for the basic control signals.
- X3. Connector with two possible uses:
  - as output of the encoder simulator.
  - as input of the direct feedback for the position loop.
- X4. Connector for motor feedback connection (encoder).
- X5. Connector for RS-232 serial line connection.
- X6. SERCOS or CAN interface connector.
- X7. Connector for external acknowledgment of the status of the safety relay.
- SL1. Slot for the cards A1, 16DI-8DO and 8DI-16DO.
- SL2. Slot for the cards 16DI-8DO and 8DI-16DO.



DDS  
HARDWARE

Ref.1310

**MMC 1.08/1.15**

These drive modules have the following connectors:

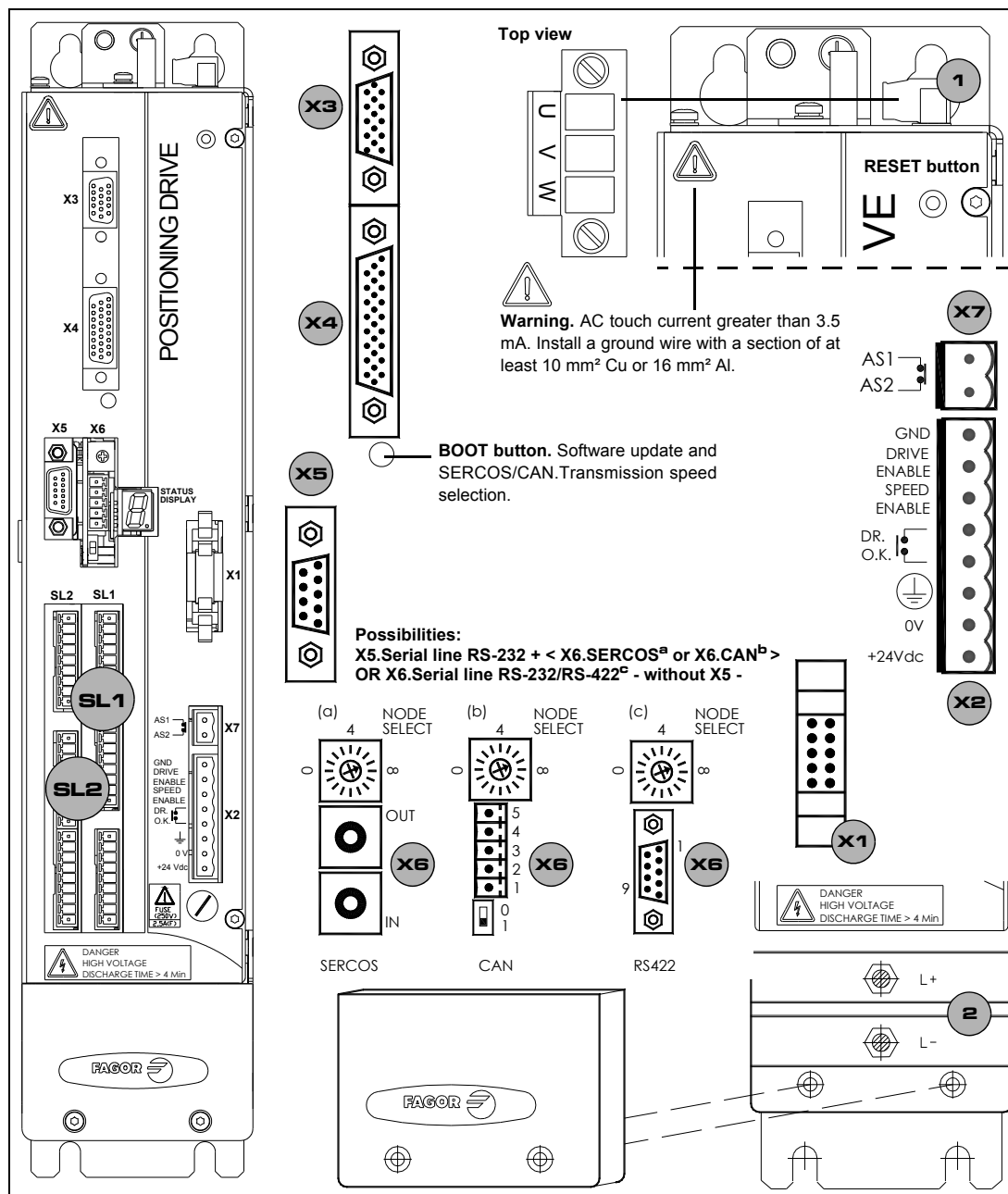

**3.**  
**DRIVE MODULES**  
 Modular drives

**F. H3/53**

Connectors of “MMC 1.08/1.15” modular drives.

1. Power connector for motor connection.
2. Power bus that feeds the drive modules from the power supply through metal plates.
- X1. Connector that may be used to establish communication between modules through the internal bus.
- X2. Connector for the basic control signals.
- X3. Connector with two possible uses:
  - as output of the encoder simulator.
  - as input of the direct feedback for the position loop.
- X4. Connector for motor feedback connection (encoder).
- X5. Connector for RS-232 serial line connection.
- X6. Possible connectors that may be located in this position:
  - SERCOS<sup>a</sup> or CAN<sup>b</sup> interface connector (always with X5)
  - Connector for RS-232/RS-422<sup>c</sup> serial line connection (never with X5)
- X7. Connector for external acknowledgment of the status of the safety relay.
- SL1. Slot for the cards A1, 16DI-8DO and 8DI-16DO.
- SL2. Slot for the cards 16DI-8DO and 8DI-16DO.



**DDS  
 HARDWARE**

**Ref.1310**

**MMC 1.25**

These drive modules have the following connectors:

**3.**  
**DRIVE MODULES**  
Modular drives

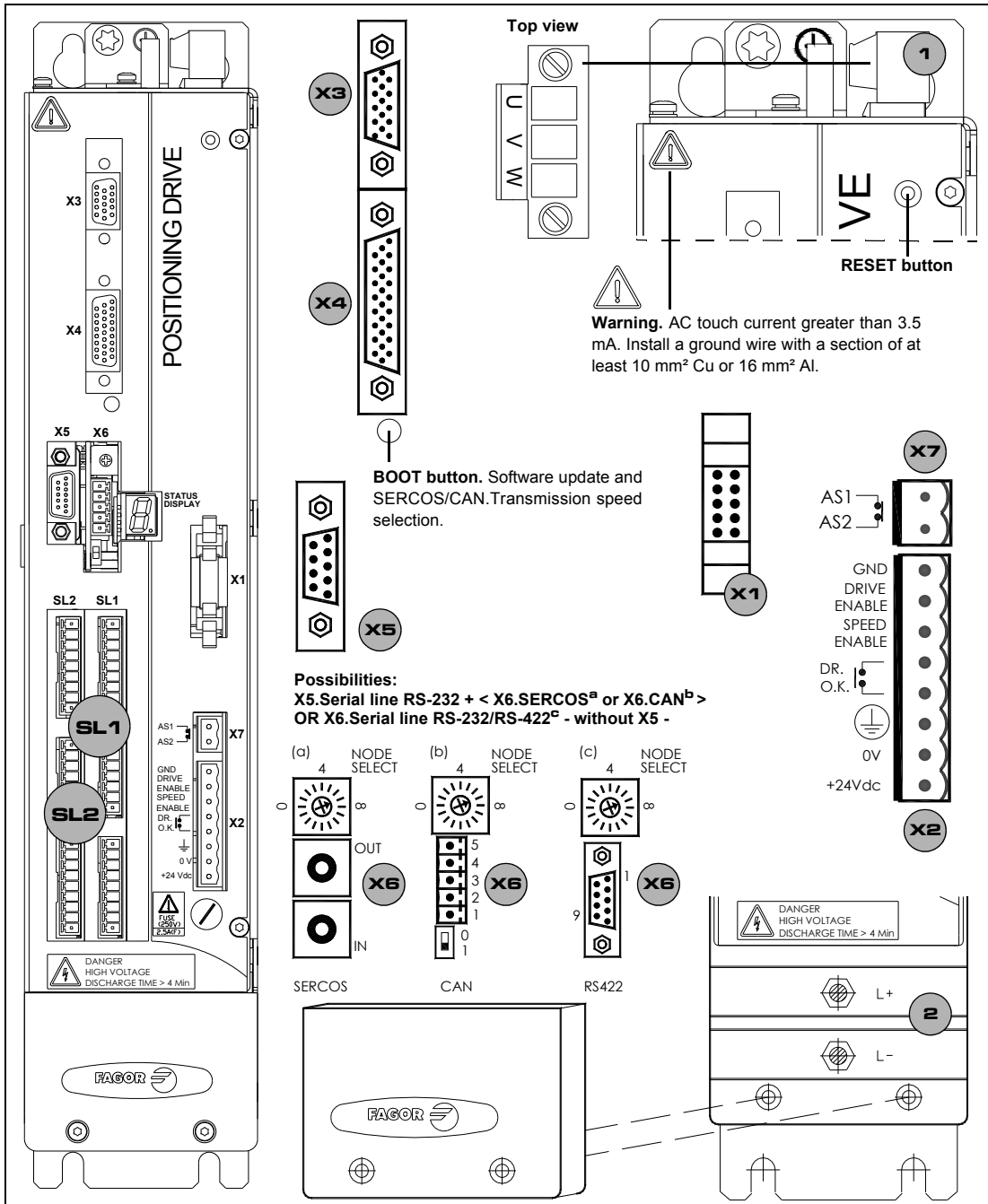

**F. H3/54**

Connectors of "MMC 1.25" modular drives.

1. Power connector for motor connection.
2. Power bus that feeds the drive modules from the power supply through metal plates.
- X1. Connector that may be used to establish communication between modules through the internal bus.
- X2. Connector for the basic control signals.
- X3. Connector with two possible uses:
  - as output of the encoder simulator.
  - as input of the direct feedback for the position loop.
- X4. Connector for motor feedback connection (encoder).
- X5. Connector for RS-232 serial line connection.
- X6. Possible connectors that may be located in this position:
  - SERCOS<sup>a</sup> or CAN<sup>b</sup> interface connector (always with X5)
  - Connector for RS-232/RS-422<sup>c</sup> serial line connection (never with X5)
- X7. Connector for external acknowledgment of the status of the safety relay.
- SL1. Slot for the cards A1, 16DI-8DO and 8DI-16DO.
- SL2. Slot for the cards 16DI-8DO and 8DI-16DO.



**DDS  
HARDWARE**

**Ref.1310**

### MMC 1.35

These drive modules have the following connectors:

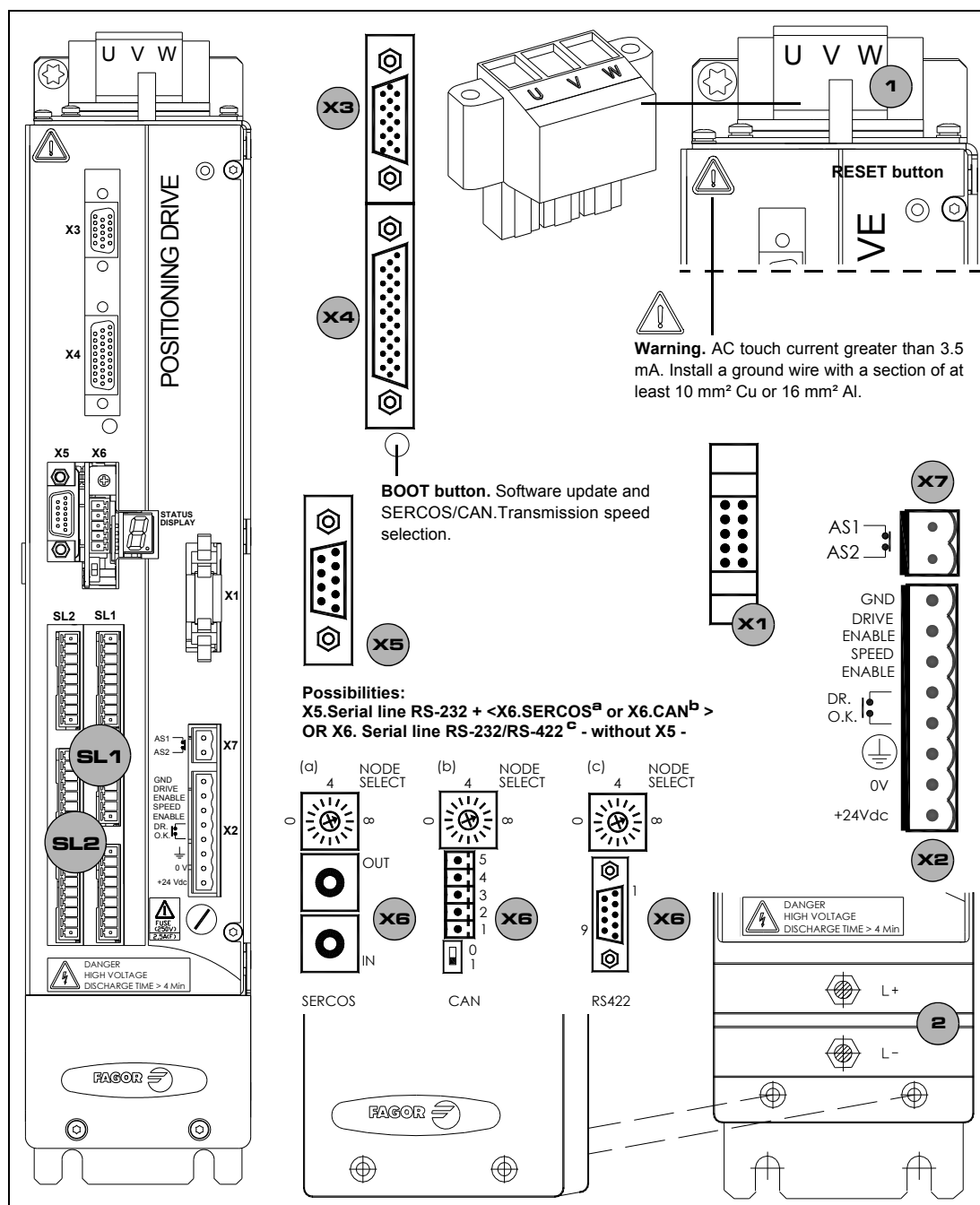

# 3.

**DRIVE MODULES**  
Modular drives

#### F. H3/55

Connectors of "MMC 1.35" modular drives.

1. Power connector for motor connection.
2. Power bus that feeds the drive modules from the power supply through metal plates.
- X1. Connector that may be used to establish communication between modules through the internal bus.
- X2. Connector for the basic control signals.
- X3. Connector with two possible uses:
  - as output of the encoder simulator.
  - as input of the direct feedback for the position loop.
- X4. Connector for motor feedback connection (encoder).
- X5. Connector for RS-232 serial line connection.
- X6. Possible connectors that may be located in this position:
  - SERCOS<sup>a</sup> or CAN<sup>b</sup> interface connector (always with X5)
  - Connector for RS-232/RS-422<sup>c</sup> serial line connection (never with X5)
- X7. Connector for external acknowledgment of the status of the safety relay.
- SL1. Slot for the cards A1, 16DI-8DO and 8DI-16DO.
- SL2. Slot for the cards 16DI-8DO and 8DI-16DO.



**DDS  
HARDWARE**

Ref.1310

**MMC 2.50/2.75**

These drive modules have the following connectors:

**3.**  
**DRIVE MODULES**  
Modular drives

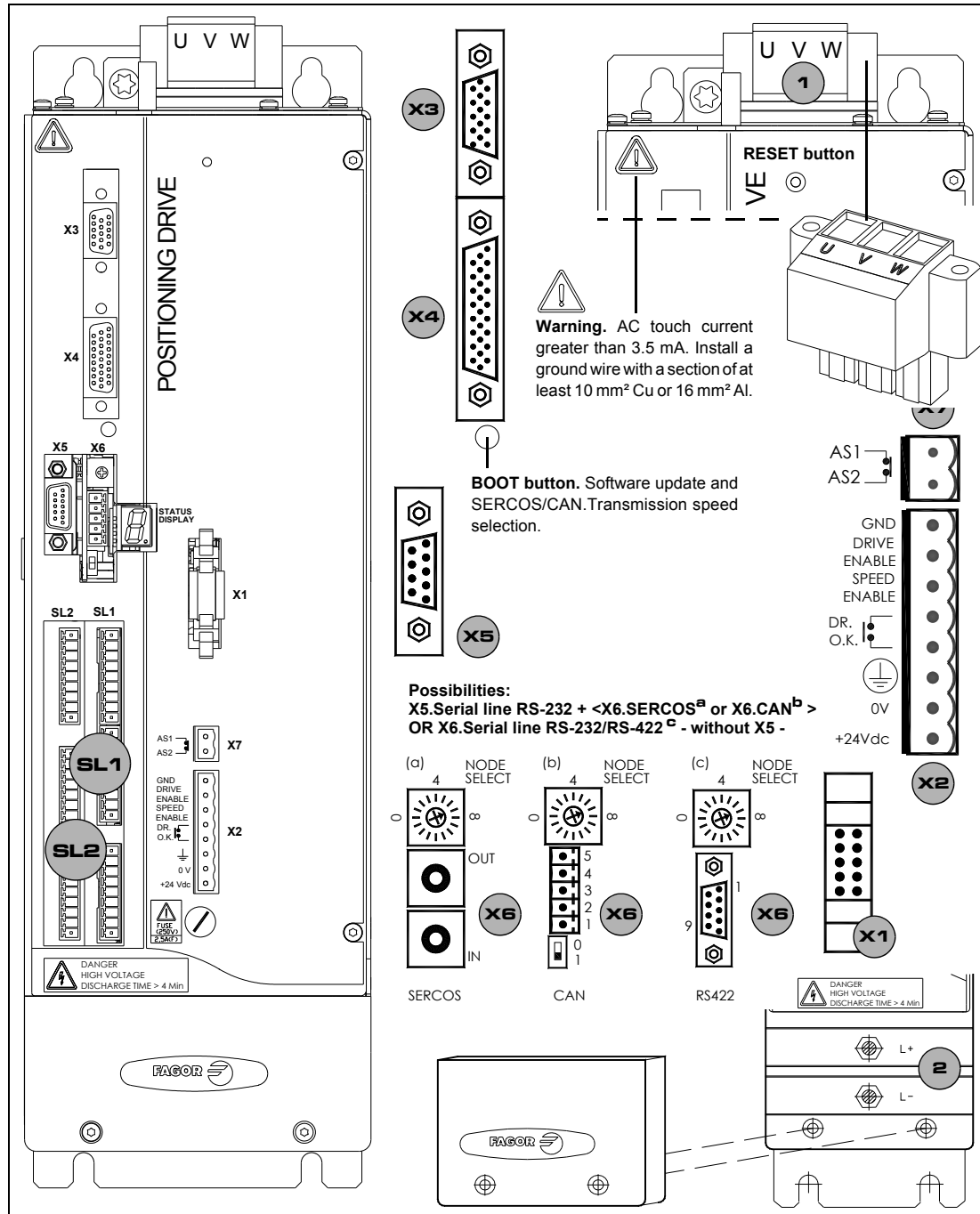

**F. H3/56**

Connectors of "MMC 2.50/2.75" modular drives.

1. Power connector for motor connection.
2. Power bus that feeds the drive modules from the power supply through metal plates.
- X1. Connector that may be used to establish communication between modules through the internal bus.
- X2. Connector for the basic control signals.
- X3. Connector with two possible uses:
  - as output of the encoder simulator.
  - as input of the direct feedback for the position loop.
- X4. Connector for motor feedback connection (encoder).
- X5. Connector for RS-232 serial line connection.
- X6. Possible connectors that may be located in this position:
  - SERCOS<sup>a</sup> or CAN<sup>b</sup> interface connector (always with X5)
  - Connector for RS-232/RS-422<sup>c</sup> serial line connection (never with X5)
- X7. Connector for external acknowledgment of the status of the safety relay.
- SL1. Slot for the cards A1, 16DI-8DO and 8DI-16DO.
- SL2. Slot for the cards 16DI-8DO and 8DI-16DO.



**DDS  
HARDWARE**

**Ref.1310**

**MMC 3.100/3.150**

These drive modules have the following connectors:

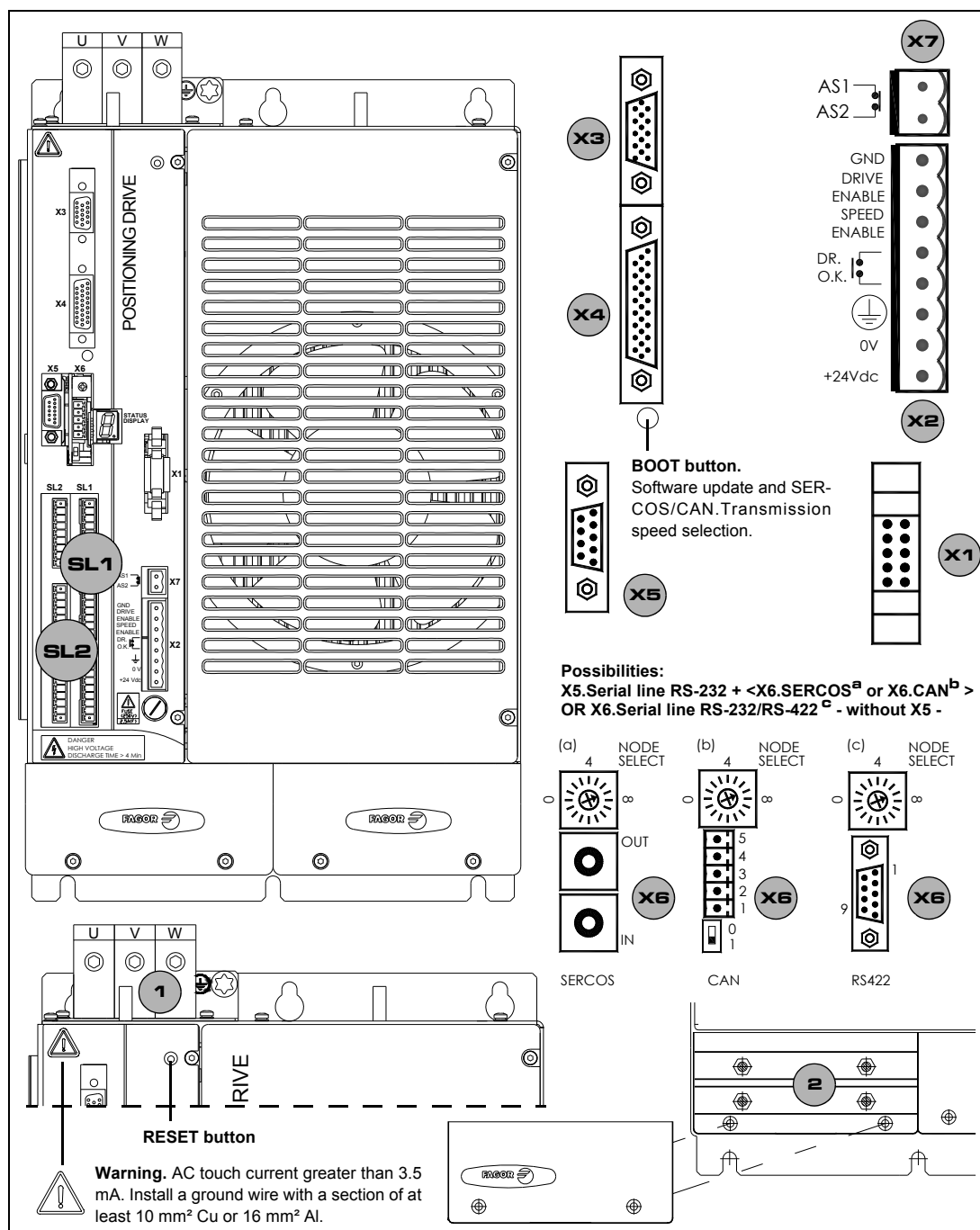

**3.**  
DRIVE MODULES  
Modular drives

**F. H3/57**

Connectors of "MMC 3.100/3.150" modular drives.

1. Power connector for motor connection.
2. Power bus that feeds the drive modules from the power supply through metal plates.
- X1. Connector that may be used to establish communication between modules through the internal bus.
- X2. Connector for the basic control signals.
- X3. Connector with two possible uses:
  - as output of the encoder simulator.
  - as input of the direct feedback for the position loop.
- X4. Connector for motor feedback connection (encoder).
- X5. Connector for RS-232 serial line connection.
- X6. Possible connectors that may be located in this position:
  - SERCOS<sup>a</sup> or CAN<sup>b</sup> interface connector (always with X5)
  - Connector for RS-232/RS-422<sup>c</sup> serial line connection (never with X5)
- X7. Connector for external acknowledgment of the status of the safety relay.
- SL1. Slot for the cards A1, 16DI-8DO and 8DI-16DO.
- SL2. Slot for the cards 16DI-8DO and 8DI-16DO.



DDS  
HARDWARE

Ref.1310

**MMC 3.200/3.250**

These drive modules have the following connectors:

**3.**  
**DRIVE MODULES**  
Modular drives

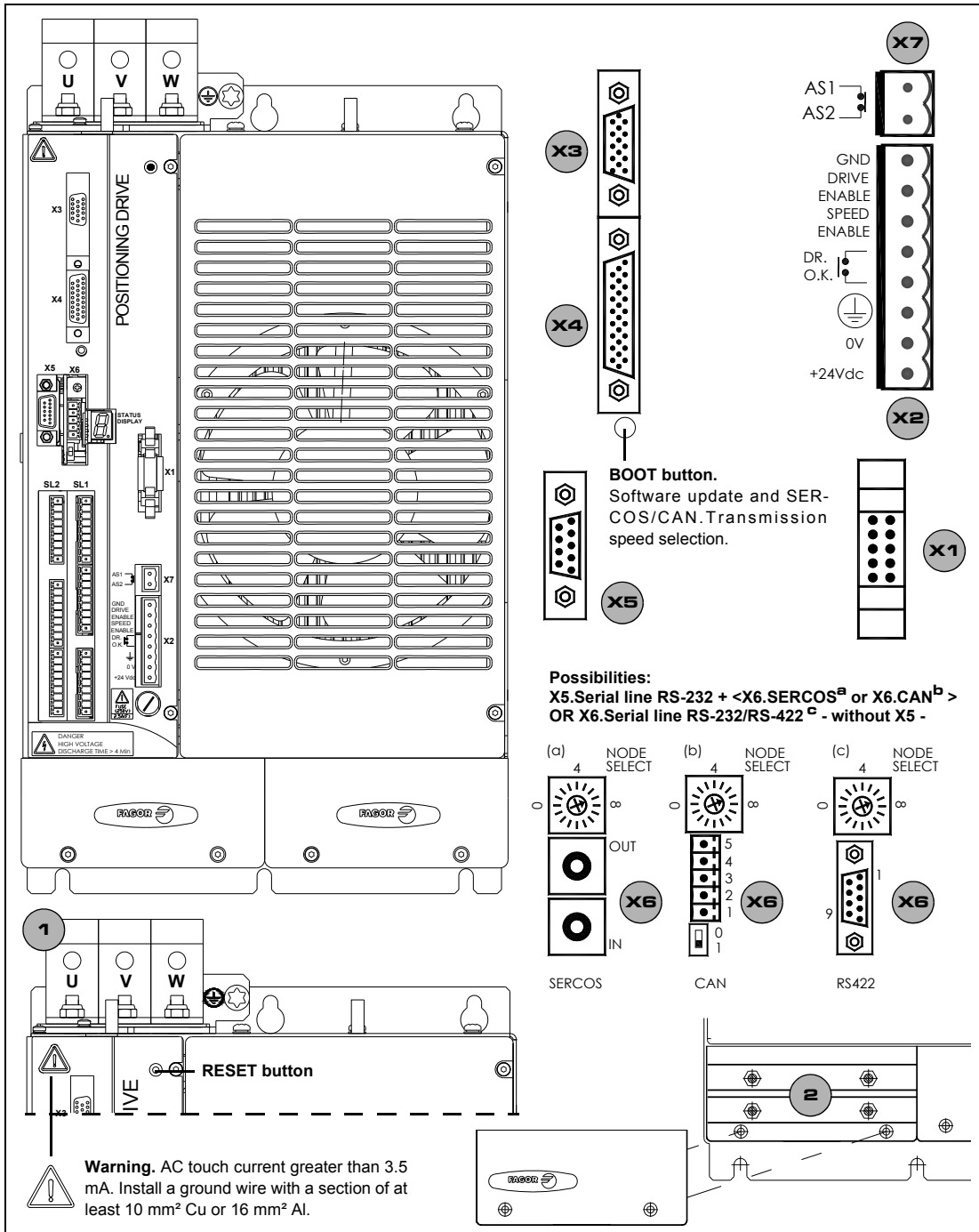

**F. H3/58**

Connectors of "MMC 3.200/3.250" modular drives.

1. Power connector for motor connection.
2. Power bus that feeds the drive modules from the power supply through metal plates.
- X1. Connector that may be used to establish communication between modules through the internal bus.
- X2. Connector for the basic control signals.
- X3. Connector with two possible uses:
  - as output of the encoder simulator.
  - as input of the direct feedback for the position loop.
- X4. Connector for motor feedback connection (encoder).
- X5. Connector for RS-232 serial line connection.
- X6. Possible connectors that may be located in this position:
  - SERCOS<sup>a</sup> or CAN<sup>b</sup> interface connector (always with X5)
  - Connector for RS-232/RS-422<sup>c</sup> serial line connection (never with X5)
- X7. Connector for external acknowledgment of the status of the safety relay.
- SL1. Slot for the cards A1, 16DI-8DO and 8DI-16DO.
- SL2. Slot for the cards 16DI-8DO and 8DI-16DO.



DDS  
HARDWARE

Ref.1310

## Other elements

Besides the various connectors, the front panel of the drive has other elements that are mentioned next.

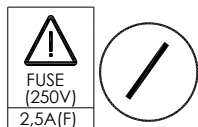

### Fuse

The fuse on the front panel of each modular drive is a “2.5 A (F)/250 V (fast)” fuse and it is used to protect the internal control circuits.

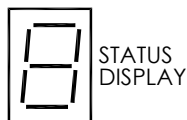

### Status display

The seven-segment status display shows the information on the drive module status or the corresponding code when an error or warning occurs - see the section “turning a drive on” at the end of this chapter - . It can also display the transmission speed when setting it both with SERCOS or CAN interface.

# 3.

**DRIVE MODULES**  
Modular drives

**FAGOR** 

**DDS  
HARDWARE**

**Ref.1310**

# 3.

DRIVE MODULES  
Modular drives

## Function of the connectors

### Power connector

The power connectors located on top of each drive module are used to connect the motor.

The ground connection of the cable shields is made from the vertical plate next to the connectors.

The power bus input is located at the bottom of the modules and under the screwed-on lid. The drive needs 456-800 V DC which can vary depending on the mains voltage and the load. The power supply module is in charge supplying this voltage.

2 plates are supplied with each module for this connection and another one for connecting the chassis with each other.

The following table shows the values for gap, tightening torque, pole sections (wire entry holes) and other data regarding these screw-on connectors according to drive model:

**T. H3/6** Technical data of the terminals of the power connector.

AXD/SPD/MMC	1.08 1.15	1.25	1.35	2.50 2.75	2.85	3.100 3.150	3.200 3.250
<b>Connector data</b>							
Gap (mm)	7.62	7.62	10.16	10.16	10.16	-	-
Min/max tightening torque (Nm)	0.5/0.6	0.7/0.8	1.2/1.5	1.7/1.8	1.7/1.8	6/8	15/20
Screw thread	M3	M3	M4	M4	M4	M6	M8
Min./max. section (mm <sup>2</sup> )	0.2/4	0.2/6	0.75/6	0.75/16	0.75/16	16/50	35/95
Rated current I <sub>n</sub> (A)	20	41	41	76	76	150	232
<b>Wire data</b>							
Length to strip (mm)	7	10	12	12	12	24	27



**WARNING.** When connecting the drive module with its corresponding motor connect terminal U of the drive module with the terminal corresponding to the U phase of the motor. Proceed the same way to connect the terminals V-V, W-W and PE-PE. If they are not connected like this, it could perform poorly. The cable must have a metallic shield that must be connected to the ground terminal of the drive and to that of the motor in order to comply with EU directives.



**WARNING.** Observe that before handling these terminals, you must proceed as indicated and in the following order:

- Disconnect the mains voltage at the electrical cabinet.
- Wait a few minutes before handling these terminals.

The power supply needs time to decrease the voltage of the power bus down to safe values (< 42 V DC). The green indicator DC BUS ON being turned OFF does not mean that the power bus may be handled or manipulated. The discharge time depends on the number of elements connected and it is about 4 minutes.



**WARNING.** Please note that the STO (**S**afe **T**orque **O**ff) safety function does not imply an electrical power off. There is still voltage at the DC bus. Ignoring this warning may cause electric shock.



DDS  
HARDWARE

Ref.1310

**X1 connector**

This connector may be used to connect the modules to each other through the internal bus communicating the elements of the servo drive system with each other.

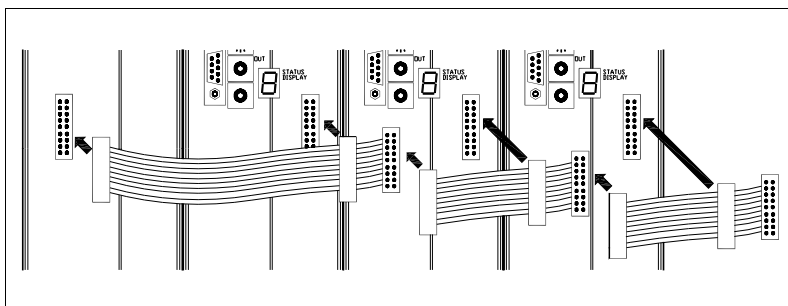

**F. H3/59**

Connector X1. Internal Bus.

All the modules powered with the same power supply must be connected to this bus and this condition is must to run it.

Together with each module, a connector and a ribbon cable are supplied for this connection.



**WARNING.** This bus must never be disconnected while the system is running.

**X2 connector**

It is an 8-pin connector of the modular drive.

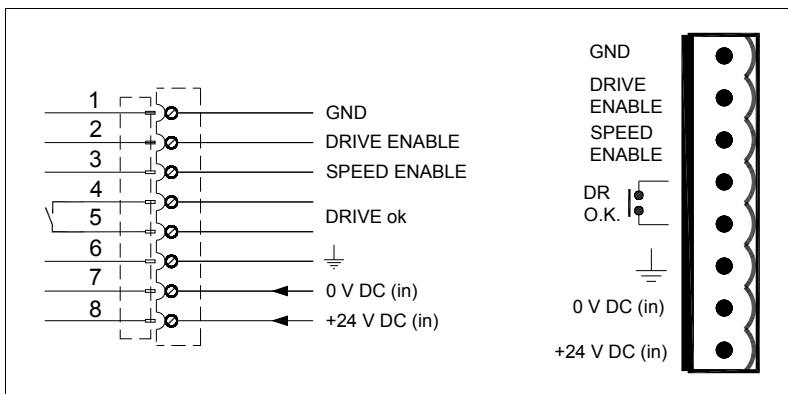

**F. H3/60**

Connector X2. Control.

When the control circuit is supplied with 24 V DC (pins 7 and 8) the drive runs an internal test.

If the module is ok, it closes the module status Drive OK contacts (pins 4 and 5). This contact stays closed while the modular drive is supplied with 24 V DC and it runs properly.

To govern a motor, the drives also needs energy at the power bus.

The maximum internal consumption of the + 24 V DC supply input is 2 A (for the bigger drives).

A 2.5 A fuse protects the internal circuits.

With the "Drive Enable" and "Speed Enable" inputs (pins 2 and 3) together with the velocity command, it is possible to govern the motor. The consumption of these control signals is between 4.5 and 7 mA.

**3.**

**DRIVE MODULES**  
Modular drives



**DDS  
HARDWARE**

**Ref.1310**

**3.**  
**DRIVE MODULES**  
Modular drives

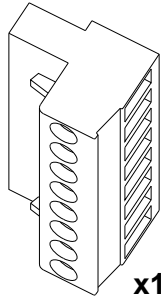

The following table shows the values for gap, tightening torque, sections and other data of the plug-in connector for X2.

**T. H3/7** Characteristics of the pins of connector X2.

<b>AXD/SPD/MMC</b>	<b>1.08</b>	<b>2.50</b>	<b>3.100</b>
	<b>1.15</b>	<b>2.75</b>	<b>3.150</b>
	<b>1.25</b>	<b>2.85</b>	<b>3.200</b>
	<b>1.35</b>		<b>3.250</b>
<b>Connector data</b>			
Nr of poles	8	8	8
Gap (mm)	5	5	5
Min/max tightening torque (Nm)	0.5/0.6	0.5/0.6	0.5/0.6
Screw thread	M3	M3	M3
Min./max. section (mm <sup>2</sup> )	0.2/2.5	0.2/2.5	0.2/2.5
Rated current I <sub>n</sub> (A)	12	12	12
<b>Wire data</b>			
Length to strip (mm)	7	7	7

The description of the pins of this connector is:

**T. H3/8** Signals at the pins of connector X2 of the modular drive.

1	GND	Control signals	Reference 0 V for control signals
2	Drive Enable		Motor current enable (24 V DC)
3	Speed Enable		Drive speed enable (24 V DC)
4	Drive OK	Contact indicating module status (it opens in case of failure). Limit 1 A at 24 V DC.	
5	Drive OK		
6	Chassis	Chassis connection.	
7	0 V DC (IN)	Supply input for the control circuit	Reference 0 V
8	+24 V DC (IN)		Positive voltage input (21÷28 V DC)

**SPEED ENABLE AND DRIVE ENABLE**

**Normal operating mode**

1. Activate the Drive Enable and Speed Enable inputs (24 V DC) in the desired order. Before activating, the Soft Start process ( smoothly reaching the power bus voltage ) must be over. The motor will have torque only when Drive Enable is active and there is voltage at the power bus. The motor speed will be controlled with a command when the Speed Enable function is active.



**INFORMATION.** Activating the Drive Enable function requires to be requested by the system in three different ways. They are: Electrical signal at connector X2, variable BV7 (F00203), and variable DRENA of the PLC when using the SERCOS or CAN interface. It could be deactivated through any of them. Only via connector X2 is certified. See chapter 9. **FUNCTIONAL SAFETY.**

2. The motor will respond to all analog command variations only while both inputs (Drive Enable and Speed Enable) are at 24 V DC. If any of them is deactivated, the following will happen. See the operation modes in figure F. H3/61.

**Deactivation of the Drive Enable input**

The Drive Enable input lets the current circulate through the motor stator windings. When it is powered with 24 V DC the current is enabled and the drive can work.

If the Drive Enable input drops to 0 V DC (no voltage), the power circuit is off and the motor will have not torque, hence not being governed and will turn freely until it stops by friction.



DDS  
HARDWARE

Ref.1310

### Deactivation of the Speed Enable input

When the Speed Enable input is set to 0 V DC, the internal velocity command follows the stop ramp set by parameter and:

#### □ Situation 1

The torque is kept active by braking the motor. When it stops, variable SV5 (S00331) is activated. The motor has stopped in a time period shorter than the one indicated by parameter GP3 (F00702). The torque is canceled and the rotor is free.

#### □ Situation 2

The torque is kept active by braking the motor. When it stops, variable SV5 (S00331) is activated. The motor does not stop in a time period set by parameter GP3 (F00702). The motor stops when its kinetic energy runs out.

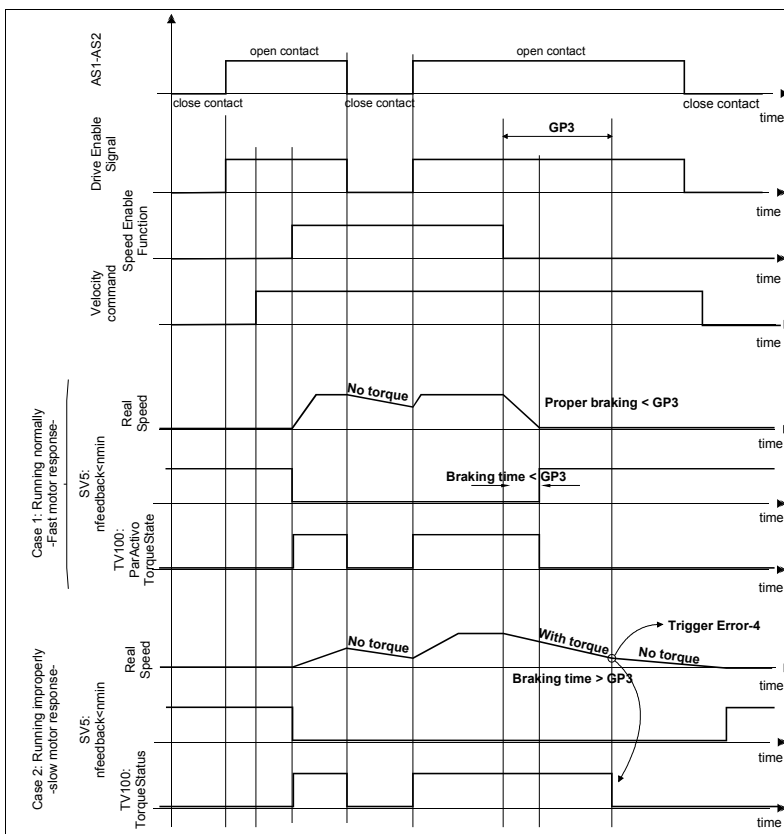

#### F. H3/61

Operating modes of functions Drive Enable and Speed Enable.

**NOTE.** Also see in chapter 2 (**X2 connector**, pin 5 on PS power supplies), (**X2 connector**, pin 5 on XPS power supplies) or (**X6 connector**, pin 5 on RPS power supplies) corresponding to the System Speed Enable input and its effect on the Speed Enable inputs of modular drives.

See also the internal parameter GP3 (F00702) and the internal variable SV5 (S00331) in chapter 13 of the “man\_dds\_soft.pdf” manual that is supplied with this one.



**WARNING.** AXD/SPD drives (see **DECLARATION OF CONFORMITY** section) have the Drive Enable input as one channel of **STO (Safe Torque OFF)** safety function (PL d or SIL 2). Main contactor - KM1 may be used for another channel. See chapter 9. **FUNCTIONAL SAFETY** in this manual.



**WARNING.** In case of mains failure, the control circuit and its signals must maintain their 24 V DC while the motors are braking.

On modular drives, the 24 V DC needed to activate the Drive Enable must be obtained from a power supply that maintains its rated value during that period of time. The PS-25B4 power supply, the APS-24 auxiliary power supply and the regenerative XPS and RPS power supplies meet this condition.



DDS  
HARDWARE

Ref.1310

**3.**

**DRIVE MODULES**  
Modular drives

**X3 connector**

This connector of the modular drive offers two possible configurations:

- Encoder simulator
- Direct feedback

**X3. Encoder simulator**

Having installed the encoder simulator card, X3 is a high density (HD) 15-pin sub-D type male (M) connector whose pins are galvanically isolated from the rest of the drive.

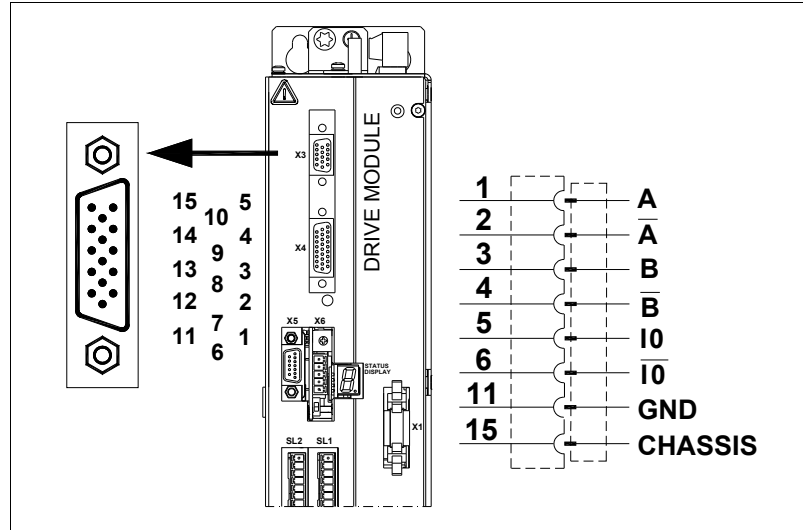

**F. H3/62**

Connector X3. Pinout.

It outputs square differential TTL pulses simulating those of an encoder that would be mounted on the motor shaft.

The number of pulses per turn and the position of the reference mark I0 are programmable.

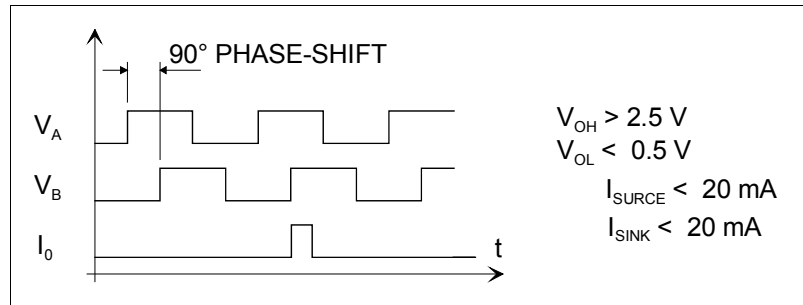

**F. H3/63**

Connector X3. Pulses per revolution and reference mark position.



DDS  
HARDWARE

Ref.1310

### X3. Direct feedback

Having installed a direct feedback card, X3 is a high density (HD) 15-pin sub-D type female (F) connector.

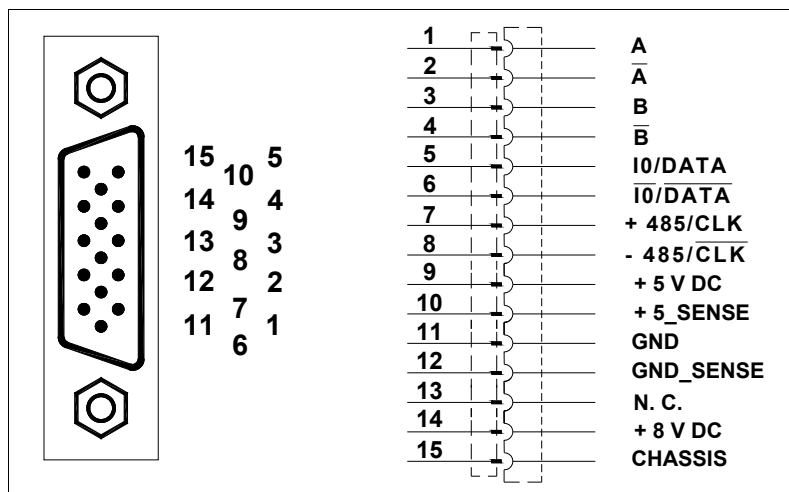

#### F. H3/64

Connector X3. Pinout.

It supports the following signals:

- Square single-ended TTL
- Square differential (double-ended) TTL
- 1 Volt peak-to-peak sinusoidal (1 Vpp)
- SSI
- EnDat

and the following frequencies:

- 1 MHz with square signals
- 500 kHz with sinusoidal signals

The input impedance for sinusoidal signals is 120 Ω.



DDS  
HARDWARE

Ref.1310

# 3.

**DRIVE MODULES**  
Modular drives

## With external incremental feedback device

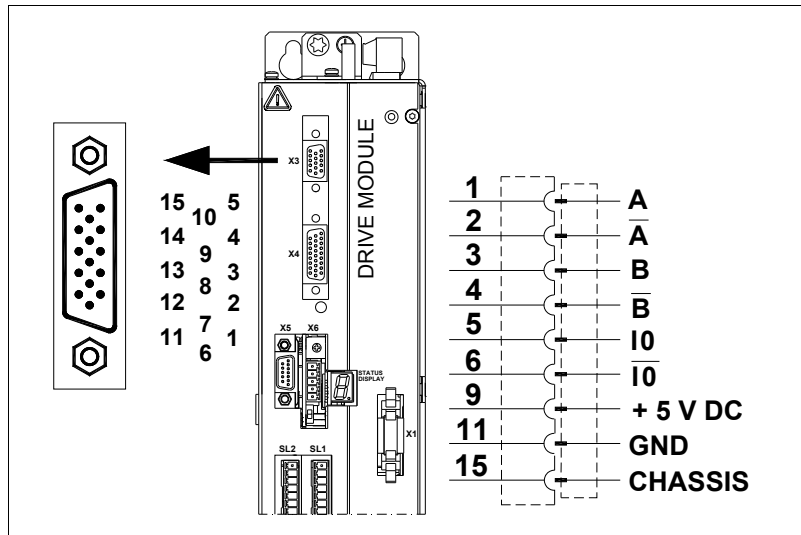

**F. H3/65**

Connector X3. Signals sent by an external incremental feedback device.

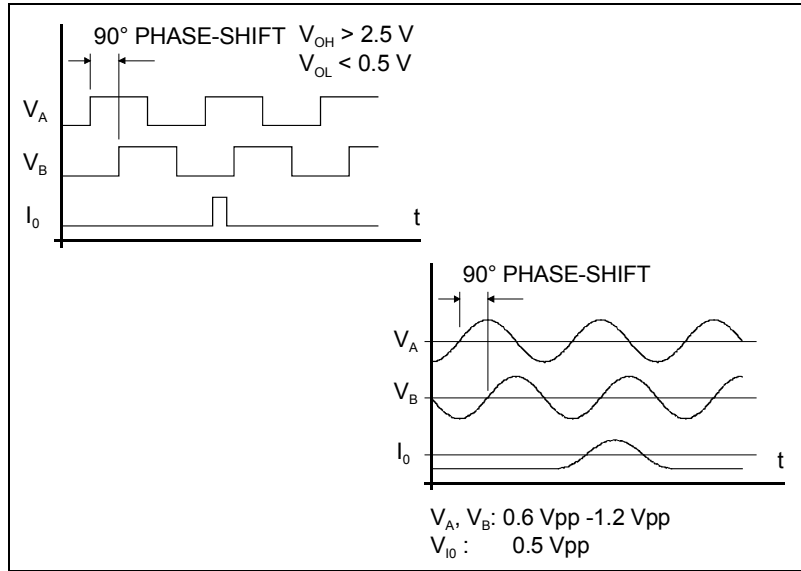

**F. H3/66**

Characteristics of the square TTL signals and 1Vpp sinusoidal signals.

## With external absolute feedback device

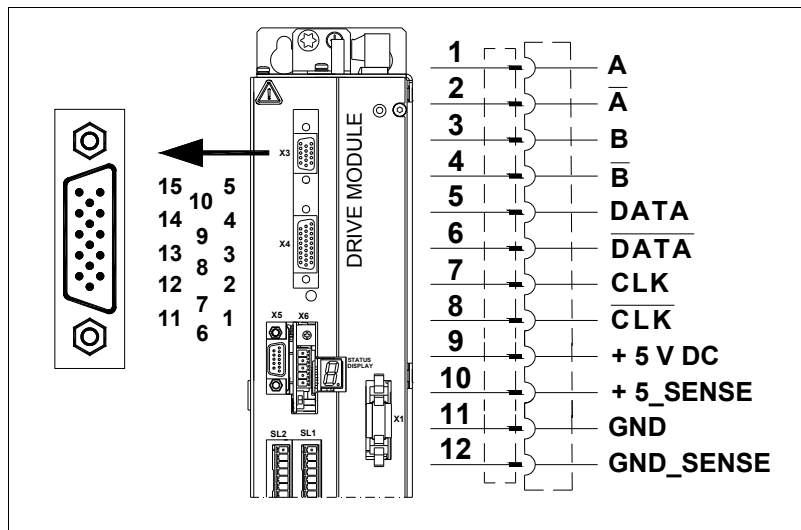

**F. H3/67**

Connector X3. Signals sent by an external absolute feedback device.



DDS  
HARDWARE

Ref.1310

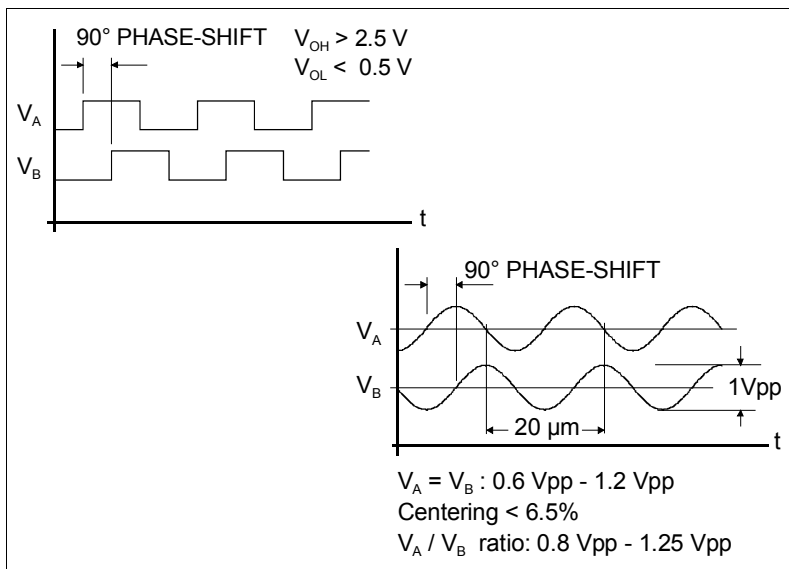

**F. H3/68**

Characteristics of the square TTL signals and 1 Vpp sinusoidal signals.

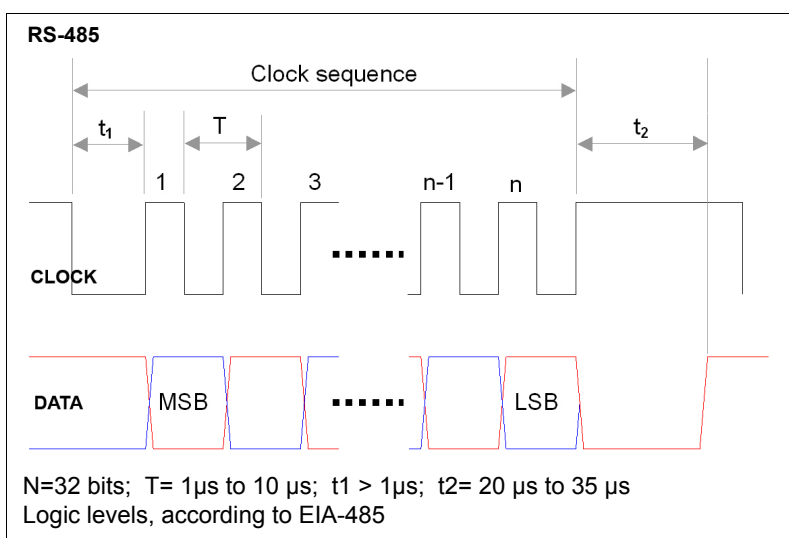

**F. H3/69**

Characteristics of the SSI signals.

**3.**  
 DRIVE MODULES  
 Modular drives



DDS  
 HARDWARE

Ref.1310

**3.**

**DRIVE MODULES**  
Modular drives

**X4 connector**

**X4. Motor feedback**

Is the connector for the motor feedback board that may come on modular drives. It is a high density (HD) 26-pin sub-D type female connector. Through it, the board receives the signals coming from the feedback device attached to the motor shaft.

The pinout of connector X4 depending on whether the motor feedback board installed at the drive is a CAPMOTOR-1 or a CAPMOTOR-2 is:

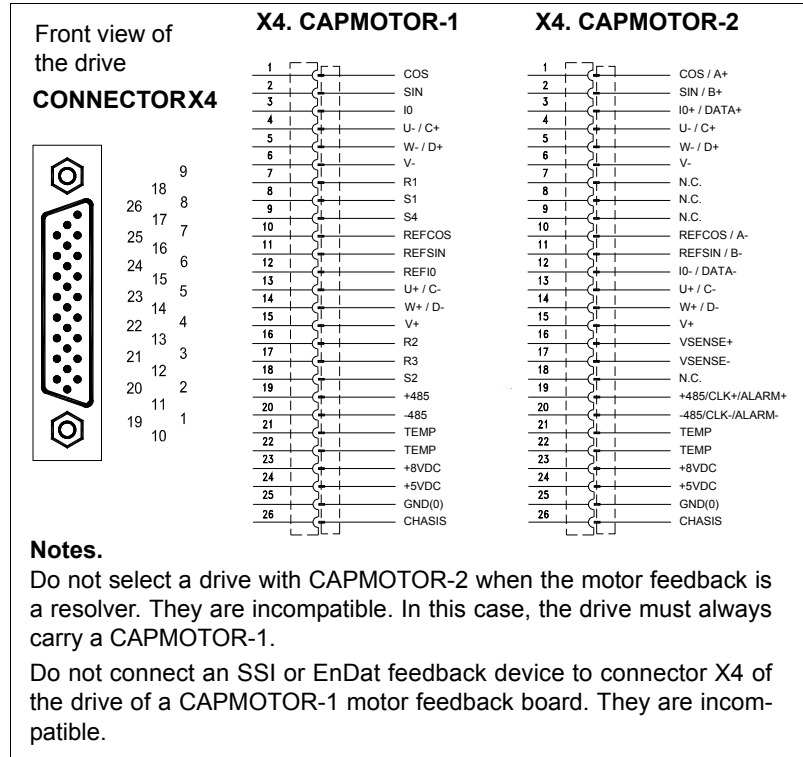

**F. H3/70**

Connector X4. Feedback on the motor. CAPMOTOR-1 or CAPMOTOR-2.

**NOTE.** To know whether your drive has a CAPMOTOR-2 installed, check the label on the side of the drive and see if the last field of the sales reference is a B. If not, it will have a CAPMOTOR-1.

The feedback of FAGOR motors use sinusoidal encoder, incremental TTL encoder or resolver. Refer to the corresponding motor manual for the detailed description of the pinout of the feedback devices that can go with each motor family.

With CAPMOTOR-2, this connector admits signals:

- Square TTL
- 1 Volt peak-to-peak sinusoidal (1 Vpp)
- SSI
- EnDat

with the following working frequencies:

- 1 MHz with square signals
- 500 kHz with sinusoidal signals

The input impedance for sinusoidal signals is 120 Ω.

The characteristics of the signals are the same as the ones described in the previous chapter for the incremental and absolute feedback devices. See figures F. H3/65, F. H3/66, F. H3/67, F. H3/68 and F. H3/69.



**DDS  
HARDWARE**

Ref.1310

**X5 connector**

**X5. RS-232 serial line**

This connector of the RS-232 serial line board that may be included in a modular drive is a 9-pin male sub-D connector for RS-232 serial connection to a PC in order to set the module configuration parameters and to adjust it.

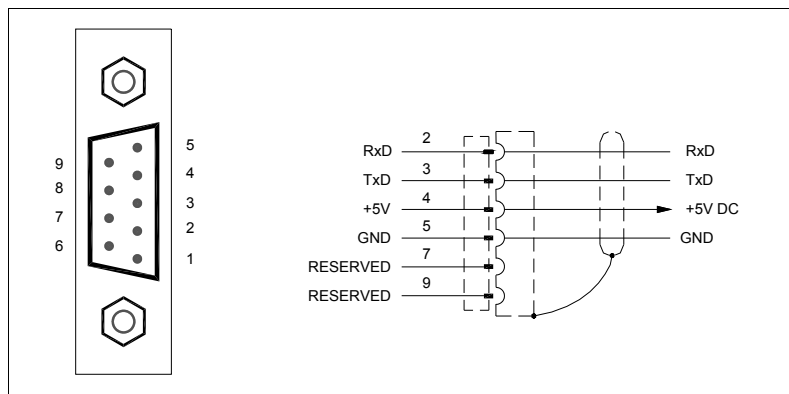

**F. H3/71**

Connector X5. RS-232 serial line.

The description of the pins of this connector is:

**T. H3/9** Description of the pins of connector X5.

(\*) Reserved pins must not be connected.

<b>1</b>	N. C.	Not connected
<b>2</b>	R x D	Receive data
<b>3</b>	T x D	Transmit data
<b>4</b>	+ 5 V	Supply outputs
<b>5</b>	GND	Reference 0 V
<b>6</b>	N. C.	Not connected
<b>7</b>		(*) Reserved
<b>8</b>	N. C.	Not connected
<b>9</b>		(*) Reserved
<b>CH</b>	CHASSIS	Cable shield



DDS  
HARDWARE

Ref.1310

# 3.

**DRIVE MODULES**  
Modular drives

## X6 connector

This connector of the modular drive identified as X6 may be:

- A SERCOS interface connector.
- A CAN interface connector.
- An RS-232/422 serial line connector (only on MMC drives).

### X6. SERCOS

This connector consists of a SERCOS signal receiver and emitter (Honeywell IN, OUT) and may be used to connect the modules of the DDS system with the CNC that governs them. The connection is made through fiber optic lines and it has a ring structure.

It will always come with a node selecting rotary switch (NODE SELECT) that lets identify each drive within the system.

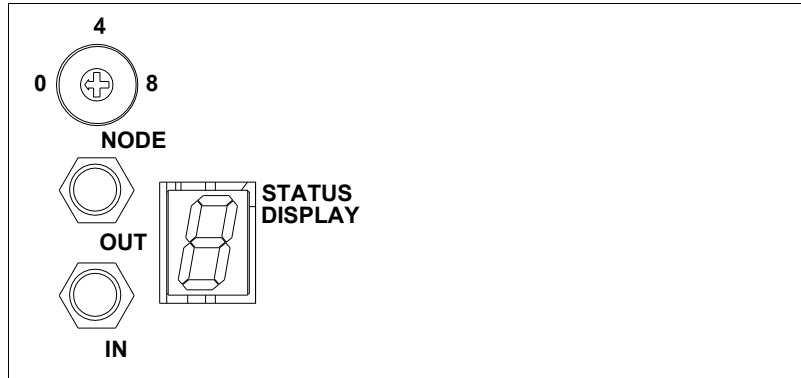

**F. H3/72**

Honeywell emitter-receiver for SERCOS transmission.



**INFORMATION.** Note that on modular “AXD, SPD and MMC” drives, this connector will always come with connector X5.

### X6. CAN

5-pin female connector where only three pins are connected CANL (2), SHIELD (3) and CANH (4) and may be used to connect the module of the DDS system with the CNC or another master element (ESA panel) that governs them.

The connection is made with a CAN cable and it has a field bus network type structure. It will always come with a node selecting rotary switch (NODE SELECT) that lets identify each drive within the system.

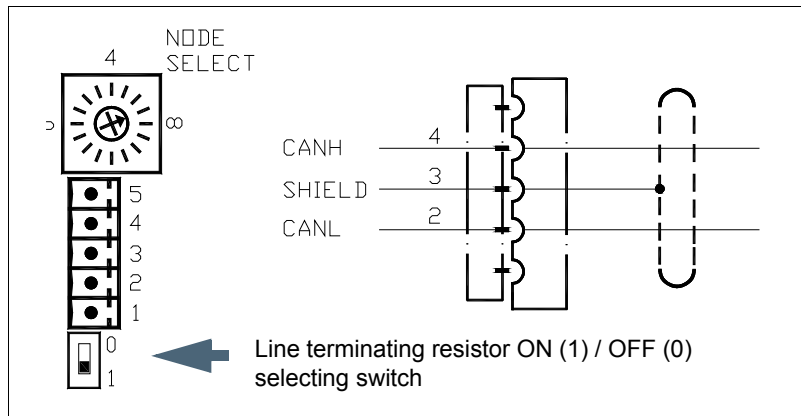

**F. H3/73**

CAN interface connector.



DDS  
HARDWARE

Ref.1310

The description of the pinout of this connector is:

**T. H3/10** Description of the pinout of connector X6 (CAN interface).

1	GNDa	N.C. (not connected)
2	CANL	CAN L bus line
3	SHIELD	Overall shield
4	CANH	CAN H bus line
5	SHIELD	N.C. (not connected)



Note that on modular drives AXD, SPD and MMC, this connector will always come with connector X5.

**3.**

DRIVE MODULES  
Modular drives

**X6. RS-232/422 serial line connector**

**NOTE.** Only MMC modular drives can have this connector.

It is a 9-pin male sub-D connector for connecting an RS-232/422 serial line with a device acting as master. This device is usually a PC or an ESA video terminal (VT).

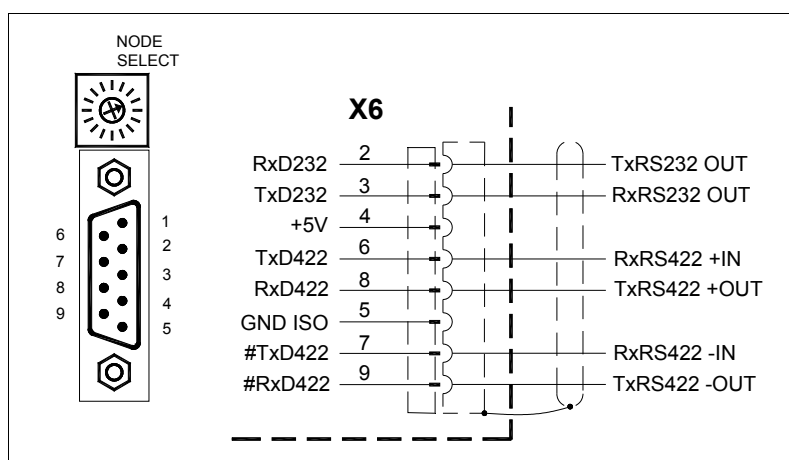

**F. H3/74**

RS-232/422 serial line connector.



**INFORMATION.** Note that on modular drives, only the MMC models can have the RS-232/422 connector and only when they do not have the connector X5.

The description of the pins of this connector is:

**T. H3/11** Description of the pins of the RS-232/422 connector.

1	N. C.	Not connected
2	R x D 232	RS-232 serial line data reception
3	T x D 232	RS-232 serial line data transmission
4	+ 5 V ISO	Supply outputs
5	GND ISO	Reference 0 V
6	T x D 422	RS-422 serial line data transmission
7	#T x D 422	
8	R x D 422	RS-422 serial line data reception
9	#R x D 422	
CH	CHASSIS	Cable shield



DDS  
HARDWARE

Ref.1310

**3.**

**DRIVE MODULES**  
Modular drives

**X7 connector**

**X7. Status of the integrated-safety relay**

This connector X7 of the modular drive is associated with the second contact (N.C., **N**ormally **C**losed) of an internal safety relay (with guided contacts). The status of the relay (initially closed) may be acknowledged through the two pins and a CNC, PLC or control panel, i.e. that the integrated safety relay has actually opened or closed. These two terminals are identified at the drive as AS1-AS2. The opening or closing of this relay depends on whether 24 V DC are present or not at pin 2 <DRIVE ENABLE> of control connector X2. For further detail on this connector, see section **9.2. Interface** of chapter **9. FUNCTIONAL SAFETY** in this manual.

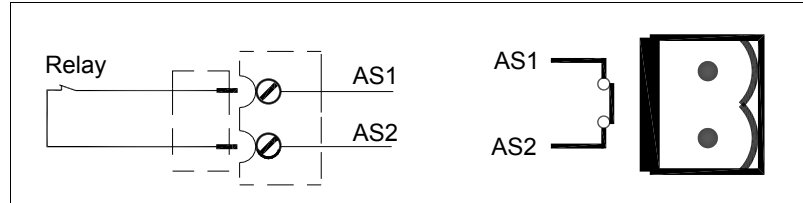

**F. H3/75**

Connector X7. External acknowledgment of the status of the integrated safety relay.

The following table shows the values for gap, tightening torque, sections and other data of aerial plug-in connector X7:

**T. H3/12** Characteristics of the pins of connector X7.

AXD/SPD/MMC	1.08	2.50	3.100
	1.15	2.75	3.150
	1.25	2.85	3.200
	1.35		3.250
Connector data			
Nr of poles	2	2	2
Gap (mm)	5	5	5
Min/max tightening torque (Nm)	0.5/0.6	0.5/0.6	0.5/0.6
Screw thread	M3	M3	M3
Min./max. section (mm <sup>2</sup> )	0.2/2.5	0.2/2.5	0.2/2.5
Rated current I <sub>n</sub> (A)	12	12	12
Wire data			
Length to strip (mm)	7	7	7

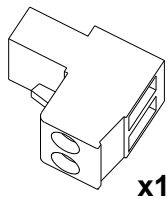

DDS  
HARDWARE

Ref.1310

**Connectors at slots SL1 and SL2**

**CARD A1**

The A1 card must always be in slot SL1.

**X6-DIGITAL I/Os, digital inputs and outputs**

It offers 4 digital inputs and 4 digital outputs, all of them fully programmable.

The digital inputs are optocoupled and referred to a common point (pin 5). The digital outputs are contact type and also optocoupled.

Each input and output is associated with a parameter. The user may assign to these parameters, internal Boolean type variables that may be used to show the system status via electrical contacts. See "man\_dds\_soft.pdf" manual.

These assigned Boolean variables are set with the monitor program for PC (WinDDSSetup).

**3.**

**DRIVE MODULES**  
Modular drives

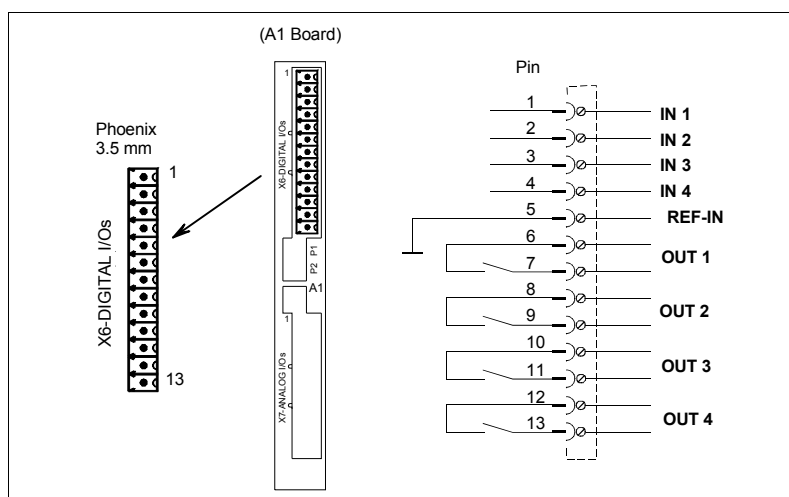

**F. H3/76**

A1 card: X6-DIGITAL I/Os. Digital inputs and outputs.

**Digital inputs characteristics**

Maximum rated voltage	24 V DC (36 V DC)
ON/OFF voltage	18 V DC (5 V DC)
Maximum typical consumption	5 mA (7 mA)

**Digital outputs characteristics**

Maximum voltage	250 V
Maximum load current (peak)	150 mA (500 mA)
Maximum internal resistance	24 Ω
Galvanic isolation voltage	3750 V (1 min)



**DDS  
HARDWARE**

**Ref.1310**

# 3.

**DRIVE MODULES**  
Modular drives

## X7-ANALOG I/Os, digital inputs and outputs

It offers 2 inputs and 2 outputs, all of them fully programmable. Each input and output is associated with a parameter. See “man\_dds\_soft.pdf” manual. It offers a ± 15 V power supply for generating a command easily.

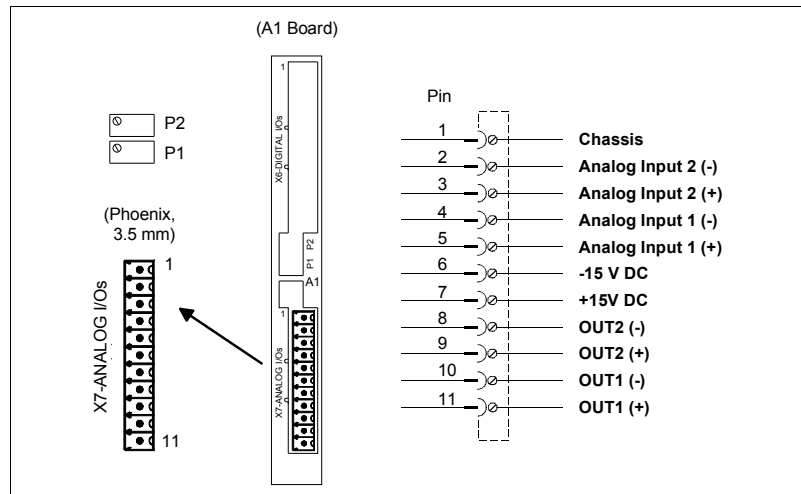

### F. H3/77

A1 card: X7- ANALOG I/Os. Analog inputs and outputs.

### Pinout

**T. H3/13** Description of the pins of connector X7-ANALOG I/O. Analog inputs and outputs.

1	Chassis
2	Analog input 2 ( - )
3	Analog input 2 ( + )
4	Analog input 1 ( - )
5	Analog input 1 ( + )
6	Adjustment output (-15 V DC) (user)
7	Adjustment output (+15 V DC) (user)
8	Reference for analog output 2 ( - )
9	Analog output 2 ( + )
10	Reference for analog output 1 ( - )
11	Analog output 1 ( + )

### Analog input 1

Associated with pins 4 and 5. It is the usual input for the velocity command (± 10 V DC) generated by the CNC.

### Analog input 2

Associated with pins 2 and 3. It is the auxiliary command input.

### Analog input characteristics

Resolution	1.22 mV	
Input voltage range	±10 V DC	
Input over-voltage	Continuous mode	80 V DC
	Transients	250 V DC
Input impedance	With respect to GND	40 kΩ
	Between both inputs	80 kΩ
Voltage in common mode	20 V DC	



DDS  
HARDWARE

Ref.1310

Dip-Switches (DS1, DS2)

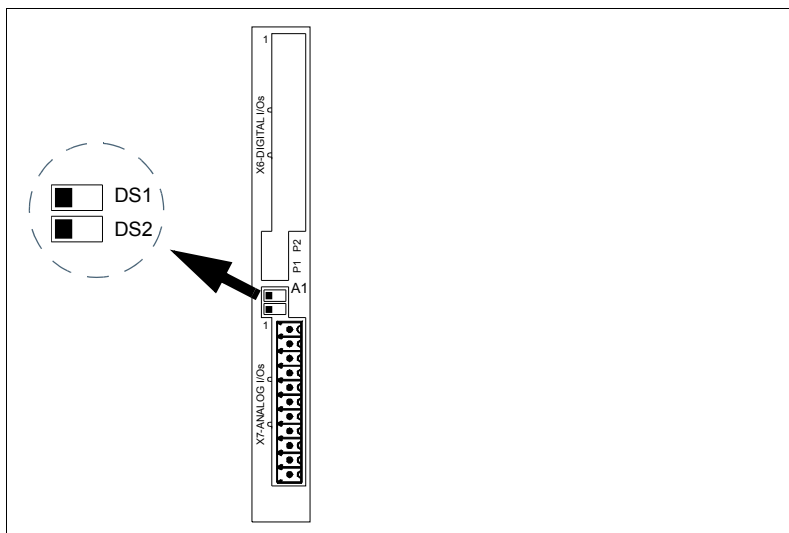

F. H3/78

Factory settings of the dip-switches (DS1, DS2).



**MANDATORY.** The status of the dip-switches (DS1, DS2) must not be changed by the operator.

Adjustment outputs

With these outputs and a potentiometer, the user can obtain a variable analog voltage for adjusting the servo system during setup.

The voltage, with no load, at these pins is  $\pm 15$  V DC.

The electrical circuit necessary to obtain a reference voltage and the recommended resistance values to obtain an approximate range of  $\pm 10$  V DC for the Vref are described next:

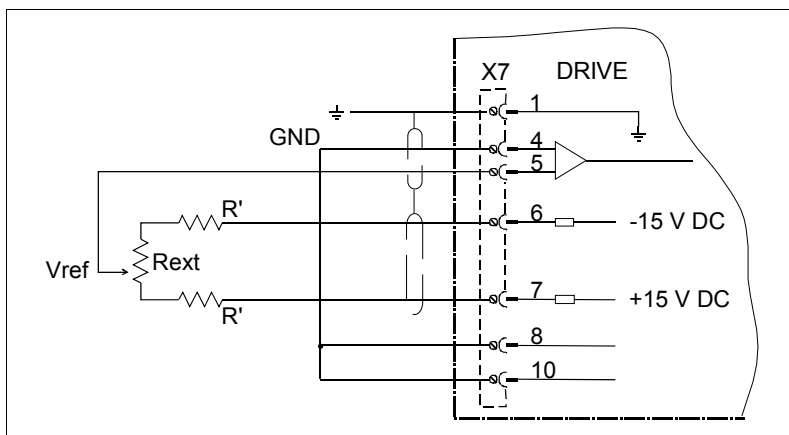

F. H3/79

Adjustment outputs.

Range $\pm 10$ V	
Rext.	R'
1 k $\Omega$	0 $\Omega$
5 k $\Omega$	820 $\Omega$
10 k $\Omega$	1.8 k $\Omega$
20 k $\Omega$	3.3 k $\Omega$

**3.**  
DRIVE MODULES  
Modular drives



DDS  
HARDWARE

Ref.1310

**Analog outputs**

Associated with pins 8-9 and 10-11. These outputs provide an analog voltage indicating the status of the internal system variables. They are especially designed as permanent monitoring of these internal variables and also to be connected to an oscilloscope to make it easier to set the system up.



**INFORMATION.** Note that if the output current is high, the voltage range may decrease.

**Analog output characteristics**

Resolution	4.88 mV
Voltage range	±10 V DC
Maximum current	±15 mA
Impedance (respect to GND)	112 Ω

**3.**  
**DRIVE MODULES**  
 Modular drives



DDS  
HARDWARE

Ref.1310

### CARDS 8DI-16DO and 16DI-8DO

These cards may be located in slot SL1 and/or SL2.

- 8DI-16DO offers to the user 8 digital inputs and 16 outputs
- 16DI-8DO offers to the user 16 digital inputs and 8 outputs

#### X8-DIG.INs, X11-DIG.INs, X12-DIG.INs, digital inputs

They offer 8 fully programmable digital inputs.

The digital inputs are optocoupled and referred to a common point (pin 1) and they admit digital signals at 24 V DC.

Each input is associated with a PLC resource.

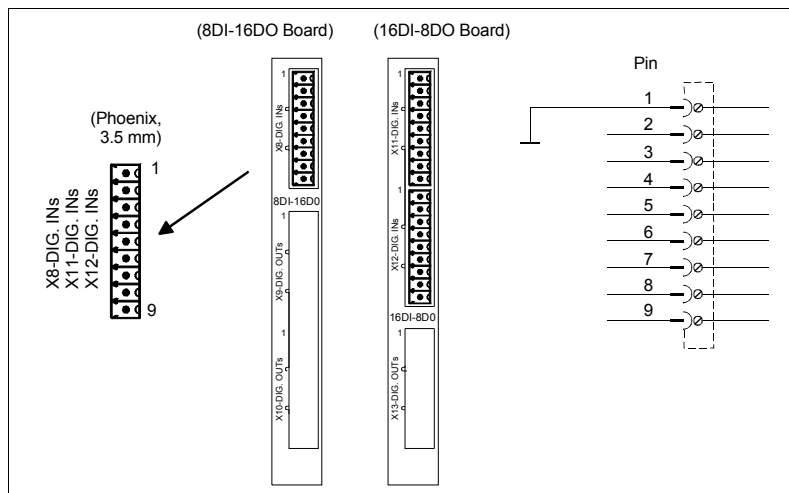

#### F. H3/80

Cards 8DI-16DO and 16DI-8DO. X8-DIG.INs, X11DIG.INs and X12DIG.INs. Digital inputs.

#### Characteristics of the digital inputs (at 24 V)

Rated voltage (maximum)	24 V DC (40 V DC)
ON / OFF voltage	12 V DC / 6 V DC
Typical consumption (max)	5 mA (7 mA)

#### X9-DIG.OUTs, X10-DIG.OUTs, X13-DIG.OUTs, digital outputs

They offer 8 fully programmable digital outputs.

These outputs are optocoupled and of the contact type referred to a common point (pin 1).

Each output is associated with a PLC resource.

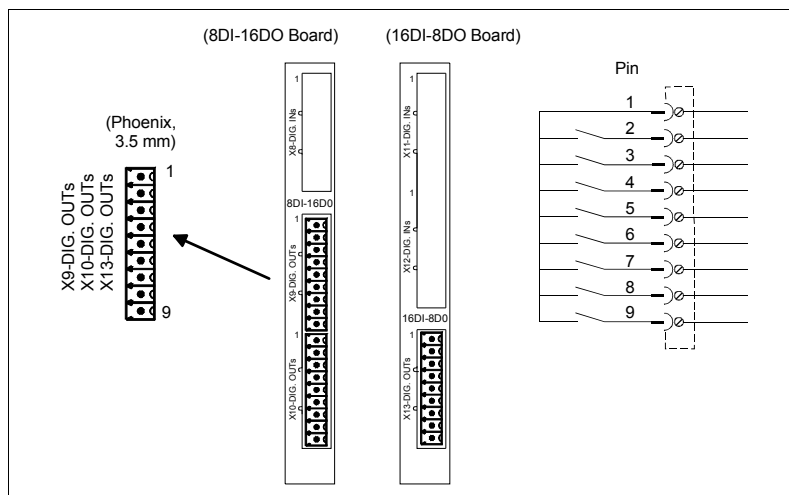

#### F. H3/81

Cards 8DI-16DO and 16DI-8DO. X9-DIG.OUTs, X10-DIG.OUTs and X13-DIG.OUTs. Digital outputs.

**Digital outputs characteristics**

Maximum voltage	250 V
Maximum load current	150 mA
Current autosupply	200 mA
Maximum internal resistance	20 Ω
Galvanic isolation voltage	3750 V (1 min)

**3.**

**DRIVE MODULES**  
Modular drives

**Names of the PLC resources**

Inserting the cards in slots SL1 and SL2 permits all the possible combinations except for two A1 type cards.

At the PLC, the input/output resources can be named according to their location in SL1 and/or SL2:

- The card inserted in slot SL1 numbers the pins from I1 and O1 on.
- The card inserted in slot SL2 numbers the pins from I17 and O17 on.
- The resources are numbered from top to bottom.

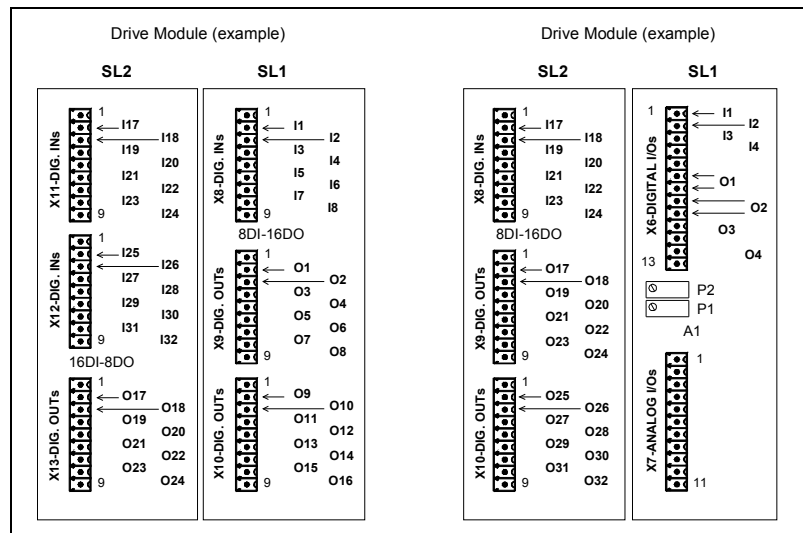

**F. H3/82**

PLC resources on cards located in SL1 and SL2.



DDS  
HARDWARE

Ref.1310

### 3.2 Compact drives

When referring to compact drives, we will use ACD, SCD and CMC. They have the power supply integrated into the module itself and are connected directly to mains. All of them admit a mains voltage between 400 and 460 V AC and, in general, their behavior, functions and parameters are identical to those of the modular drive. See all models in the following figures.

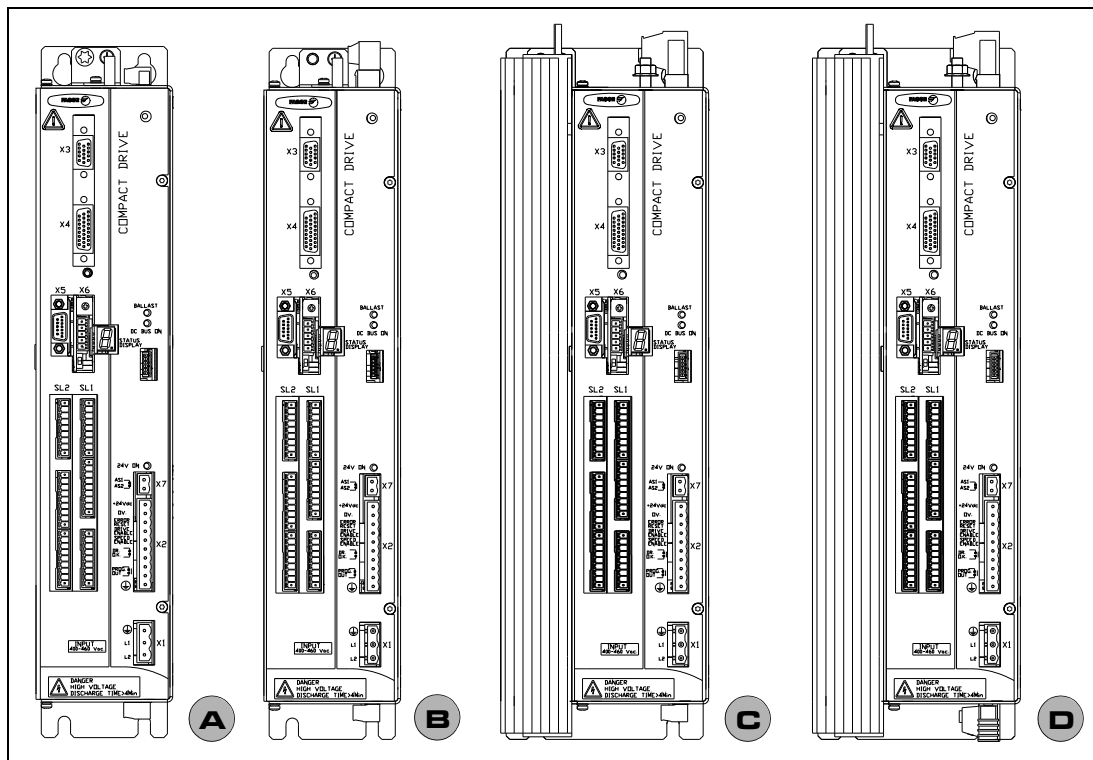

F. H3/83

ACD/SCD compact drives of the FAGOR catalog.

A. ACD/SCD 1.08/1.15, B. ACD/SCD 1.25, C. ACD/SCD 2.35/2.50, D. SCD 2.75.

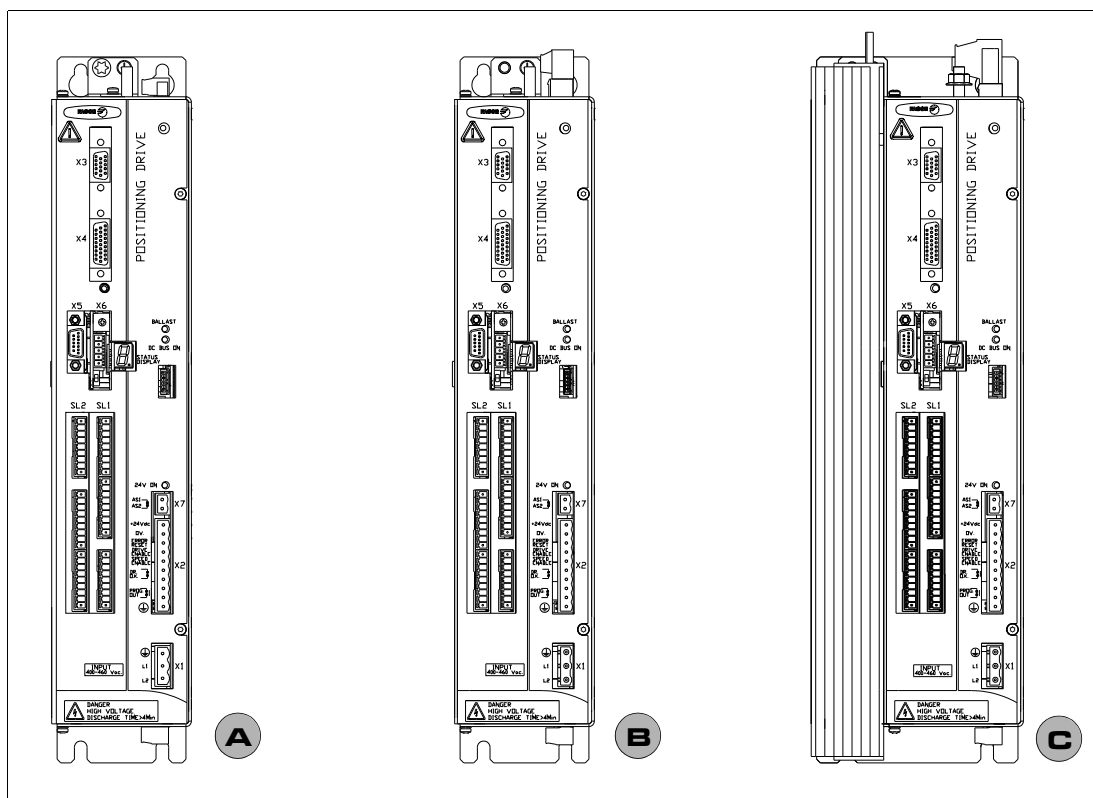

F. H3/84

CMC compact drives of the FAGOR catalog.

A. CMC 1.08/1.15, B. CMC 1.25, C. CMC 2.35/2.50.

**3.**  
DRIVE MODULES  
Compact drives



DDS  
HARDWARE

Ref.1310

**Technical data**

**T. H3/14** Current in compact drives for synchronous motors.  $f_c = 4$  kHz.

With internal fan	Drive for synchronous motor (as axis)				
Currents at $f_c=4$ kHz (A)	<b>ACD/CMC</b> <b>1.08</b>	<b>ACD/CMC</b> <b>1.15</b>	<b>ACD/CMC</b> <b>1.25</b>	<b>ACD/CMC</b> <b>2.35</b>	<b>ACD/CMC</b> <b>2.50</b>
Rated current (Arms)	4.0	7.5	12.5	17.5	25.0
(* ) Maximum peak current for 500 ms in 10 s cycles.	8.0	15.0	25.0	35.0	50.0
Dissipated power (W)	40	87	110	160	222

**T. H3/15** Current in compact drives for synchronous motors.  $f_c = 8$  kHz.

With internal fan	Drive for synchronous motor (as axis)				
Currents at $f_c=8$ kHz (A)	<b>ACD/CMC</b> <b>1.08</b>	<b>ACD/CMC</b> <b>1.15</b>	<b>ACD/CMC</b> <b>1.25</b>	<b>ACD/CMC</b> <b>2.35</b>	<b>ACD/CMC</b> <b>2.50</b>
Rated current (Arms)	4.0	7.5	9.5	17.5	20.0
(* ) Maximum peak current for 500 ms in 10 s cycles.	8.0	15.0	19.0	35.0	40.0
Dissipated power (W)	50	118	139	206	226

**T. H3/16** Current in compact drives for synchronous or asynchronous motors.  $f_c = 4$  kHz.

With internal fan	Drive for synchronous or asynchronous motor (as spindle)				
Currents at $f_c=4$ kHz (A)	<b>SCD</b> <b>1.15</b>	<b>SCD</b> <b>1.25</b>	<b>SCD</b> <b>2.35</b>	<b>SCD</b> <b>2.50</b>	<b>SCD</b> <b>2.75</b>
(* ) Maximum current in any duty cycle (Arms).	10.6	17.5	28.0	38.0	52.0
Dissipated power (W)	123	150	215	275	395

\* This current must be equal to or greater than that of the corresponding asynchronous motor in S6.

**T. H3/17** Current in compact drives for synchronous or asynchronous motors.  $f_c = 8$  kHz.

With internal fan	Drive for synchronous or asynchronous motor (as spindle)				
Currents at $f_c=8$ kHz (A)	<b>SCD</b> <b>1.15</b>	<b>SCD</b> <b>1.25</b>	<b>SCD</b> <b>2.35</b>	<b>SCD</b> <b>2.50</b>	<b>SCD</b> <b>2.75</b>
(* ) Maximum current in any duty cycle (Arms).	10.6	12.5	19.5	27.0	39.0
Dissipated power (W)	123	150	220	315	410

\* This current must be equal to or greater than that of the corresponding asynchronous motor in S6.

**NOTE.** The indicated dissipated power values for the spindles correspond to the operation at rated current in S1 mode.

**3.**  
**DRIVE MODULES**  
Compact drives



DDS  
HARDWARE

Ref.1310

The following table shows other electrical, mechanical and ambient conditions:

**T. H3/18** Technical characteristics of the compact drives.

	ACD/CMC					SCD				
	1.08	1.15	1.25	2.35	2.50	1.15	1.25	2.35	2.50	2.75
Power supply	Three-phase 50/60 Hz, with a voltage range between 400-10% and 460+10% V AC									
Internal power bus voltage	565-650 V DC					565-650 V DC				
Filter capacity (µF) 900 V AC	330	560	680			330	560	680		1150
Energy stored in the capacitors	0.5 C·V <sup>2</sup>									
Internal Ballast resistance (Ω) Power (W)	75 (150)	75 (150)	-	-	-	75 (150)	-	-	-	-
Energy pulse that can be dissipated (kW) Pulse duration (s)	3.5 (0.40)	3.5 (0.40)	-	-	-	3.5 (0.40)	-	-	-	-
Ballast V DC on/off	768 / 760									
Min. Ballast resistance (Ω)	75	75	24	18	18	75	75	24	18	18
Speed feedback	Encoder					Encoder				
Controlling method	PWM, AC sinewave, vector control									
Communication	Serial line to connect to a PC									
Interface	Standard analog or digital via SERCOS (in all models) or CAN bus (in all models) Serial line RS-232/422 (only on CMC models)									
Status display	7-segments display									
Speed range of analog input	1 : 8192									
Current bandwidth	800 Hz									
Speed bandwidth	100 Hz (depends on the motor/drive combination)									
Protections	Over-voltage, over-current, over-speed, heat-sink temperature, ambient temperature, motor temperature, Ballast temperature, hardware error, overload. See chapter 14 of the "man_dds_soft.pdf" manual.									
<b>Power for internal circuits (24 V DC)</b>										
Input voltage	Between 400-10% and 460+10% V AC - 50/60 Hz									
Mains consumption	124.5 mA (400 V AC), 108 mA (460 V AC)									
Output voltage, max. current	24 V DC (5%), 100 A Connector X2, pins 1 and 2.									
<b>Ambient conditions</b>										
Tambient	5 °C/45 °C (41 °F/113 °F) From 40 °C (104 °F) on. See derating curves.									
Storage temperature	- 20 °C/+ 60 °C (- 4 °F/140 °F )									
Sealing	IP 20									
Maximum humidity	< 90% (non condensing at 45 °C/113 °F)									
Operating vibration	0.5 G									
Shipping vibration	2 G									
Approx. mass in kg (lb)	6.0 13.2	6.0 13.2	5.8 12.7	6.1 13.4	6.1 13.4	6.0 13.2	5.8 12.7	6.1 13.4	6.1 13.4	6.1 13.4

3.

**DRIVE MODULES**  
Compact drives

**FAGOR** 

**DDS  
HARDWARE**

Ref.1310

### Load duty cycles

#### Load cycle S1 with current peak

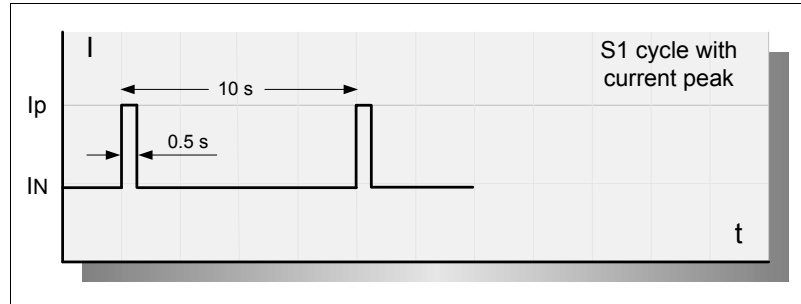

**F. H3/85**

Load cycle S1 with current peak.

#### Load cycle S6

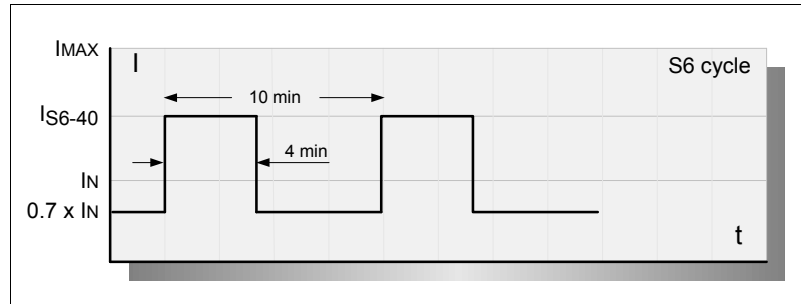

**F. H3/86**

Load cycle S6-40.

#### Load cycle S6 with current peak

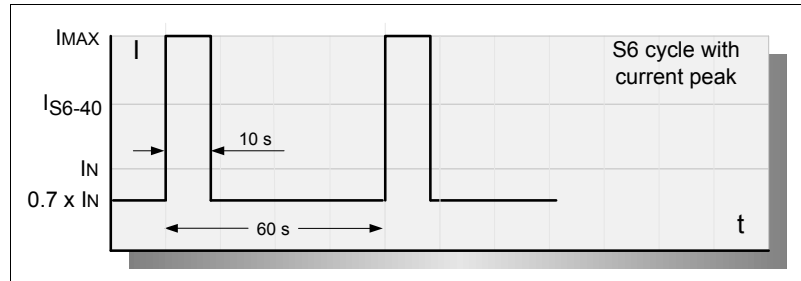

**F. H3/87**

Load cycle S6 with current peak.

#### Definition of currents

On axes:

- $I_n$  → “Continuous duty cycle” current.
- $I_p$  → Peak current.  
See *load duty cycles*.

On spindles:

- $I_n$  → “Continuous duty cycle” current.
- $I_{S6-40\%}$  → Current that, in an intermittent duty cycle S6 with 10 minute cycle, circulates for 4 minutes with load (the other 6 minutes operates without load); in other words with magnetizing current =  $0.7 \times$  rated current  $I_n$ .
- $I_{max}$  → Maximum peak current.  
See *load duty cycles*.

**Note.** The values of these currents are given in RMS.

## Current derating

### Drives for an synchronous motor working as an axis

The following graphs show the maximum rms current in continuous duty cycle (that is, the rated one) depending on the switching frequency of the power transistors that the drive modules for synchronous motors can supply in a temperature range between 5 °C (41 °F) and 60 °C (140 °F).

**NOTE.** They can supply twice as much current for a maximum of 0.5 seconds, and always in cycles longer than 10 seconds.

**3.**

**DRIVE MODULES**  
Compact drives

**FAGOR** 

**DDS  
HARDWARE**

**Ref.1310**

■ For a switching frequency  $f_c = 4$  kHz

**3.**  
**DRIVE MODULES**  
Compact drives

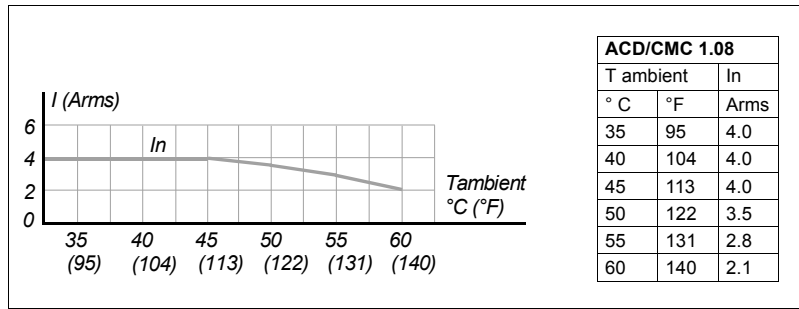

**F. H3/88**

Current derating on “ACD/CMC 1.08” drives for  $f_c = 4$  kHz.

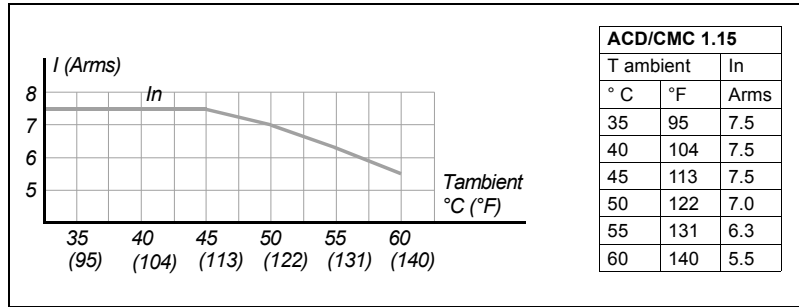

**F. H3/89**

Current derating on “ACD/CMC 1.15” drives for  $f_c = 4$  kHz.

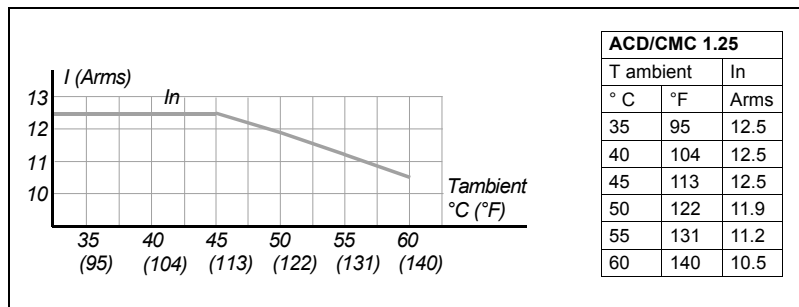

**F. H3/90**

Current derating on “ACD/CMC 1.25” drives for  $f_c = 4$  kHz.

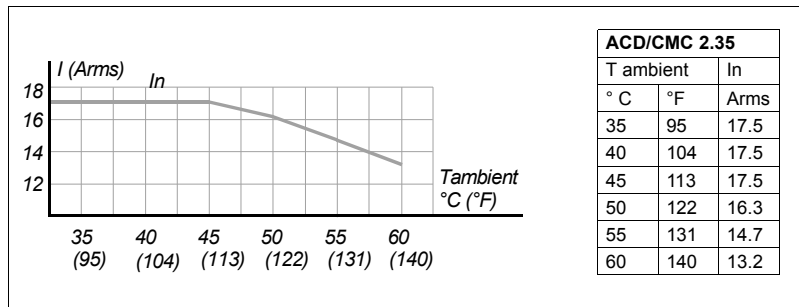

**F. H3/91**

Current derating on “ACD/CMC 2.35” drives for  $f_c = 4$  kHz.

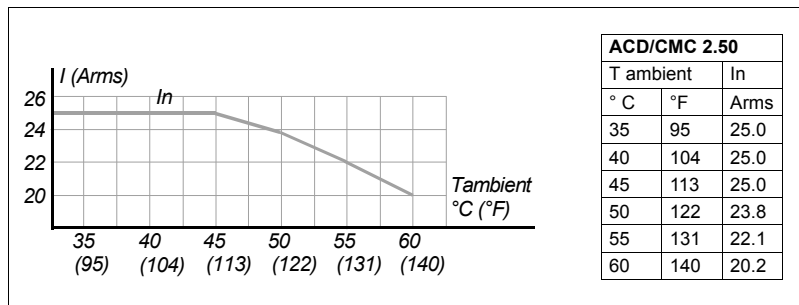

**F. H3/92**

Current derating on “ACD/CMC 2.50” drives for  $f_c = 4$  kHz.



DDS  
HARDWARE

Ref.1310

■ For a switching frequency  $f_c = 8$  kHz

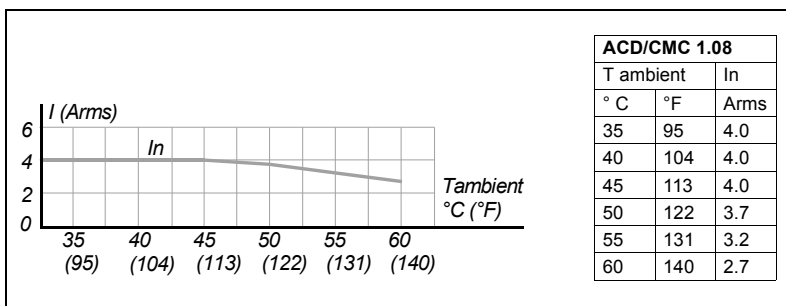

**F. H3/93**

Current derating on "ACD/CMC 1.08" drives for  $f_c = 8$  kHz.

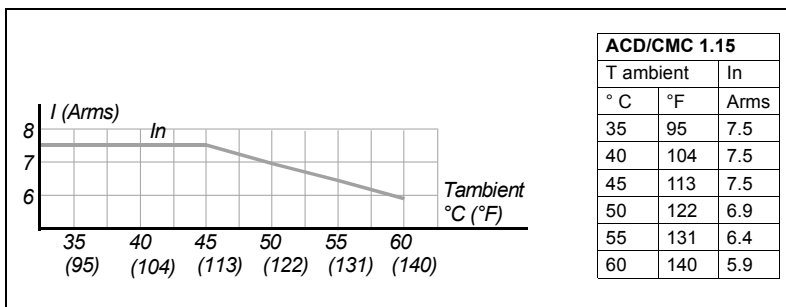

**F. H3/94**

Current derating on "ACD/CMC 1.15" drives for  $f_c = 8$  kHz.

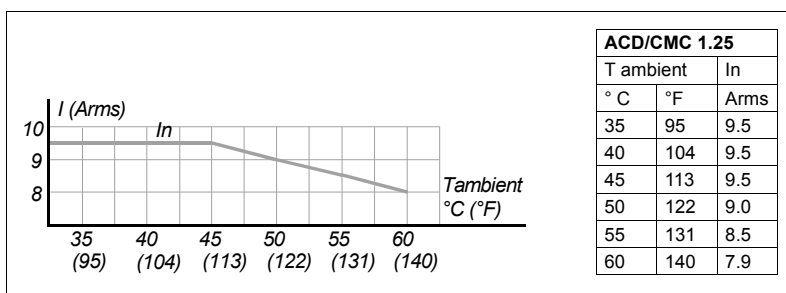

**F. H3/95**

Current derating on "ACD/CMC 1.25" drives for  $f_c = 8$  kHz.

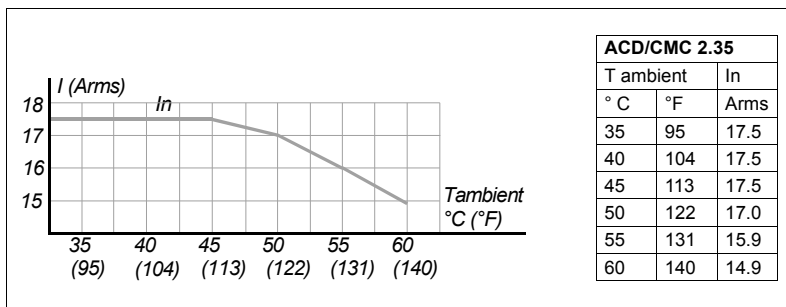

**F. H3/96**

Current derating on "ACD/CMC 2.35" drives for  $f_c = 8$  kHz.

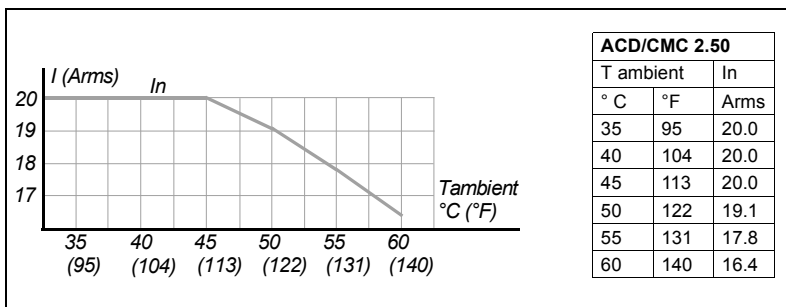

**F. H3/97**

Current derating on "ACD/CMC 2.50" drives for  $f_c = 8$  kHz.

**3.**

**DRIVE MODULES**  
Compact drives



**DDS  
HARDWARE**

**Ref.1310**

**3.**  
**DRIVE MODULES**  
Compact drives

**Drives for a synchronous or asynchronous motor working as a spindle**

The following graphs show the maximum rms current in continuous duty cycle (that is, the rated one) depending on the switching frequency of the power transistors that the drive modules for asynchronous motors can supply in a temperature range between 5 °C (41 °F) and 60 °C (140 °F).

□ For a switching frequency  $f_c = 4$  kHz

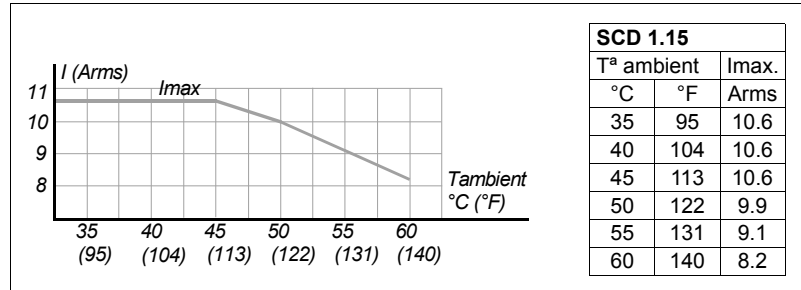

**F. H3/98**

Current derating on “SCD 1.15” drives for  $f_c = 4$  kHz.

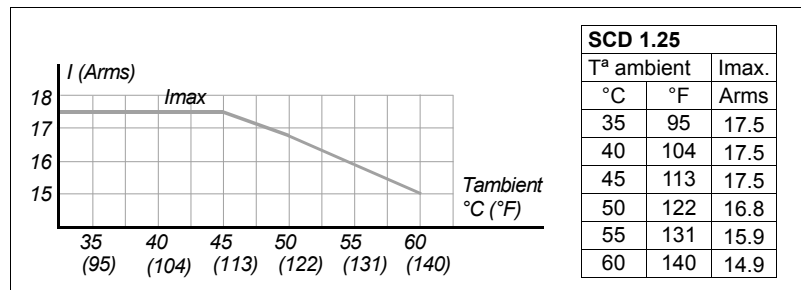

**F. H3/99**

Current derating on “SCD 1.25” drives for  $f_c = 4$  kHz.

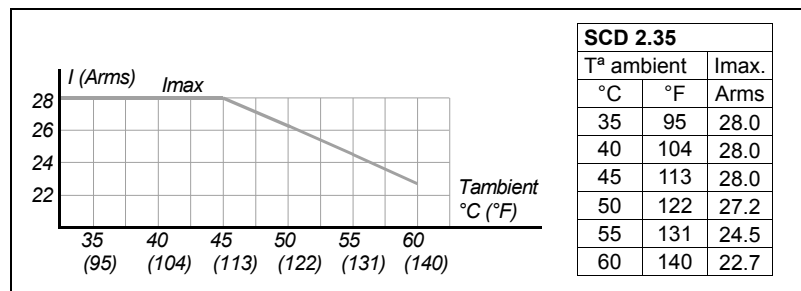

**F. H3/100**

Current derating on “SCD 2.35” drives for  $f_c = 4$  kHz.

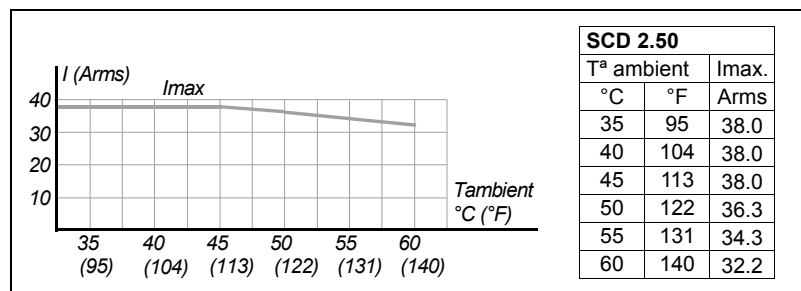

**F. H3/101**

Current derating on “SCD 2.50” drives for  $f_c = 4$  kHz.



DDS  
HARDWARE

Ref.1310

**3.**

**DRIVE MODULES**  
Compact drives

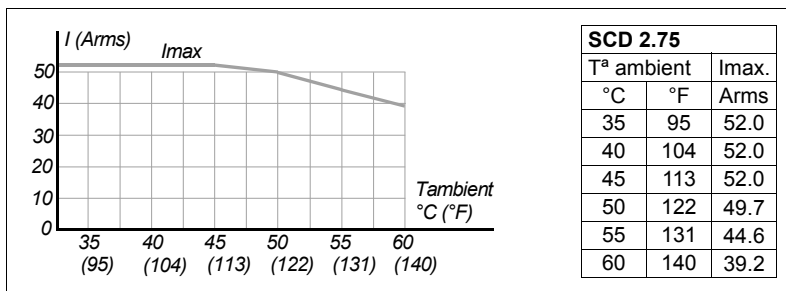

**F. H3/102**

Current derating on “SCD 2.75” drives for  $f_c = 4$  kHz.

□ For a switching frequency  $f_c = 8$  kHz

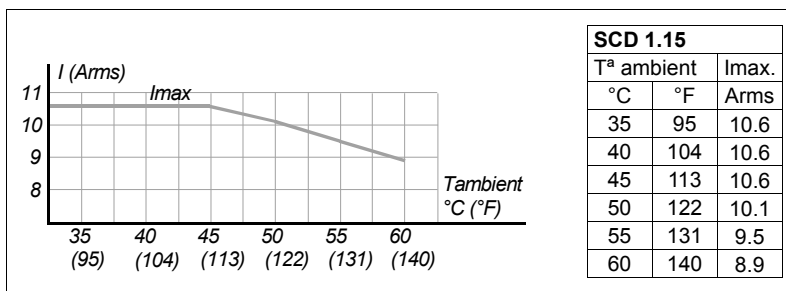

**F. H3/103**

Current derating on “SCD 1.15” drives for  $f_c = 8$  kHz.

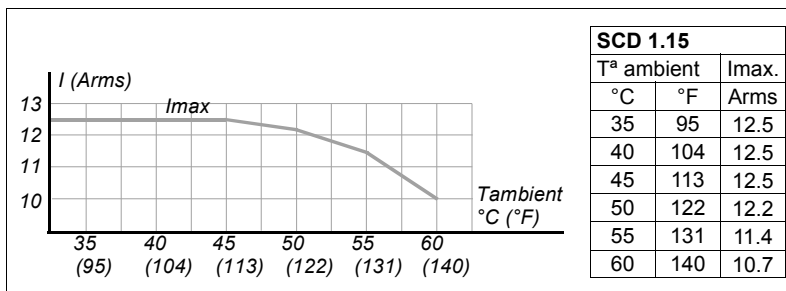

**F. H3/104**

Current derating on “SCD 1.25” drives for  $f_c = 8$  kHz.

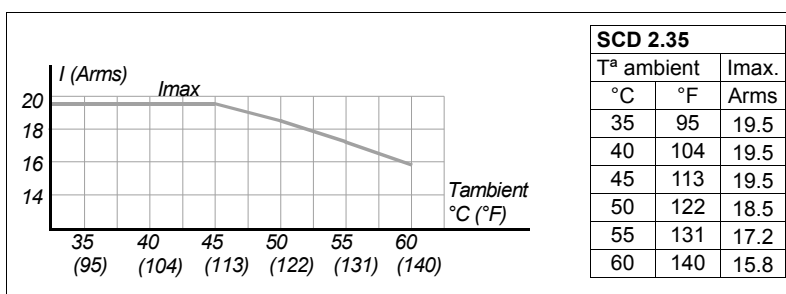

**F. H3/105**

Current derating on “SCD 2.35” drives for  $f_c = 8$  kHz.

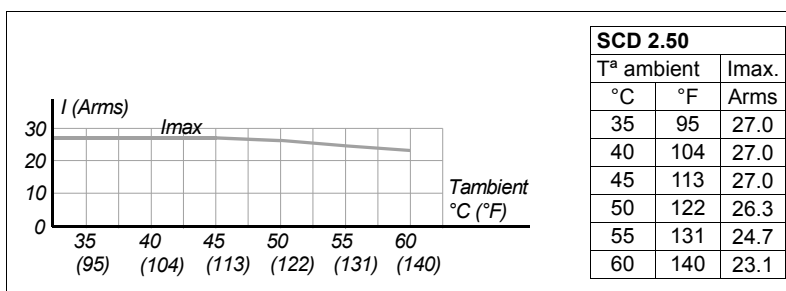

**F. H3/106**

Current derating on “SCD 2.50” drives for  $f_c = 8$  kHz.



**DDS  
HARDWARE**

**Ref.1310**

# 3.

**DRIVE MODULES**  
Compact drives

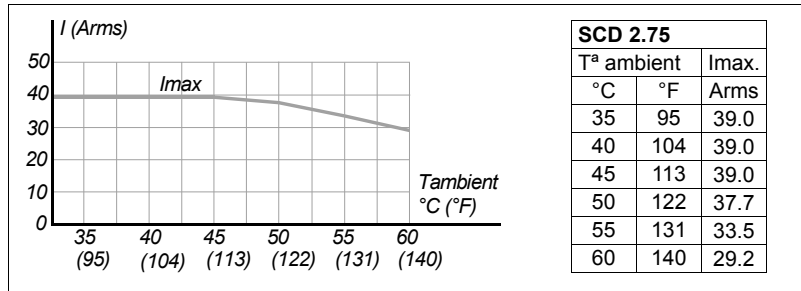

**F. H3/107**

Current derating on “SCD 2.75” drives for  $f_c = 8$  kHz.

**Power derating**

The following graph shows the variation suffered by the output rated power of the compact drive (for all its models) depending on the installation altitude over sea level.

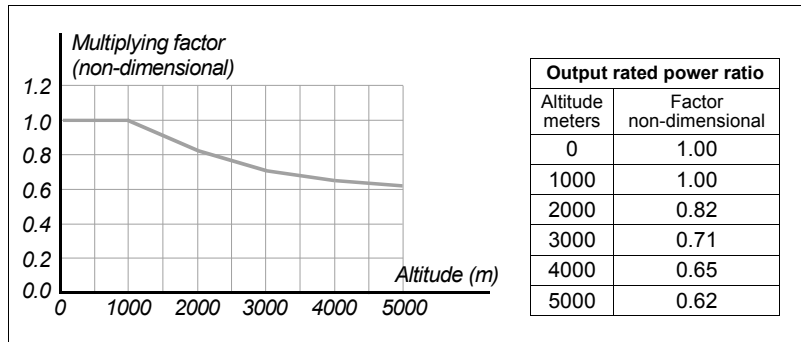

**F. H3/108**

Derating of rated output power depending on the above-sea-level altitude of the installation.



DDS  
HARDWARE

Ref.1310

### Connector layout

The connectors of each compact drive are described next as well as other elements such as indicator lights, status display and so on that are on the front panel of the unit.

Initially it shows each compact drive model and mentions all its connectors and later on, it analyzes all of them one by one in a single section because most of them are the same for all the models.

**3.****DRIVE MODULES**  
Compact drives**FAGOR** **DDS  
HARDWARE****Ref.1310**

**ACD/SCD 1.08/1.15**

These drive modules have the following connectors:

**3.**  
**DRIVE MODULES**  
Compact drives

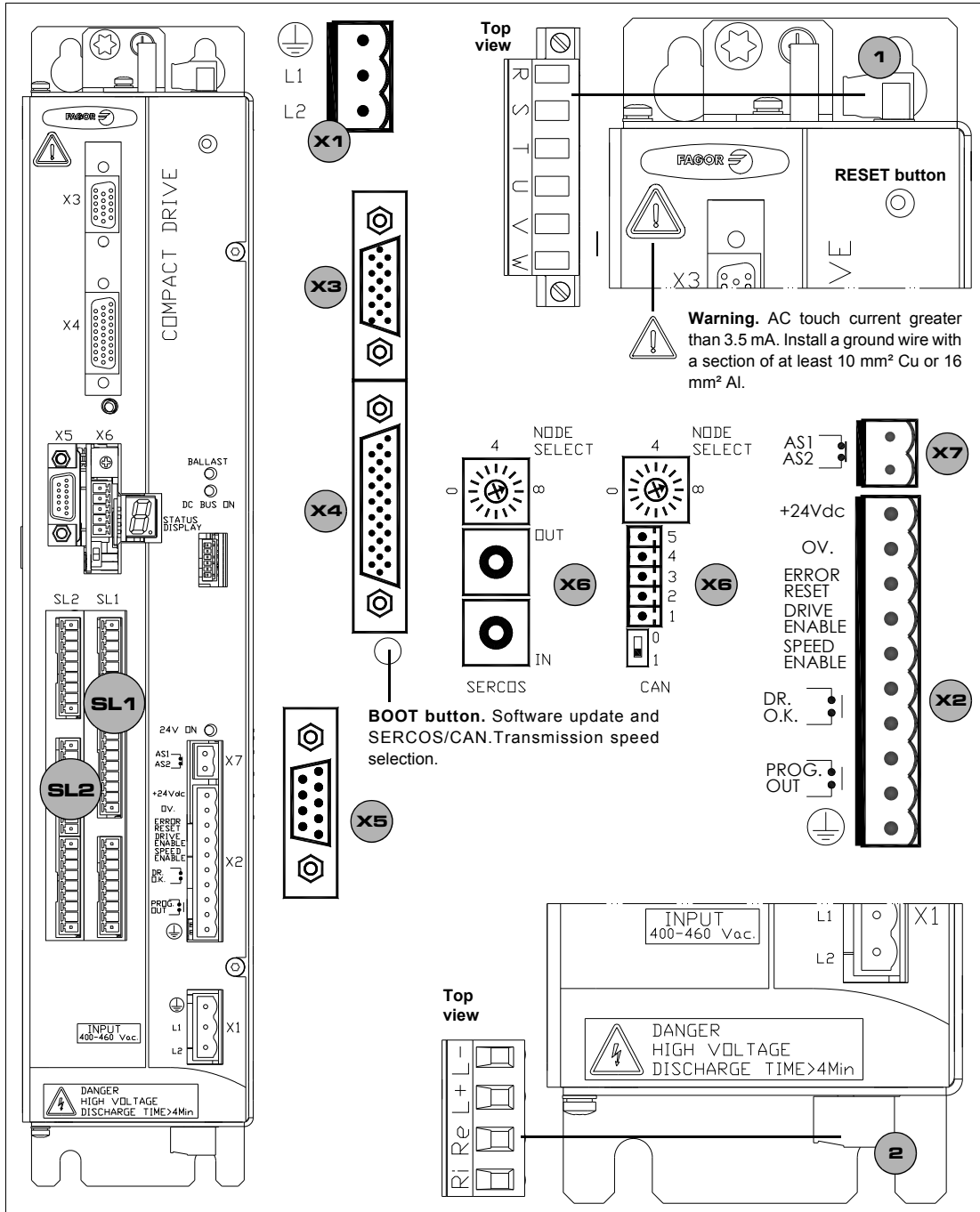

**F. H3/109**

Connectors of "ACD/SCD 1.08/1.15" compact drives.

1. Power connector for motor (U, V, W) and mains connection (R, S, T).
2. Connector for the internal (Ri) or external (Re) Ballast resistor and for accessing the power bus (L+, L-).
- X1. Connector for the internal 24 V DC power supply (two phase 400-460 V AC).
- X2. Connector for the basic control signals.
- X3. Connector with two possible uses:
  - as output of the encoder simulator.
  - as input of the direct feedback for the position loop.
- X4. Connector for motor feedback connection (encoder).
- X5. Connector for RS-232 serial line connection.
- X6. SERCOS or CAN interface connector.
- X7. Connector for external acknowledgment of the status of the safety relay.
- SL1. Slot for the cards A1, 16DI-8DO and 8DI-16DO.
- SL2. Slot for the cards 16DI-8DO and 8DI-16DO.



DDS  
HARDWARE

Ref.1310

### ACD/SCD 1.25

These drive modules have the following connectors:

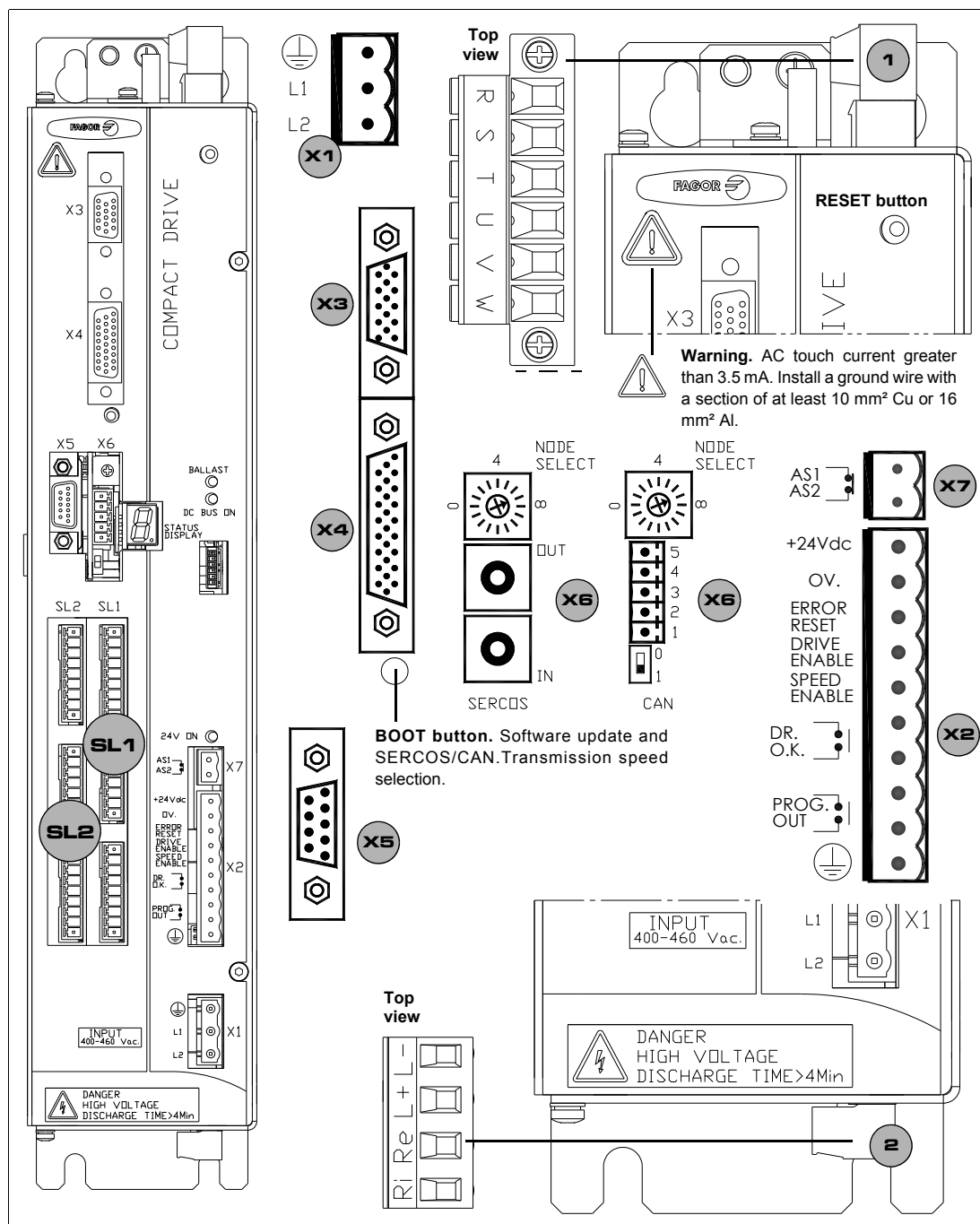

**3.**  
**DRIVE MODULES**  
 Compact drives

#### F. H3/110

Connectors of "ACD/SCD 1.25" compact drives.

1. Power connector for motor (U, V, W) and mains connection (R, S, T).
2. Connector for the external Ballast resistor (Re) and for accessing the power bus (L+, L-). Remember that (Ri) makes no sense in these drives.
- X1. Connector for the internal 24 V DC power supply (two phase 400-460 V AC).
- X2. Connector for the basic control signals.
- X3. Connector with two possible uses:
  - as output of the encoder simulator.
  - as input of the direct feedback for the position loop.
- X4. Connector for motor feedback connection (encoder).
- X5. Connector for RS-232 serial line connection.
- X6. SERCOS or CAN interface connector.
- X7. Connector for external acknowledgment of the status of the safety relay.
- SL1. Slot for the cards A1, 16DI-8DO and 8DI-16DO.
- SL2. Slot for the cards 16DI-8DO and 8DI-16DO.



**DDS  
 HARDWARE**

Ref.1310

**ACD/SCD 2.35/2.50**

These drive modules have the following connectors:

**3.**  
**DRIVE MODULES**  
Compact drives

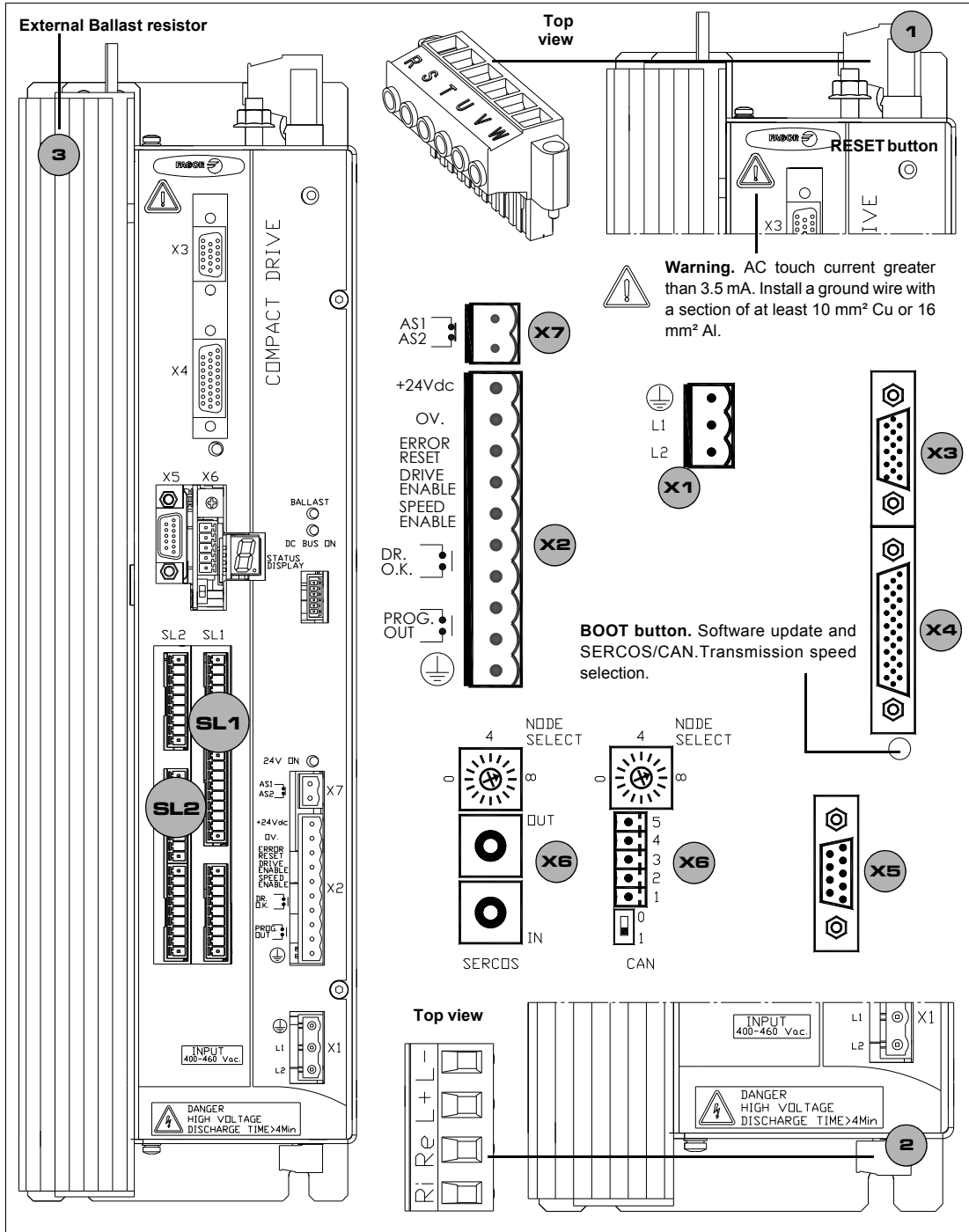

**F. H3/111**

Connectors of "ACD/SCD 2.35/2.50" compact drives.

1. Power connector for motor (U, V, W) and mains connection (R, S, T).
2. Connector for the external Ballast resistor (Re) and for accessing the power bus (L+, L-). Remember that (Ri) makes no sense in these drives.
3. External Ballast resistor.
- X1. Connector for the internal 24 V DC power supply (two phase 400-460 V AC).
- X2. Connector for the basic control signals.
- X3. Connector with two possible uses:
  - as output of the encoder simulator.
  - as input of the direct feedback for the position loop.
- X4. Connector for motor feedback connection (encoder).
- X5. Connector for RS-232 serial line connection.
- X6. SERCOS or CAN interface connector.
- X7. Connector for external acknowledgment of the status of the safety relay.
- SL1. Slot for the cards A1, 16DI-8DO and 8DI-16DO.
- SL2. Slot for the cards 16DI-8DO and 8DI-16DO.



DDS  
HARDWARE

Ref.1310

### SCD 2.75

These drive modules have the following connectors:

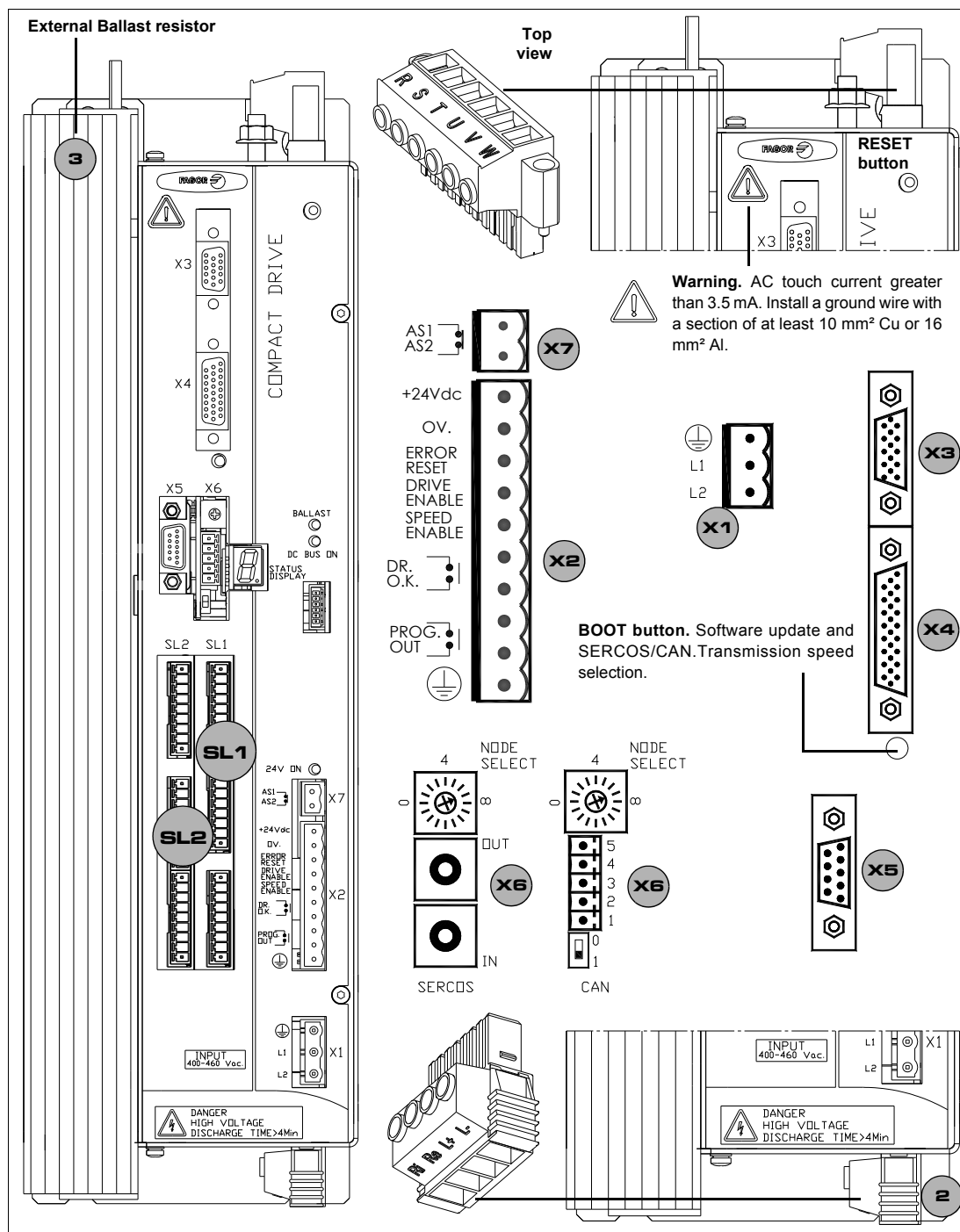

# 3.

**DRIVE MODULES**  
Compact drives

#### F. H3/112

Connectors of "SCD 2.75" compact drives.

1. Power connector for motor (U, V, W) and mains connection (R, S, T).
2. Connector for the external Ballast resistor (Re) and for accessing the power bus (L+, L-). Remember that (Ri) makes no sense in these drives.
3. External Ballast resistor.
- X1. Connector for the internal 24 V DC power supply (two phase 400-460 V AC).
- X2. Connector for the basic control signals.
- X3. Connector with two possible uses:
  - as output of the encoder simulator.
  - as input of the direct feedback for the position loop.
- X4. Connector for motor feedback connection (encoder).
- X5. Connector for RS-232 serial line connection.
- X6. SERCOS or CAN interface connector.
- X7. Connector for external acknowledgment of the status of the safety relay.
- SL1. Slot for the cards A1, 16DI-8DO and 8DI-16DO.
- SL2. Slot for the cards 16DI-8DO and 8DI-16DO.



**DDS  
HARDWARE**

Ref.1310

**CMC 1.08/1.15**

These drive modules have the following connectors:

**3.**  
**DRIVE MODULES**  
Compact drives

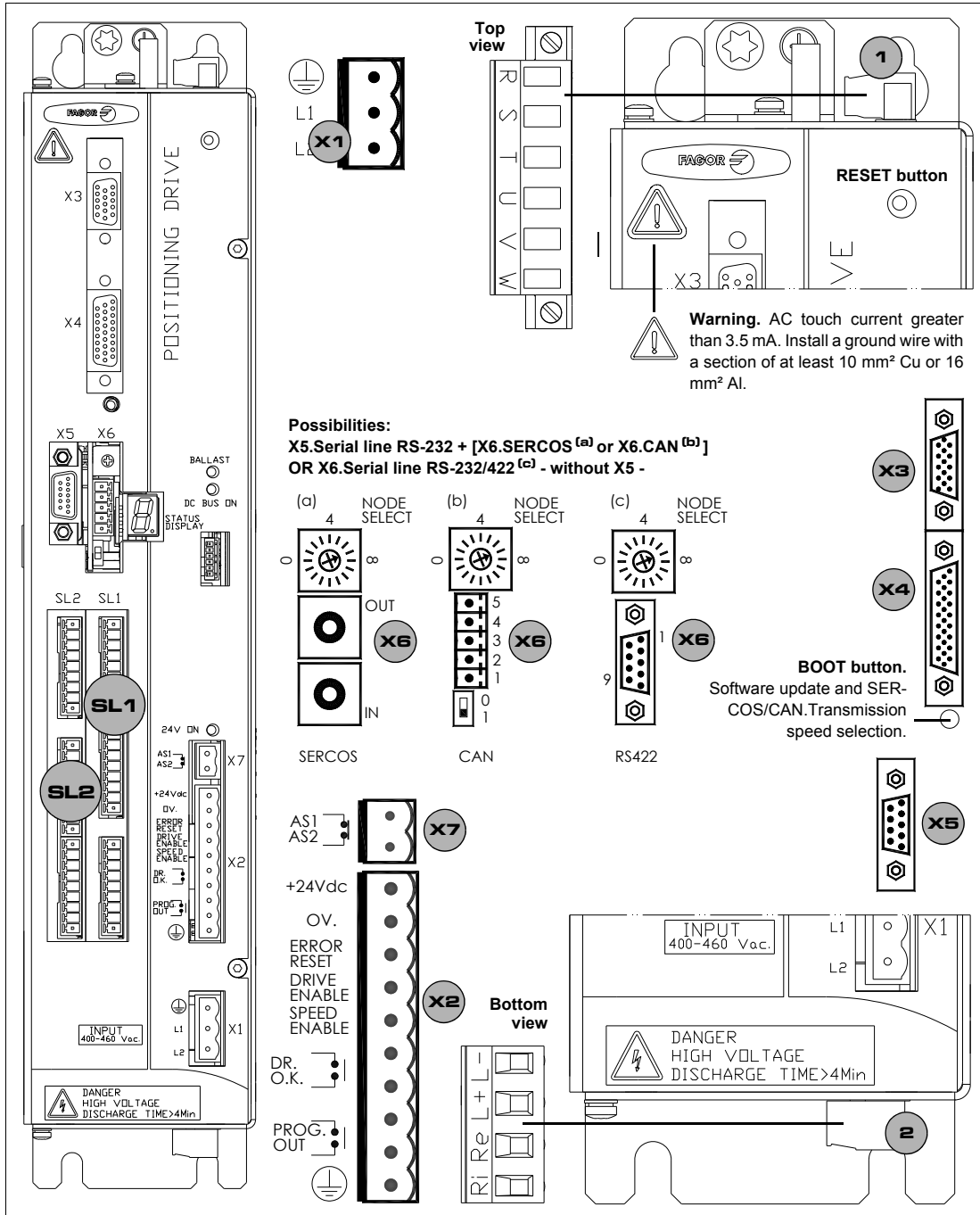

**F. H3/113**

Connectors of "CMC 1.08/1.15" compact drives.

1. Power connector for motor (U, V, W) and mains connection (R, S, T).
2. Connector for the internal (Ri) (only on "1.08/1.15" models) or external (Re) Ballast resistor and for accessing the power bus (L+, L-).
- X1. Connector for the internal 24 V DC power supply (two phase 400-460 V AC).
- X2. Connector for the basic control signals.
- X3. Connector with two possible uses:
  - as output of the encoder simulator.
  - as input of the direct feedback for the position loop.
- X4. Connector for motor feedback connection (encoder).
- X5. Connector for RS-232 serial line connection.
- X6. Possible connectors that may be located in this position:
  - SERCOS <sup>a</sup> or CAN <sup>b</sup> interface connector (always with X5).
  - Connector for RS-232/422 <sup>c</sup> serial line connection (never with X5).
- X7. Connector for external acknowledgment of the status of the integrated safety relay.
- SL1. Slot for the cards A1, 16DI-8DO and 8DI-16DO.
- SL2. Slot for the cards 16DI-8DO and 8DI-16DO.



DDS  
HARDWARE

Ref.1310

**CMC 1.25**

These drive modules have the following connectors:

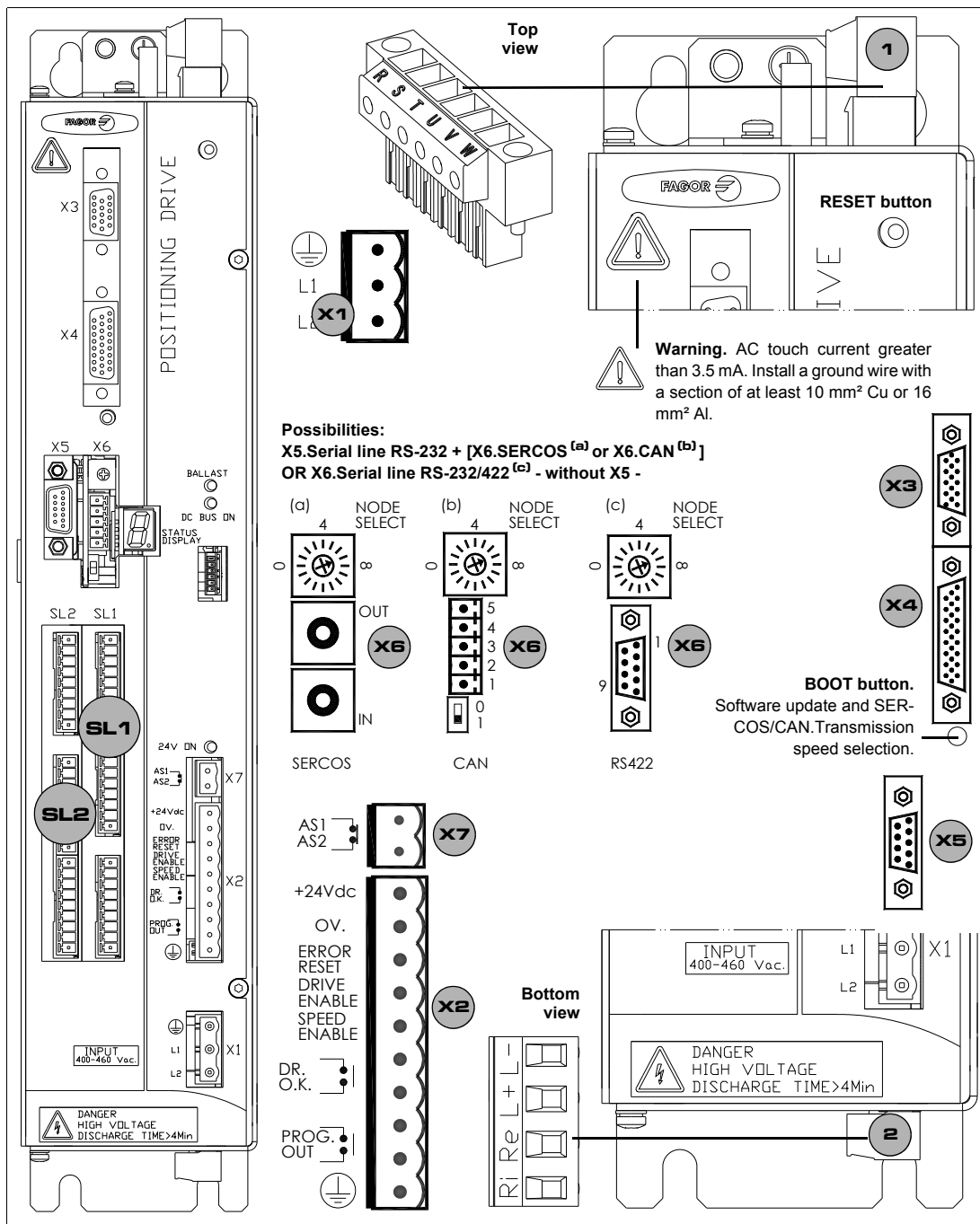

**3.**

**DRIVE MODULES**  
Compact drives

**F. H3/114**

Connectors of "CMC 1.25" compact drives.

1. Power connector for motor (U, V, W) and mains connection (R, S, T).
2. Connector for the external Ballast resistor (Re) and for accessing the power bus (L+, L-). Remember that (Ri) makes no sense in these drives.
- X1. Connector for the internal 24 V DC power supply (two phase 400-460 V AC).
- X2. Connector for the basic control signals.
- X3. Connector with two possible uses:
  - as output of the encoder simulator.
  - as input of the direct feedback for the position loop.
- X4. Connector for motor feedback connection (encoder).
- X5. Connector for RS-232 serial line connection.
- X6. Possible connectors that may be located in this position:
  - SERCOS <sup>a</sup> or CAN <sup>b</sup> interface connector (always with X5).
  - Connector for RS-232/422 <sup>c</sup> serial line connection (never with X5).
- X7. Connector for external acknowledgment of the status of the safety relay.
- SL1. Slot for the cards A1, 16DI-8DO and 8DI-16DO.
- SL2. Slot for the cards 16DI-8DO and 8DI-16DO.



**DDS  
HARDWARE**

**Ref.1310**

**CMC 2.35/2.50**

These drive modules have the following connectors:

**3.**  
**DRIVE MODULES**  
Compact drives

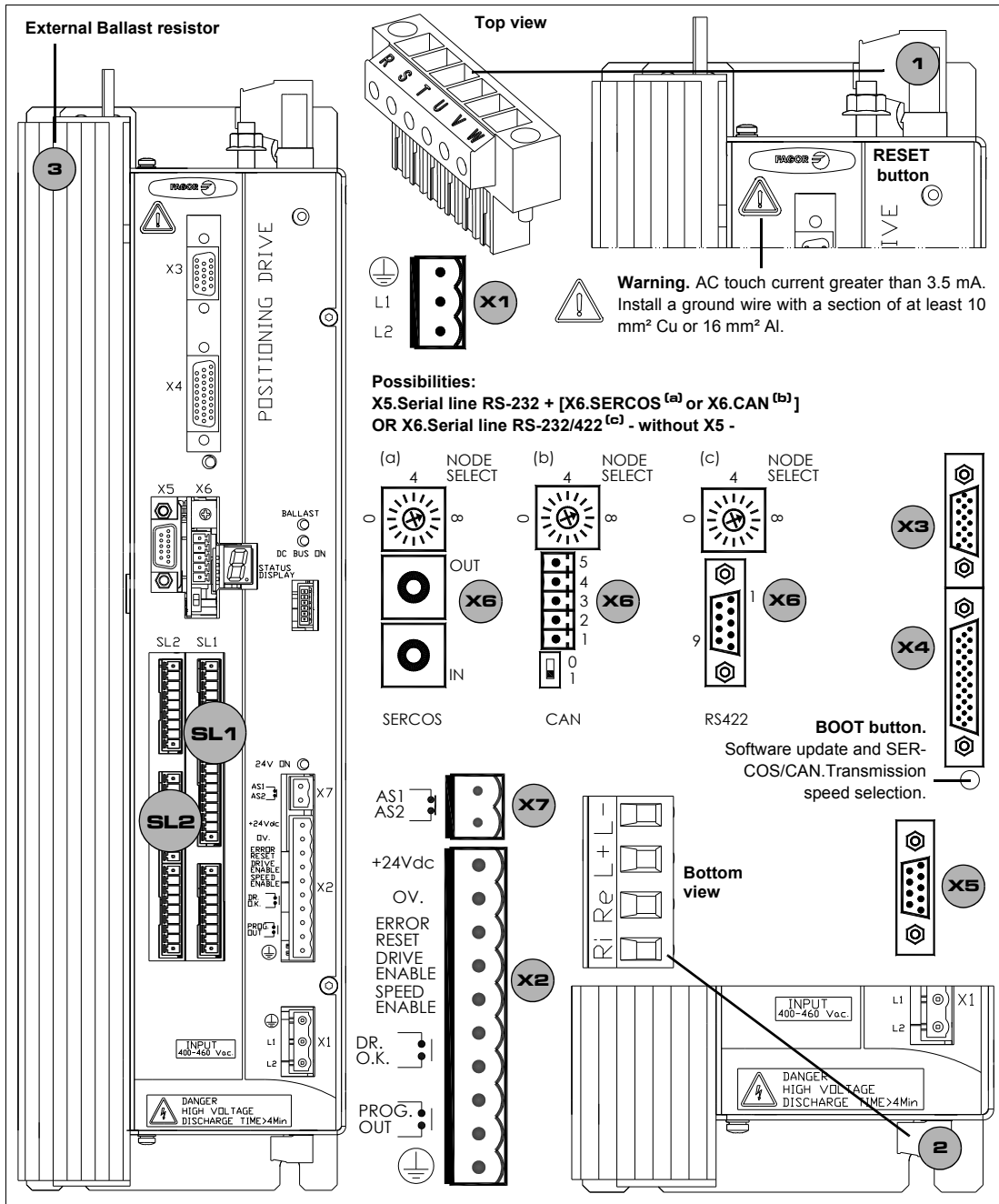

**F. H3/115**

Connectors of "CMC 2.35/2.50" compact drives.

1. Power connector for motor (U, V, W) and mains connection (R, S, T).
2. Connector for the external Ballast resistor (Re) and for accessing the power bus (L+, L-). Remember that (Ri) makes no sense in these drives.
3. External Ballast resistor.
- X1. Connector for the internal 24 V DC power supply (two phase 400-460 V AC).
- X2. Connector for the basic control signals.
- X3. Connector with two possible uses:
  - as output of the encoder simulator.
  - as input of the direct feedback for the position loop.
- X4. Connector for motor feedback connection (encoder).
- X5. Connector for RS-232 serial line connection.
- X6. Possible connectors that may be located in this position:
  - SERCOS<sup>®</sup> or CAN<sup>®</sup> interface connector (always with X5).
  - Connector for RS-232/422<sup>®</sup> serial line connection (never with X5).
- X7. Connector for external acknowledgment of the status of the safety relay.
- SL1. Slot for the cards A1, 16DI-8DO and 8DI-16DO.
- SL2. Slot for the cards 16DI-8DO and 8DI-16DO.



DDS  
HARDWARE

Ref.1310

## Other elements

Besides the various connectors, the front panel of the drive has other elements that are mentioned next.

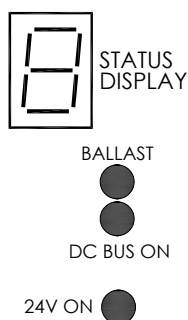

### Status display

The status display shows the information on the drive module status or the corresponding code when an error or warning occurs - see the section "turning a drive on" at the end of this chapter -. It can also display the transmission speed when setting it both with SERCOS or CAN interface.

### Status indicator lamps

The status LED's, when lit, show:

- **BALLAST.** That the Ballast circuit is on
- **DC BUS ON.** That there is power at the bus.
- **24V ON.** There are 24 V DC.

3.

**DRIVE MODULES**  
Compact drives

**FAGOR** 

**DDS  
HARDWARE**

**Ref.1310**

**3.**  
**DRIVE MODULES**  
Compact drives

**Function of the connectors**

**Power connectors**

The power connector on top of each drive module are used to connect the drive to mains (R, S and T) and to the motor (U, V and W).

There is another connector at the bottom of the module to connect the Ballast resistor (Ri, Re) and to access the power bus (L+, L-).

**NOTE.** Note that the ACD/SCD/CMC 1.25/2.35/2.50 and SCD 2.75 models do not have an internal Ballast resistor and, therefore, the power bus will not be charged if a (L+, Ri) configuration is used. **Pin Ri has no function in these modules.** FAGOR provides the external resistor associated with each module as an accessory with the unit and the configuration will always be (L+, Re).



**WARNING.** Note that this connector is only meant for connecting the Ballast resistor. It must never be used to connect a capacitor module because it could destroy the power module.

The ground connection of the cable shields is made from the vertical plate next to the connectors.

The following table shows the values for gap, tightening torque (wire entry holes) and other data regarding the screw-on terminals of the power connectors according to drive model:

**T. H3/19** Technical data of the terminals of the power connector.

	ACD/SCD/CMC			SCD
	1.08 1.15	1.25	2.35 2.50	2.75
<b>Connector data</b>				
Nr of poles	6	6	6	6
Gap (mm)	7.62	7.62	10.16	10.16
Min/max tightening torque (Nm)	0.5/0.6	0.7/0.8	1.7/1.8	1.7/1.8
Screw thread	M3	M3	M4	M4
Min./max. section (mm <sup>2</sup> )	0.2/4	0.2/6	0.75/16	0.75/16
Rated current In (A)	20	41	76	76
<b>Wire data</b>				
Length to strip (mm)	7	10	12	12



**WARNING.** When connecting the drive module with the motor connect terminal U of the drive module with the terminal corresponding to the U phase of the motor. Proceed the same way with the terminals V-V, W-W and PE-PE. Otherwise, it may not work properly.

The cable hose used must have a metallic shield which must be connected to the ground terminal of the drive and to that of the motor (i.e. at both ends) in compliance with the CE seal.



**WARNING.** Observe that before handling these terminals, you must proceed as indicated and in the following order:

- Disconnect the mains voltage at the electrical cabinet.
- Wait a few minutes before handling these terminals.

The power supply needs time to decrease the voltage of the power bus down to safe values (< 42 V DC ). The green indicator DC BUS ON being turned OFF does not mean that the power bus may be handled or manipulated. The discharge time depends on the number of elements connected and it is about 4 minutes.



DDS  
HARDWARE

Ref.1310

The following table shows the values for gap, tightening torque (wire entry holes) and other data regarding the screw-on terminals of the ballast connectors according to drive model:

**T. H3/20** Technical data of aerial connector for the external braking resistor (Ballast) on ACD/SCD/CMC 1.15/1.25/2.35/2.50 drives.

ACD/SCD/CMC	1.08 1.15	1.25	2.35	2.50
<b>Connector data</b>				
Nr of poles	4	4	4	4
Gap (mm)	7.62	7.62	7.62	7.62
Min/max tightening torque (Nm)	0.5/0.6	0.5/0.6	0.5/0.6	0.5/0.6
Screw thread	M3	M3	M3	M3
Min./max. section (mm <sup>2</sup> )	0.2/2.5	0.2/2.5	0.2/2.5	0.2/2.5
Rated current I <sub>n</sub> (A)	12	12	12	12
<b>Wire data</b>				
Length to strip (mm)	7	7	7	7

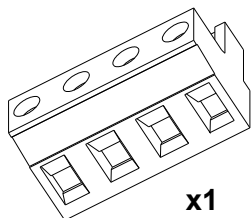

**T. H3/21** Technical data of aerial connector for the external braking resistor (Ballast) on SCD 2.75.

SCD	2.75			
<b>Connector data</b>				
Nr of poles	4			
Gap (mm)	7.62			
Min/max tightening torque (Nm)	0.7/0.8			
Screw thread	M3			
Min./max. section (mm <sup>2</sup> )	0.2/6			
Rated current I <sub>n</sub> (A)	41			
<b>Wire data</b>				
Length to strip (mm)	10			

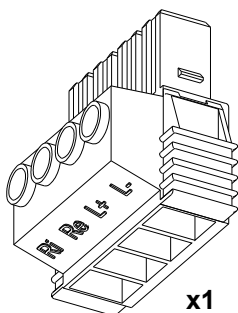

**WARNING.** On ACD/SCD/CMC 1.08/1.15 modules, if an external Ballast resistor (for braking) is going to be connected, make sure that its Ohm value is exactly the same as that of the internal Ballast resistor. See table **T. H3/18** which indicates this value. The rest of the compact modules have no internal Ballast resistor; therefore, always install the external Ballast resistor supplied by FAGOR with the unit.

The terminals (R<sub>i</sub>, R<sub>e</sub> and L<sub>+</sub>) are used to configure the Ballast circuit whose purpose is to dissipate the energy generated while braking the motor.

By jumpering the terminals (R<sub>i</sub> and L<sub>+</sub>), the system is configured so as to work with the internal resistor of the compact drive module; this configuration, as mentioned earlier, can only be set for ACD/SCD/CMC 1.08/1.15 models.

**NOTE.** Never configure models **ACD/SCD/CMC 1.25/2.35/2.50** and **SCD 2.75** with internal Ballast resistor (jumper between R<sub>i</sub> and L<sub>+</sub>). These modules do not have an internal Ballast resistor. If this warning is ignored and a (L<sub>+</sub>, R<sub>i</sub>) configuration is used instead of (L<sub>+</sub>, R<sub>e</sub>), either unknowingly or inadvertently, there is no risk of destroying the module, but the power bus will not charge. Remember that pin R<sub>i</sub> has no function in these modules.

Up to 45 °C (113 °F), this resistor dissipates the power indicated in the technical data table. See table **T. H3/18**.

All the modules carry a protection against over-temperature which issues an error E301 when reaching 105 °C (221 °F).

**3.**

**DRIVE MODULES**  
Compact drives



**DDS  
HARDWARE**

**Ref.1310**

In ACD/SCD/CMC 1.08/1.15 models, the jumper between (Ri and L+) may be removed and an external resistor may be connected between (Re and L+) for dissipating energy.

**3.**

**DRIVE MODULES**  
Compact drives

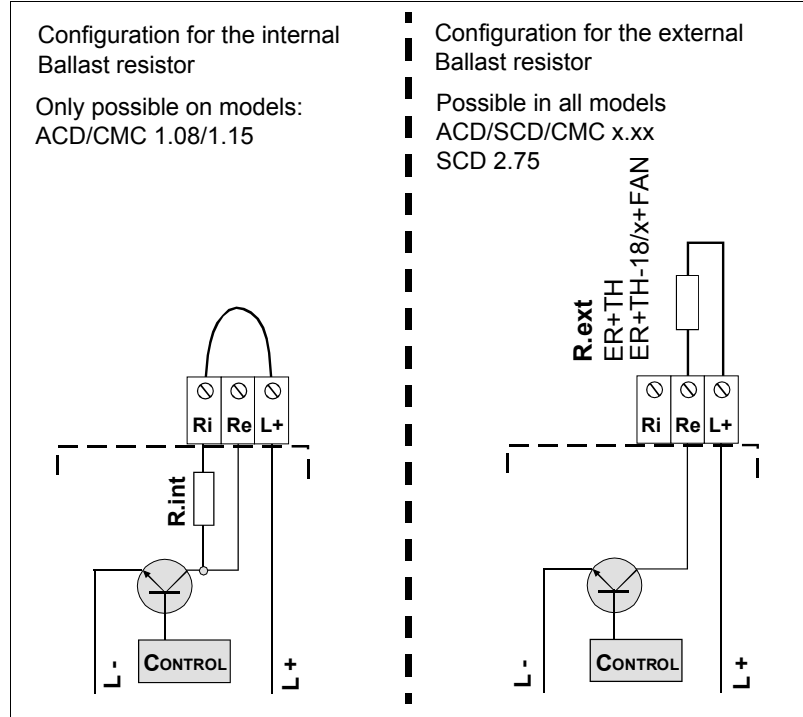

F. H3/116

Ballast resistor configurations.



DDS  
HARDWARE

Ref.1310

**X1 connector**

Compact drives internally generate the 24 V DC necessary for the internal circuits.

In regular operation, this voltage is obtained from the power bus and from mains when starting up the system.

It is a three-pin connector used to supply from mains the necessary start-up energy.

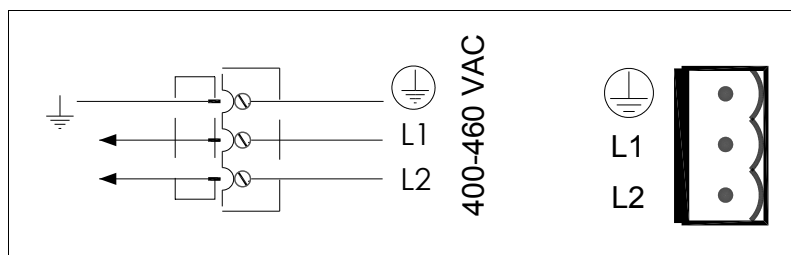

**F. H3/117**

Connector X1. 24 V DC.

The start-up process needs an internal module test prior to supplying power to the upper terminals. Therefore, bear in mind the following warning:



**WARNING.** This internal power supply must be powered through connector X1 before carrying out any electrical maneuver.

Current from mains phases to these lines L1 and L2 must be obtained from a point before the contactor providing the three - phase power to the upper connectors of the compact drive.

The following table shows the values for gap, tightening torque (wire entry holes) and other data regarding the screw-on terminals of the plug-in connector for X1 according to drive model:

**T. H3/22** Technical data of the aerial plug-in connector for X1.

	<b>ACD/SCD/CMC</b>	<b>SCD</b>
	<b>1.08/1.15/1.25/2.35/2.50</b>	<b>2.75</b>
<b>Connector data</b>		
Nr of poles	3	3
Gap (mm)	7.62	7.62
Min/max tightening torque (Nm)	0.5/0.6	0.5/0.6
Screw thread	M3	M3
Min./max. section (mm <sup>2</sup> )	0.2/2.5	0.2/2.5
Rated current I <sub>n</sub> (A)	12	12
<b>Wire data</b>		
Length to strip (mm)	7	7

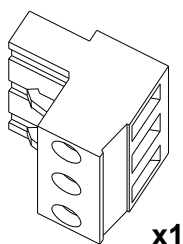

**3.**  
DRIVE MODULES  
Compact drives



DDS  
HARDWARE

Ref.1310

**3.**  
**DRIVE MODULES**  
Compact drives

**X2 connector**

10-pin connector of the compact drive and integrates the functions of the power supply and the modular drive.

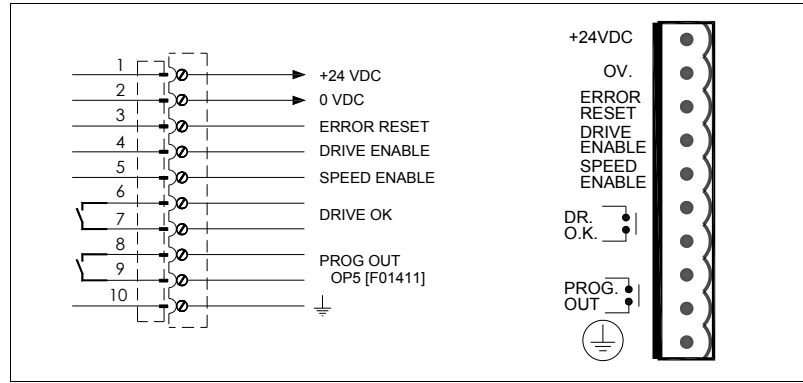

**F. H3/118**

Connector X2. Control.

The following table shows the values for gap, tightening torque (wire entry holes) and other data regarding the screw-on terminals of the aerial plug-in connector for X2 according to drive model:

**T. H3/23** Technical data of the aerial plug-in connector for X2.

	<b>ACD/SCD/CMC</b>	<b>SCD</b>
	<b>1.08/1.15/1.25/2.35/2.50</b>	<b>2.75</b>
<b>Connector data</b>		
Nr of poles	10	10
Gap (mm)	5.00	5.00
Min/max tightening torque (Nm)	0.5/0.6	0.5/0.6
Screw thread	M3	M3
Min./max. section (mm <sup>2</sup> )	0.2/2.5	0.2/2.5
Rated current I <sub>n</sub> (A)	12	12
<b>Wire data</b>		
Length to strip (mm)	7	7

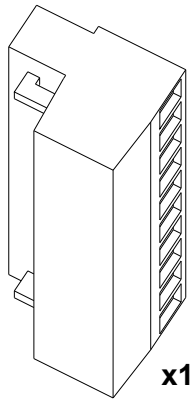

**Specific of the power supply**

With the Error Reset input (pin 3), it is possible to remove the errors at a compact drive. See “resettable errors” of chapter 14 of the “man\_dds\_soft.pdf” manual. Hence, activating this input (24 V DC) eliminates the resettable errors.

If the cause of the error persists, the status display will show the same error again.

But if it is a major error, it can only be eliminated by powering the unit off and back on.

Pins 1 and 2 offer a 24 V DC output for the user.

The maximum output current is 100 mA.

**Specific functions of the modular drive**

Control signals. With the “Drive Enable” and “Speed Enable” inputs (pins 4 and 5) together with the velocity command, it is possible to govern the motor.

The consumption of these control signals is between 4.7 and 7 mA.

The following page describes the behavior of the drive depending on these control signals.

The “Drive Ok” contact (pins 6 and 7) will stay closed as long as the compact drive runs properly.



**DDS  
HARDWARE**

**Ref.1310**

**Other functions**

The “Prog. Out” contact (pins 8 and 9) is a user programmable output by means of an internal parameter of the drive. See parameter OP5 in chapter 13 of the “man\_dds\_soft.pdf” manual.

The description of the pins of this connector is:

**T. H3/24** Description of the pins of connector X2 of the compact drive.

1	+24 V DC (OUT)	Power supply selection	Positive voltage output (24 V DC, 100 mA).
2	0 V. (OUT)		Reference 0 V.
3	ERROR RESET	System error reset input (24 V DC), (4.5-7 mA).	
4	DRIVE ENABLE	Control signals	Motor current enable (24 V DC).
5	SPEED ENABLE		Drive speed enable (24 V DC).
6	DR. OK.	Module status contact (open when failure)	
7	DR. OK.		
8	PROG. OUT	Programmable internal contact Limit: 1 A at 24 V DC.	
9	PROG. OUT		
10	CHASSIS	Chassis connection	

**3.**

**DRIVE MODULES**  
Compact drives

**SPEED ENABLE AND DRIVE ENABLE**

**Normal operating mode**

1. Activate the Drive Enable and Speed Enable inputs (24 V DC) in the desired order. Before activating, the Soft Start process (smoothly reaching the power bus voltage) must be over. The motor will have torque only when Drive Enable is active and there is voltage at the power bus. The motor speed will be controlled with a command when the Speed Enable function is active.



**INFORMATION.** Activating the Drive Enable function requires to be requested by the system in three different ways. They are: Electrical signal at connector X2, variable BV7 (F00203), and variable DRENA of the PLC when using the SERCOS or CAN interface. It could be deactivated through any of them.

2. The motor will respond to all analog command variations only while both inputs (Drive Enable and Speed Enable) are at 24 V DC. If any of them is deactivated, the following will happen. See the operation modes in figure F. H3/119.

**Deactivation of the Drive Enable input**

The Drive Enable input lets the current circulate through the motor stator windings. When it is powered with 24 V DC the current is enabled and the drive can work.

If the Drive Enable input drops to 0 V DC (no voltage), the power circuit is off and the motor will have not torque, hence not being governed and will turn freely until it stops by friction.

**Deactivation of the Speed Enable input**

When the Speed Enable input is set to 0 V DC, the internal velocity command follows the stop ramp set by parameter and:

**□ Situation 1**

The torque is kept active by braking the motor. When it stops, variable SV5 (S00331) is activated. The motor has stopped in a time period shorter than the one indicated by parameter GP3 (F00702). The torque is canceled and the rotor is free.



**DDS  
HARDWARE**

**Ref.1310**

□ Situation 2

**3.**  
**DRIVE MODULES**  
Compact drives

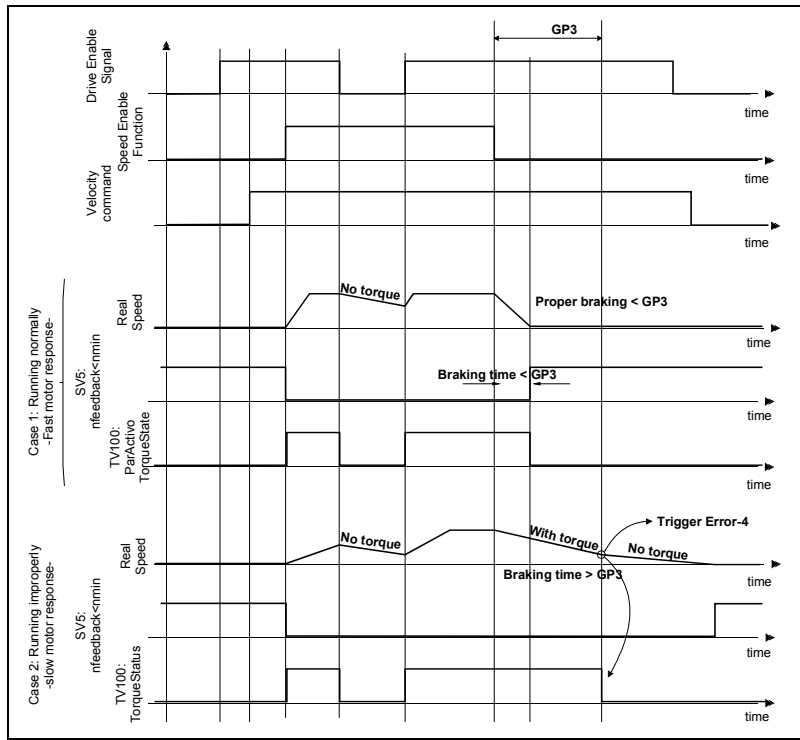

**F. H3/119**

Operating modes of functions Drive Enable and Speed Enable.

The torque is kept active by braking the motor. When it stops, variable SV5 (S00331) is activated. The motor does not stop in a time period set by parameter GP3 (F00702). The motor stops when its kinetic energy runs out.

See the internal parameter GP3 (F00702) and the internal variable SV5 (S00331) in chapter 13 of the “man\_dds\_soft.pdf” manual that is supplied with this one.



**WARNING.** In case of mains failure, the control circuit and its signals must maintain their 24 V DC while the motors are braking.

In the case of the compact drive, the 24 V DC at pins 1 and 2 of connector X2 meet this requirement and are appropriate for managing the control signals.



DDS  
HARDWARE

Ref.1310

### X3 connector

This connector of the compact drive offers two possible configurations:

- Encoder simulator
- Direct feedback

#### X3. Encoder simulator

Having installed the encoder simulator card, X3 is a high density (HD) 15-pin sub-D type male (M) connector whose pins are galvanically isolated from the rest of the drive.

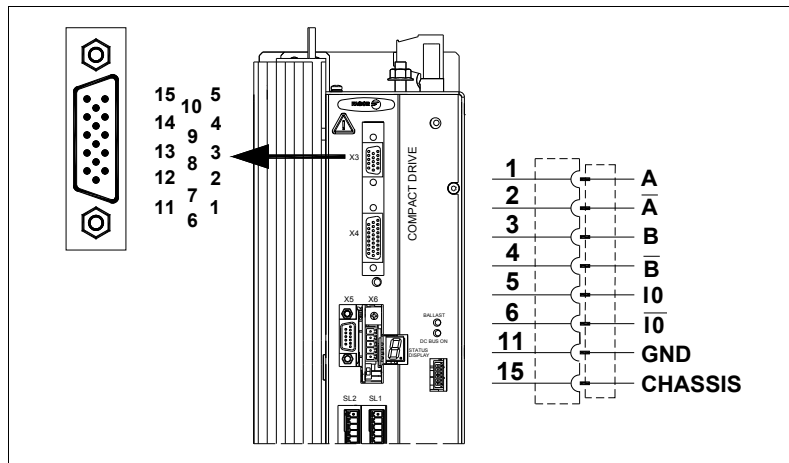

#### F. H3/120

Connector X3. Pinout.

It outputs square differential TTL pulses simulating those of an encoder that would be mounted on the motor shaft.

The number of pulses per turn and the position of the reference mark I0 are programmable.

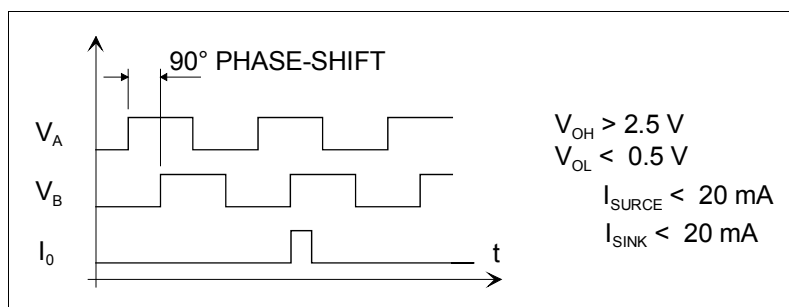

#### F. H3/121

Connector X3. Pulses per revolution and reference mark position.

**3.**  
**DRIVE MODULES**  
 Compact drives

**X3. Direct feedback**

Having installed a direct feedback card, X3 is a high density (HD) 15-pin sub-D type female (F) connector.

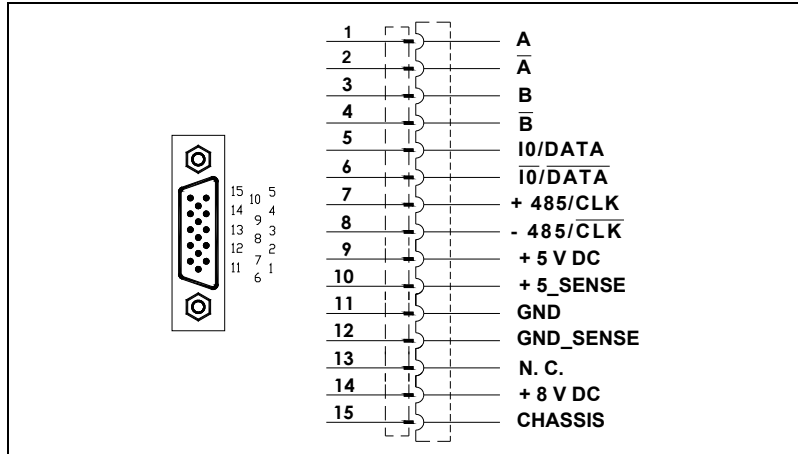

**F. H3/122**

Connector X3. Pinout.

It supports the following signals:

- Square single-ended TTL
- Square differential (double-ended) TTL
- 1 Volt peak-to-peak sinusoidal (1 Vpp)
- SSI
- EnDat

and the following frequencies:

- 1 MHz with square signals
- 500 kHz with sinusoidal signals

The input impedance for sinusoidal signals is 120 Ω.



DDS  
 HARDWARE

Ref.1310

With external incremental feedback device

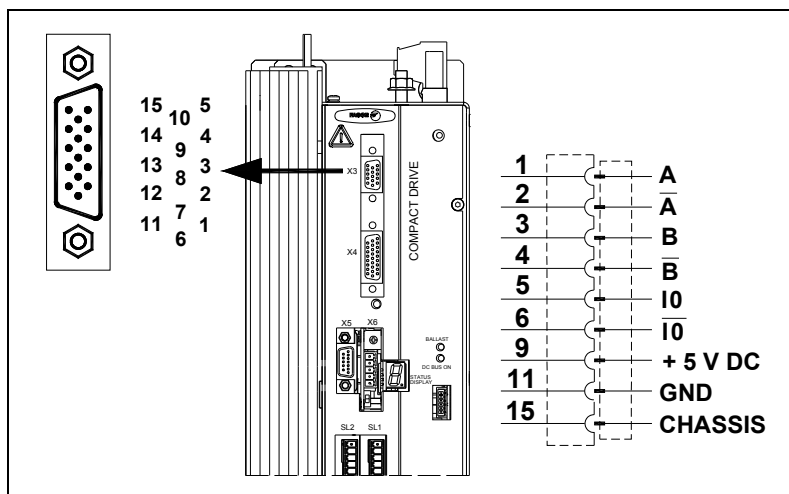

F. H3/123

Connector X3. Signals sent by an external incremental feedback device.

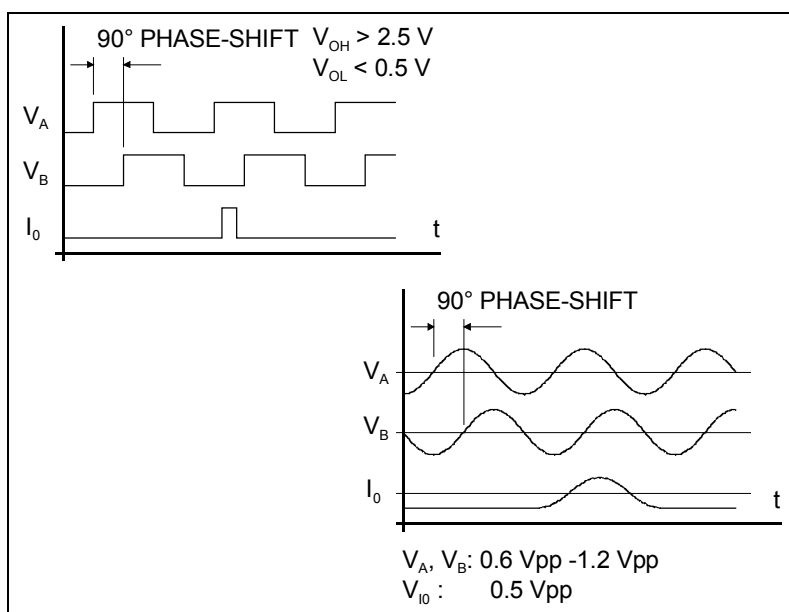

F. H3/124

Characteristics of the square TTL signals and 1Vpp sinusoidal signals.

**3.**  
**DRIVE MODULES**  
 Compact drives



DDS  
 HARDWARE

Ref.1310

**3.**

**DRIVE MODULES**  
Compact drives

**With external absolute feedback device**

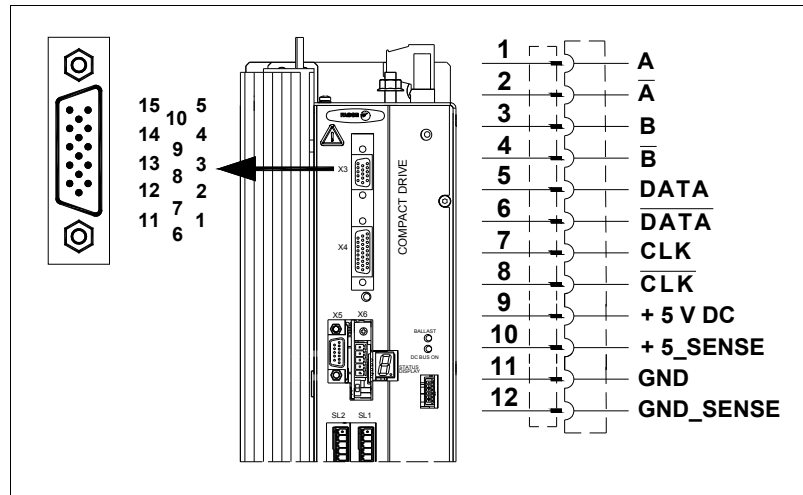

**F. H3/125**

Connector X3. Signals sent by an external absolute feedback device.

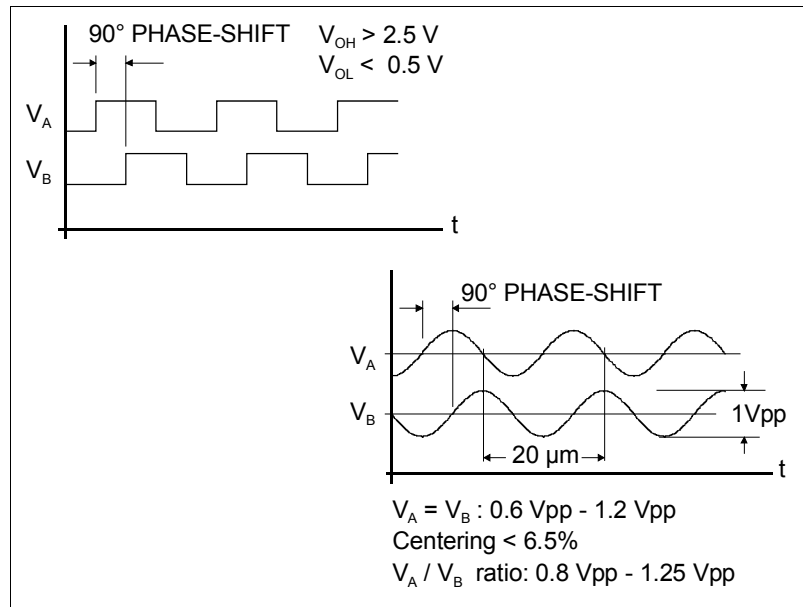

**F. H3/126**

Characteristics of the square TTL signals and 1 Vpp sinusoidal signals.

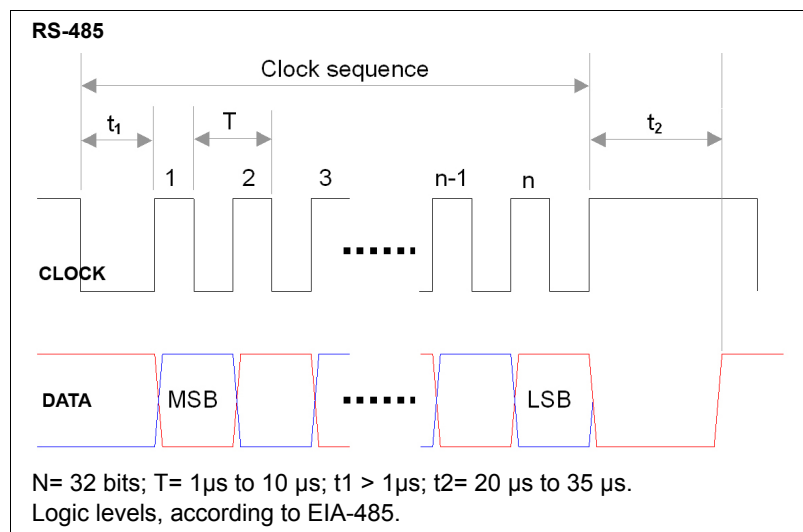

**F. H3/127**

Characteristics of absolute signals in an SSI communication.



DDS  
HARDWARE

Ref.1310

### X4 connector

#### X4. Motor feedback

Connector for the motor feedback board that may come on compact drives. It is a high density (HD) 26-pin sub-D type female connector. Through it, the board receives the signals coming from the feedback device attached to the motor shaft.

The pinout of connector X4 depending on whether the motor feedback board installed at the drive is a CAPMOTOR-1 or a CAPMOTOR-2 is:

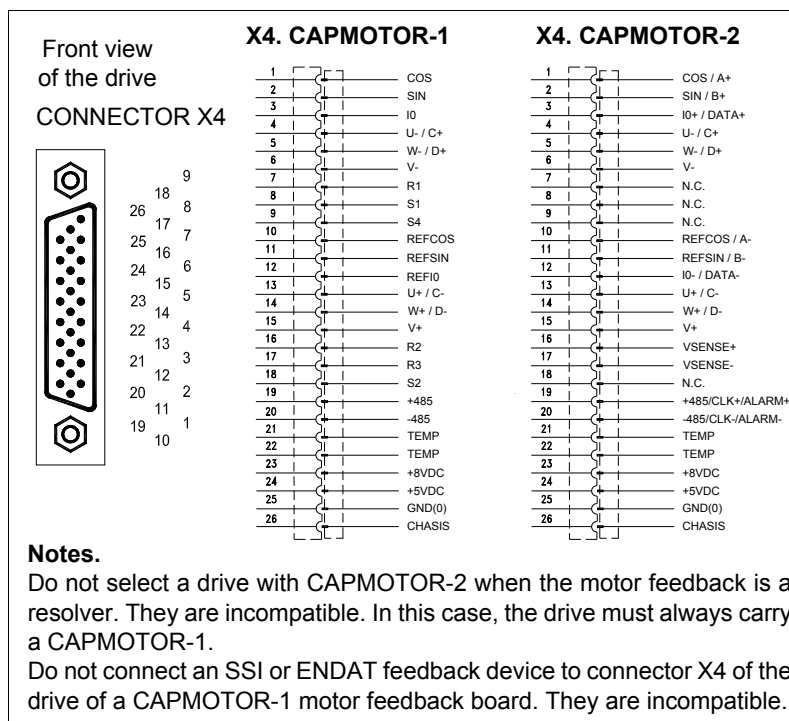

#### F. H3/128

Connector X4. Feedback on the motor. CAPMOTOR-1 or CAPMOTOR-2

**NOTE.** To know whether your drive has a CAPMOTOR-2 installed, check the label on the side of the drive and see if the last field of the sales reference is a B. If not, it will have a CAPMOTOR-1.

The feedback of FAGOR motors use sinusoidal encoder, incremental TTL encoder or resolver. Refer to the corresponding motor manual for the detailed description of the pinout of the feedback devices that can go with each motor family.

With CAPMOTOR-2, this connector supports the following signals:

- Square single-ended TTL
- 1 Volt peak-to-peak sinusoidal (1 Vpp)
- SSI
- EnDat

with the following working frequencies:

- 1 MHz with square signals
- 500 kHz with sinusoidal signals

The input impedance for sinusoidal signals is 120 Ω.

**NOTE.** The characteristics of the signals are the same as the ones described in the previous chapter for the incremental and absolute feedback devices.



DDS  
HARDWARE

Ref.1310

**X5 connector**

**X5. RS-232 serial line**

Connector for the RS-232 serial line board that may come on compact drives. It is a 9-pin male sub-D connector for RS-232 serial connection to a PC in order to set the module configuration parameters and to adjust it.

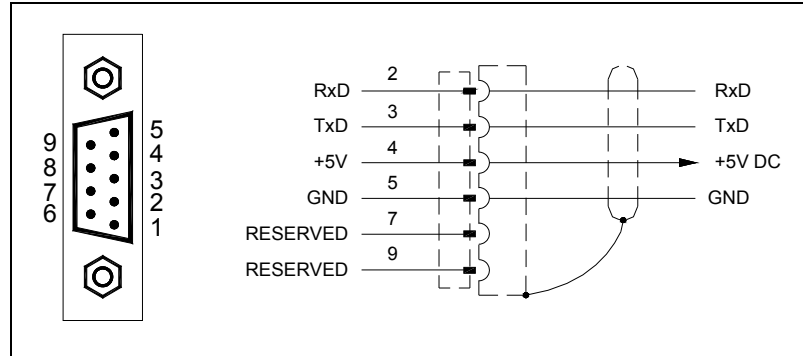

**F. H3/129**

Connector X5. RS-232 serial line.

The description of the pins of this connector is:

**T. H3/25** Description of the pins of connector X5.

(\*) Reserved pins must not be connected.

<b>1</b>	N.C.	Not connected
<b>2</b>	R x D	Receive data
<b>3</b>	T x D	Transmit data
<b>4</b>	+ 5 V	Supply outputs
<b>5</b>	GND	Reference 0 V
<b>6</b>	N.C.	Not connected
<b>7</b>	N.C.	(*) Reserved
<b>8</b>	N.C.	Not connected
<b>9</b>	N.C.	(*) Reserved
<b>CH</b>	CHASSIS	Cable shield

**X6 connector**

This connector of the compact drive identified as X6 may be:

- A SERCOS interface connector.
- A CAN interface connector.
- An RS-232/422 serial line connector (only on CMC drives).

**X6. SERCOS**

This connector consists of a SERCOS signal receiver and emitter (Honeywell IN, OUT) and may be used to connect the modules of the DDS system with the CNC that governs them. The connection is made through fiber optic lines and it has a ring structure.

It will always come with a node selecting rotary switch (Node Select) that lets identify each drive within the system.

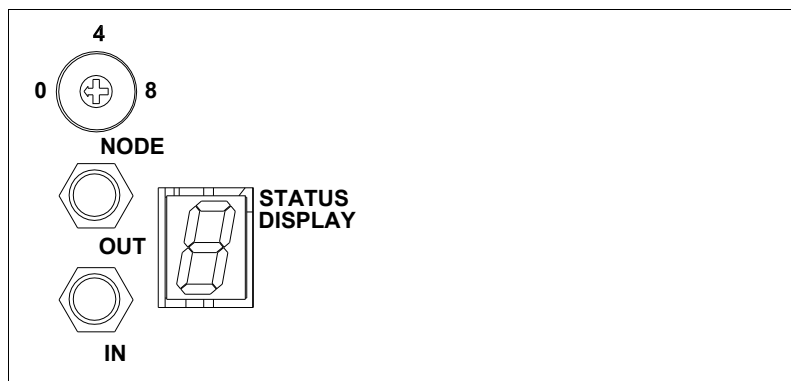

**F. H3/130**

Honeywell emitter-receiver for SERCOS transmission.



**INFORMATION.** Note that on compact drives ACD, SCD and CMC, this connector will always come with connector X5.

**X6. CAN**

5-pin female connector where only three pins are connected CANL(2), SHIELD (3) and CANH (4) and may be used to connect the module of the DDS system with the CNC or another master element (ESA panel) that governs them.

The connection is made with a CAN cable and it has a field bus network type structure. It will always come with a node selecting rotary switch (NODE SELECT) that lets identify each drive within the system.

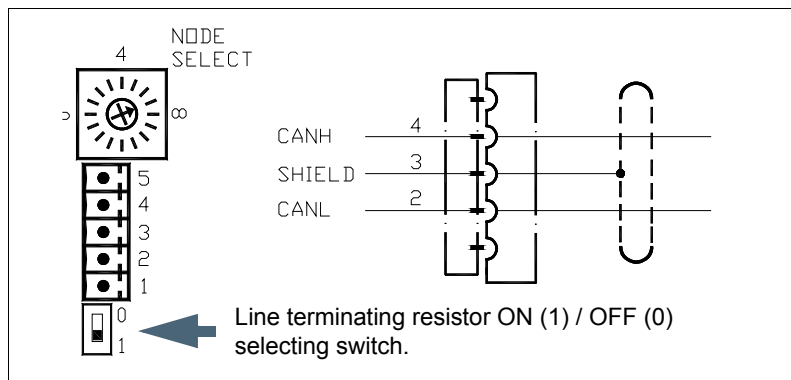

**F. H3/131**

CAN interface connector.



DDS  
HARDWARE

Ref.1310

# 3.

**DRIVE MODULES**  
Compact drives



The description of the pinout of this connector is:

**T. H3/26** Description of the pinout of connector X6 (CAN interface).

1	GNDa	N.C. (not connected)
2	CANL	CAN L bus line
3	SHIELD	Overall shield
4	CANH	CAN H bus line
5	SHIELD	N.C. (not connected)

**INFORMATION.** Note that on compact drives ACD, SCD and CMC, this connector will always come with connector X5.

**X6. RS-232/422 serial line connector**

**NOTE.** Only CMC compact drives can have this connector.

It is a 9-pin male sub-D connector for connecting an RS-232/422 serial line with a device acting as master. This device is usually a PC or an ESA video terminal (VT).

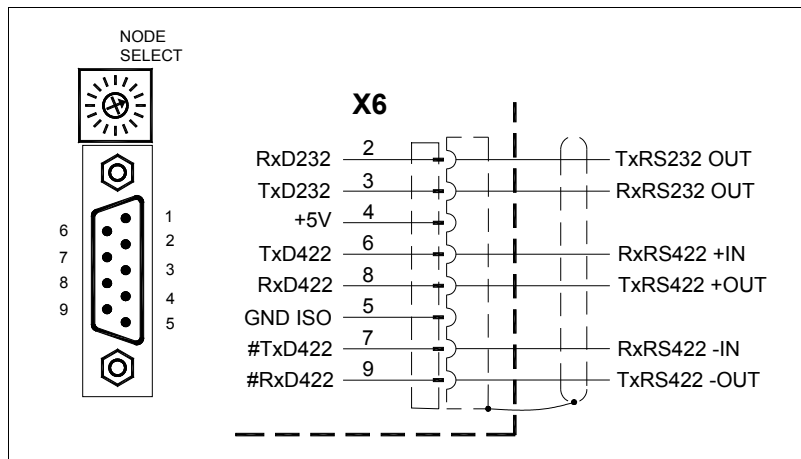

**F. H3/132**

RS-232/422 serial line connector X6.



**INFORMATION.** Note that on compact drives, only the CMC models can have this RS-232/422 connector and only when they do not have the connector X5.

The description of the pins of this connector is:

**T. H3/27** Description of the pins of the RS-232/422 connector.

1	N.C.	Not connected
2	R x D 232	RS-232 serial line data reception
3	T x D 232	RS-232 serial line data transmission
4	+ 5 V ISO	Supply outputs
5	GND ISO	Reference 0 V
6	T x D 422	RS-422 serial line data transmission
7	#T x D 422	
8	R x D 422	RS-422 serial line data reception
9	#R x D 422	
CH	CHASSIS	Cable shield



DDS  
HARDWARE

Ref.1310

**X7 connector**

**X7. Status of the safety relay**

Connector of the compact drive associated with the second contact (**N.C.**, **N**ormally **C**losed) of an internal safety relay (with guided contacts). The status of the relay (initially closed) may be acknowledged through the two pins and a CNC, PLC or control panel, i.e. that the relay has actually opened or closed. These two terminals are identified at the drive as AS1-AS2. The opening or closing of this relay depends on whether 24 V DC are present or not at pin 2 "Drive Enable" of control connector X2. For further detail on this connector, see **9.2. Interface** section of chapter **9. FUNCTIONAL SAFETY** in this manual.

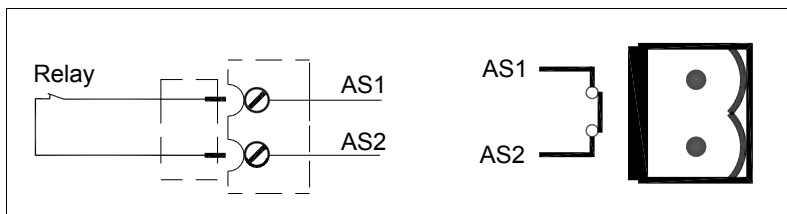

**F. H3/133**

Connector X7. External acknowledgment of the status of the safety relay.

The following table shows the values for gap, tightening torque, sections and other data of the aerial plug-in connector for X7:

**T. H3/28** Data of the pins of plug-in connector for X7.

	<b>ACD/SCD/CMC</b>	<b>SCD</b>
	<b>1.08/1.15/1.25/2.35/2.50</b>	<b>2.75</b>
<b>Connector data</b>		
Nr of poles	2	2
Gap (mm)	5.00	5.00
Min/max tightening torque (Nm)	0.5/0.6	0.5/0.6
Screw thread	M3	M3
Min./max. section (mm <sup>2</sup> )	0.2/2.5	0.2/2.5
Rated current I <sub>n</sub> (A)	12	12
<b>Wire data</b>		
Length to strip (mm)	7	7

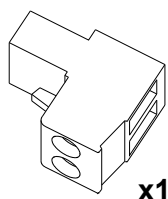

**3.**  
**DRIVE MODULES**  
 Compact drives



**DDS  
 HARDWARE**

**Ref.1310**

# 3.

**DRIVE MODULES**  
Compact drives

## Connectors at slots SL1 and SL2

### CARD A1

The A1 card must always be in slot SL1.

### X6-DIGITAL I/O, digital inputs and outputs

It offers 4 digital inputs and 4 digital outputs, all of them fully programmable.

The digital inputs are optocoupled and referred to a common point (pin 5). The digital outputs are contact type and also optocoupled.

Each input and output is associated with a parameter. The user may assign to these parameters, internal Boolean type variables that may be used to show the system status via electrical contacts.

See "man\_dds\_soft.pdf" manual.

These assigned Boolean variables are set with the monitor program for PC (WinDDSetup).

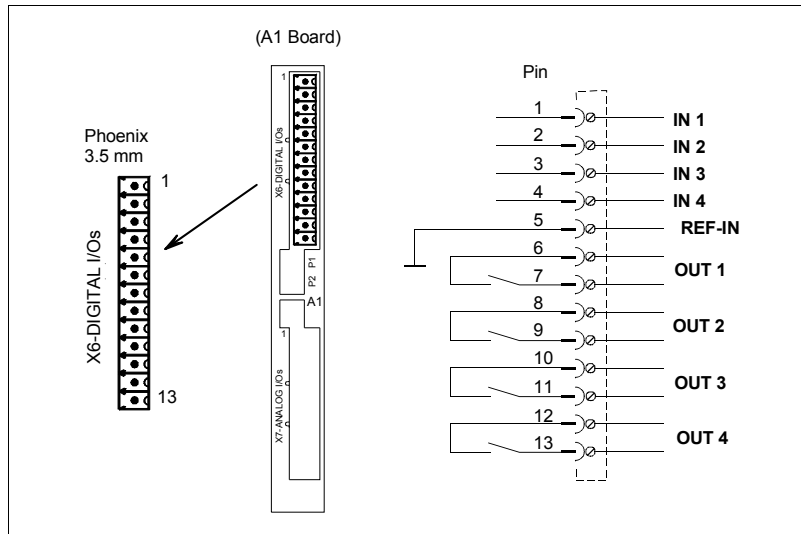

### F. H3/134

A1 card: X6-DIGITAL I/Os. Digital inputs and outputs.

#### Digital inputs characteristics

Maximum rated voltage	24 V DC (36 V DC)
ON/OFF voltage	18 V DC (5 V DC)
Maximum typical consumption	5 mA (7 mA)

#### Digital outputs characteristics

Maximum voltage	250 V
Maximum load current (peak)	150 mA (500 mA)
Maximum internal resistance	24 Ω
Galvanic isolation voltage	3750 V (1 min)



DDS  
HARDWARE

Ref.1310

### X7-ANALOG I/O, digital inputs and outputs

It offers 2 inputs and 2 outputs , all of them fully programmable.

Each input and output is associated with a parameter.

See “man\_dds\_soft.pdf” manual.

It offers a ± 15V power supply for generating a command easily.

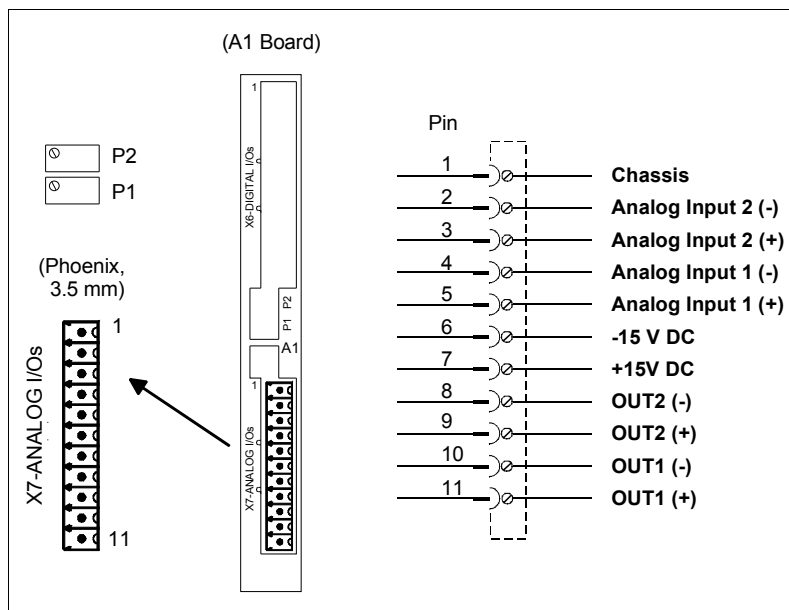

#### F. H3/135

A1 card: X7- ANALOG I/Os. Analog inputs and outputs.

#### Pinout

**T. H3/29** Description of the pins of connector X7-ANALOG I/O. Analog inputs and outputs.

1	Chassis
2	Analog input 2 ( - )
3	Analog input 2 ( + )
4	Analog input 1 ( - )
5	Analog input 1 ( + )
6	Adjustment output (-15 V DC) (user)
7	Adjustment output (+15 V DC) (user)
8	Reference for analog output 2 ( - )
9	Analog output 2 ( + )
10	Reference for analog output 1 ( - )
11	Analog output 1 ( + )

#### Analog input 1

Associated with pins 4 and 5. It is the usual input for the velocity command (± 10 V DC) generated by the CNC.

#### Analog input 2

Associated with pins 2 and 3. It is the auxiliary command input.

#### Analog input characteristics

Resolution	1.22 mV	
Input voltage range	±10 V DC	
Input over-voltage	Continuous mode	80 V DC
	Transients	250 V DC
Input impedance	With respect to GND	40 kΩ
	Between both inputs	80 kΩ
Voltage in common mode	20 V DC	

**3.**  
DRIVE MODULES  
Compact drives



DDS  
HARDWARE

Ref.1310

**Dip-Switches (DS1, DS2)**

**3.**

**DRIVE MODULES**  
Compact drives

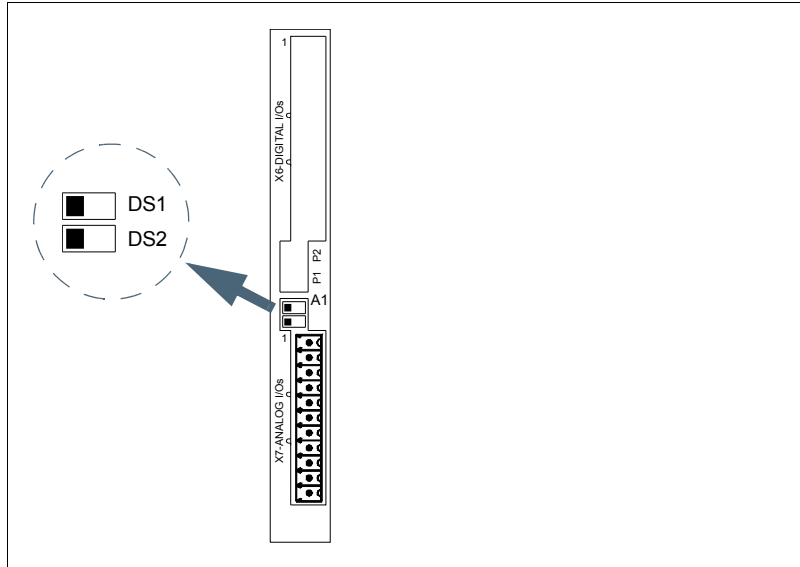

**F. H3/136**

Factory settings of the dip-switches (DS1, DS2).



**MANDATORY.** The operator must not change the state of the dip-switches (DS1, DS2) located on the left when looking at the front of the unit.

**Adjustment outputs**

With these outputs and a potentiometer, the user can obtain a variable analog voltage for adjusting the servo system during setup.

The voltage, with no load, at these pins is  $\pm 15$  V DC.

The electrical circuit necessary to obtain a reference voltage and the recommended resistance values to obtain an approximate range of  $\pm 10$  V DC for the  $V_{ref}$  are described next:

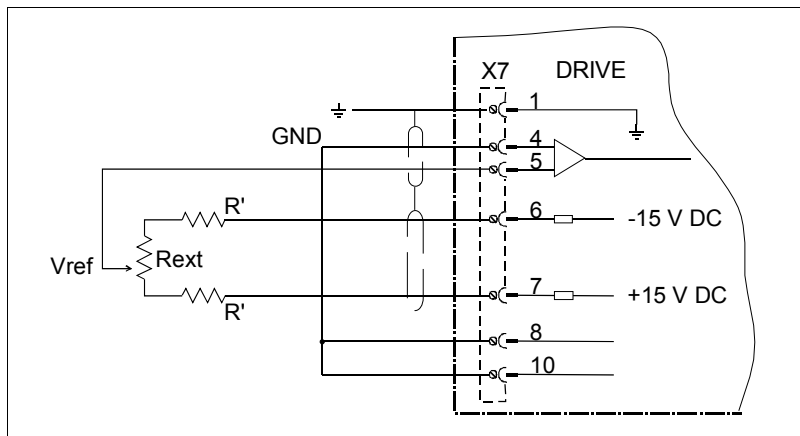

**F. H3/137**

Adjustment outputs.

Range $\pm 10$ V	
Rext.	R'
1 k $\Omega$	0 $\Omega$
5 k $\Omega$	820 $\Omega$
10 k $\Omega$	1.8 k $\Omega$
20 k $\Omega$	3.3 k $\Omega$



DDS  
HARDWARE

Ref.1310

**Analog outputs**

Associated with pins 8-9 and 10-11. These outputs provide an analog voltage indicating the status of the internal system variables. They are especially designed as permanent monitoring of these internal variables and also to be connected to an oscilloscope to make it easier to set the system up.



**INFORMATION.** Note that if the output current is high, the voltage range may decrease.

**Analog output characteristics**

Resolution	4.88 mV
Voltage range	± 10 V DC
Maximum current	± 15 mA
Impedance (respect to GND)	112 Ω

**3.**

**DRIVE MODULES**  
Compact drives

**FAGOR** 

**DDS  
HARDWARE**

**Ref.1310**

# 3.

**DRIVE MODULES**  
Compact drives

### CARDS 8DI-16DO and 16DI-8DO

These cards may be located in slot SL1 and/or SL2.

- 8DI-16DO offers to the user 8 digital inputs and 16 outputs
- 16DI-8DO offers to the user 16 digital inputs and 8 outputs

### X8-DIG.INs, X11-DIG.INs, X12-DIG.INs, digital inputs

They offer 8 fully programmable digital inputs.

The digital inputs are optocoupled and referred to a common point (pin 1) and they admit digital signals at 24 V DC.

Each input is associated with a PLC resource.

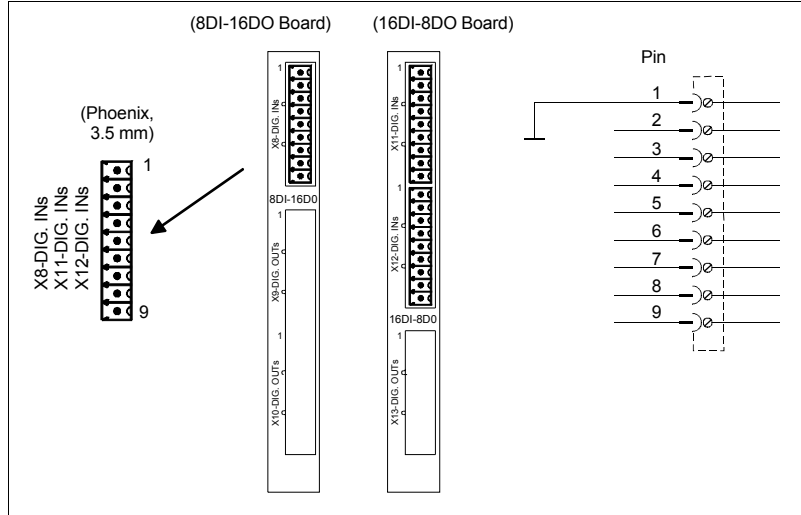

**F. H3/138**

Cards 8DI-16DO and 16DI-8DO.  
X8-DIG. INs, X11-DIG. INs and X12-DIG. INs. Digital inputs.

### Characteristics of the digital inputs (at 24 V)

Rated voltage (maximum)	24 V DC (40 V DC)
ON/OFF voltage	12 V DC / 6 V DC
Typical consumption (max)	5 mA (7 mA)

### X9-DIG. OUTs, X10-DIG. OUTs, X13-DIG. OUT, digital outputs

They offer 8 fully programmable digital outputs. These outputs are optocoupled and of the contact type referred to a common point (pin 1) . Each output is associated with a PLC resource.

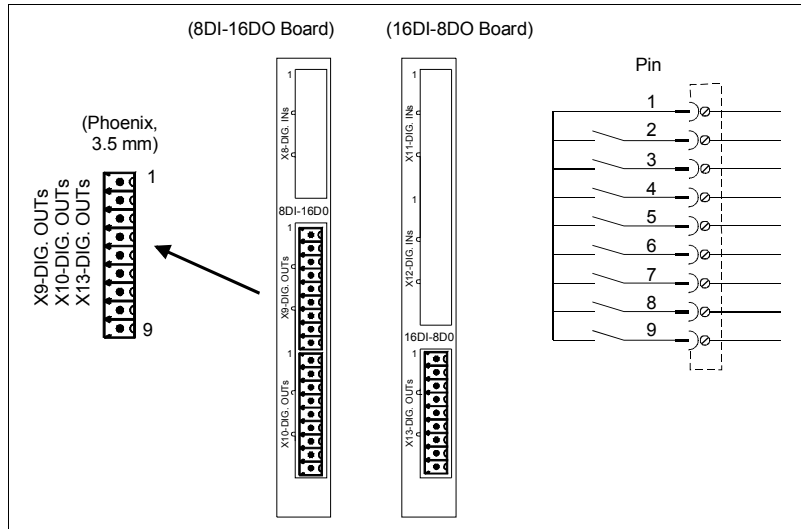

**F. H3/139**

Cards 8DI-16DO and 16DI-8DO.  
X9-DIG. OUTs, X10-DIG. OUTs and X13-DIG. OUTs. Digital outputs.



DDS  
HARDWARE

Ref.1310

**Digital outputs characteristics**

Maximum voltage	250 V
Maximum load current	150 mA
Current autosupply	200 mA
Maximum internal resistance	20 Ω
Galvanic isolation voltage	3750 V (1 min)

**Names of the PLC resources**

Inserting the cards in slots SL1 and SL2 permits all the possible combinations except for two A1 type cards.

At the PLC, the input / output resources can be named according to their location in SL1 and/or SL2:

- ❑ The card inserted in slot SL1 numbers the pins from I1 and O1 on.
- ❑ The card inserted in slot SL2 numbers the pins from I17 and O17 on.
- ❑ The resources are numbered from top to bottom.

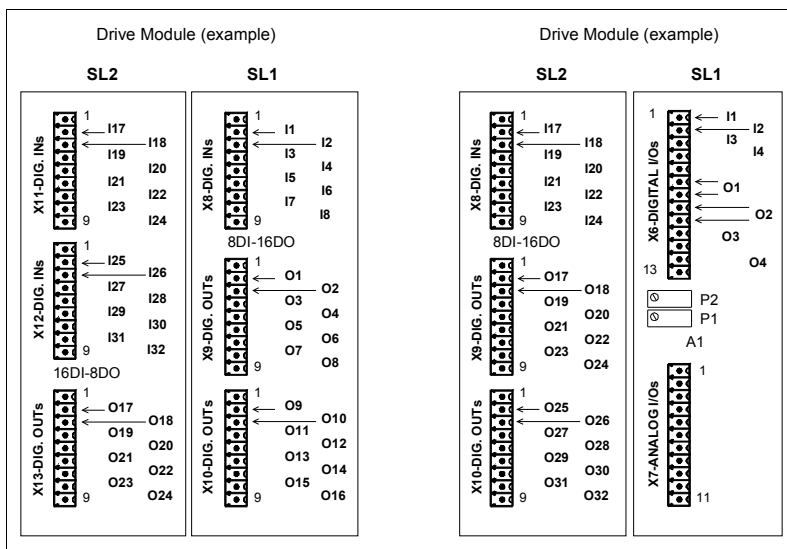

**F. H3/140**

PLC resources on cards located in SL1 and SL2.

**3.**

**DRIVE MODULES**  
Compact drives



**DDS  
HARDWARE**

Ref.1310

### 3.3 Turning a drive on

**3.**  
**DRIVE MODULES**  
Turning a drive on

When powering up the DDS module or doing a reset, various messages appear on the seven - segment display:

1. Initialization stages: they show values of 1, 2, 3 and 4.
2. Software version, after the r with the identifying digits.
3. Error listing.
4. Warning listing.
5. Return to step 3.

Stages shown on the 7-segment display:

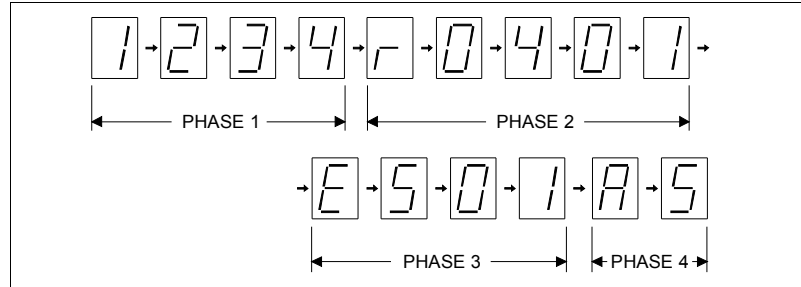

**F. H3/141**

Module startup stages.

Its purpose is to verify that the startup stages are being executed properly. The information sequences that it is showing in the start-up process have the following meaning:

1. Initialization stage: After the display is turned off, digits 1, 2, 3 and 4 <sup>(a)</sup> are shown which correspond to the 4 initialization stages. The display then turns back off.

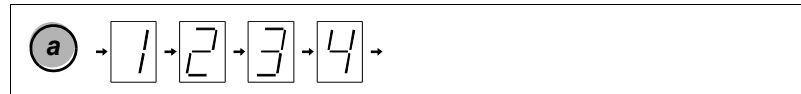

**F. H3/142**

Initialization stage. STAGE 1.

2. Software version displaying stage: It shows the software version loaded in the module. It first shows the letter r (indicating the version “release”), followed by the version number (digit by digit) <sup>(b)</sup>. When the drive is active and the axis is being governed, the display will show the zero digit with a blinking dot <sup>(c)</sup>.

While loading parameters, the display only shows the middle segment <sup>(e)</sup>.

When the drive (in a system with SERCOS interface) is not in stage 4, i.e. the system communication between the CNC and the modules has not finished initializing and although the light ring is closed, it has not gone up to the next stage, the display shows a smaller fixed zero <sup>(d)</sup> (not blinking).

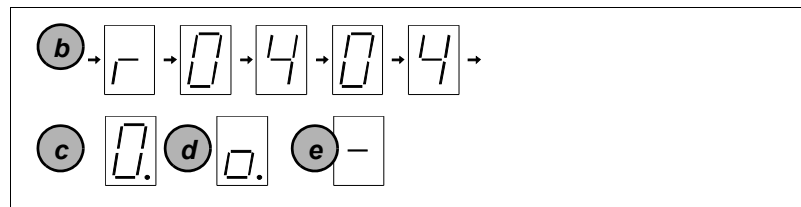

**F. H3/143**

Stage to display the software version and other indications

If this zero (smaller) is not fixed (blinks) it means that the light ring is not closed (the light does not reach) or there is too much distortion.

This indication permits detecting which section of the optical fiber is causing the problem (or which drive is not sending light).

Hence, the module whose display blinks this smaller zero is the one that is not receiving light at the input.



DDS  
HARDWARE

Ref.1310

3. Final stages: They display error messages or warnings on the display when they come up. When the series ends, it begins a new sequence again repeating these messages again.

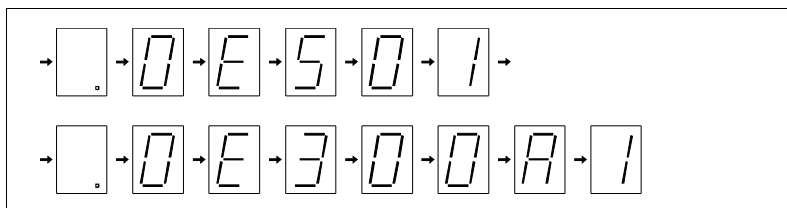

#### F. H3/144

Final stages. Error and warning displaying STAGES.

See the meaning of errors codes and warnings that may be shown on the display of the drive in chapter 14. **ERROR CODES AND MESSAGES**, of the “man\_dds\_soft.pdf” manual.



**INFORMATION.** The CNC screen also shows these codes and error messages as well as the codes and texts of SERCOS or CAN communication errors.

With analog interface, the code of the activated error is only displayed on the display of the drive.

The system will not start running until all the errors detected at the drive have been eliminated.

To eliminate these errors, their cause has to have disappeared and, then an < error reset > must be carried out. This <reset> may be activated from connector X2 (pin 1) of the power supply module (with modular drives) or from connector X2 (pin 3) of the compact drive.

**NOTE.** Remember that there are errors classified as “non-resettable” that cannot be eliminated with this method. These errors can only be eliminated by turning the unit off and back on and only if the cause of the error has been eliminated. See the section “non-resettable errors” in chapter 14 of the “man\_dds\_soft.pdf” manual.

For further information on initialization and error reset, see the corresponding section of this chapter.

**NOTE.** Remember that the errors may be disabled from the “error disable” tab of the “SPY” window of the WinDDSSetup application. For further detail, see chapter 16. **WINDDSSSETUP** of the “man\_dds\_soft.pdf” manual.

If the system uses CAN interface, the display will show the stages mentioned earlier like when using SERCOS interface, with a fixed zero when it is operative or with a smaller fixed or intermittent zero when receiving or not a response to the first message sent out on power-up.

# 3.

**DRIVE MODULES**  
Turning a drive on

**FAGOR** 

**DDS  
HARDWARE**

**Ref.1310**



Besides the power supplies and the drive modules that make up the FAGOR DDS servo drive system, there is a set of auxiliary modules that are also part of the system and are used to perform a specific function.

Hence, we refer to:

## □ Mains filters

MAINS FILTER □□A
------------------

## □ Chokes

Choke XPS-25
Choke XPS-65 (discontinued), Choke XPS-65-A
Choke RPS-75-3
Choke RPS-45
Choke RPS-20

## □ Resistor modules

External resistors ER+TH-□/□ with thermostat
External resistors ER+TH-18/□+FAN with thermostat and fan

## □ Capacitor module

CM 1.60
---------

## □ Auxiliary power supply module

APS-24
--------

The following sections analyze all of them showing their technical characteristics and other considerations.

## 4.1 Mains filters

In order to comply with European Directive 2004/108/EC on Electromagnetic Compatibility, it is mandatory to insert a mains filter. Particularly, the standard IEC 61800-3 for category C3 and the standard IEC 61326-3-1 for immunity.

The mains filters of the FAGOR catalog are referred to as MAINS FILTER xA.

They are installed between mains and the DDS servo system (modular or compact) in order to reduce conducted disturbances caused by the drive down to the levels indicated by the standard mentioned earlier and, at the same time, make it immune to transient over-voltage like bursts or voltage pulses.

### MAINS FILTER xA. Technical data



#### F. H4/1

Mains filters.

#### T. H4/1 Technical data.

MAINS FILTER	42A	130A	180A
Rated voltage	3 phases: 380 V AC - 480 V AC (50/60 Hz)		
Rated current (rating @ 50°C/122°F)	42 A	130 A	180 A
Approximate mass	2.8 kg / 6.2 lb	7.5 kg / 16.5 lb	11 kg / 24.2 lb
Rated leak current	0.50 mA	0.75 mA	0.75 mA
Max. leak current	27 mA	130 mA	130 mA
Power loss	19 W	40 W	61 W
Sealing	IP 20	IP 20	IP 20

#### T. H4/2 Technical data of the connection terminals.

MAINS FILTER	42A	130A	180A
Max. tightening torque (Nm)	1.8	8	18
Terminals min./max. section (mm <sup>2</sup> )	1/10	16/50	35/95



**INFORMATION.** Note that this filter must be mounted near the drive.

Chapter 6. **POWER LINE CONNECTION** shows the strict rules that must be followed to properly install the mains filters. Chapter 11. **DIMENSIONS** of this manual shows the dimensions.

## 4.2 Chokes

The chokes (inductances or coils) are used with regenerative power supplies (XPS-25 and XPS-65) and regenerative regulated power supplies (RPS-80, RPS-75, RPS-45 and RPS-20).

When returning power to mains, the impedance of mains for the outgoing currents is very low. Hence, the up ramps of this current must be limited with a choke.

These three-phase chokes for XPS and RPS power supplies must be connected to the power line input.

On the XPS power supplies, the choke must be connected to power terminals CH1 and CH2 located at the bottom of the module.

RPS power supplies do not have connection terminals at the bottom of the module like at XPS power supplies; therefore, it must be connected to the power line between the MAINS FILTER □□A and the RPS power supply itself. See diagrams in the corresponding chapter of this manual.

The internal switching mechanism of these power supplies generates a regenerative current to mains already filtered by this choke.

FAGOR provides the XPS-25 and XPS-65-A chokes that must necessarily go with the corresponding XPS power supplies and the RPS-75-3, RPS-45 and RPS-20 chokes that must go with RPS power supplies.

### XPS chokes. Technical data

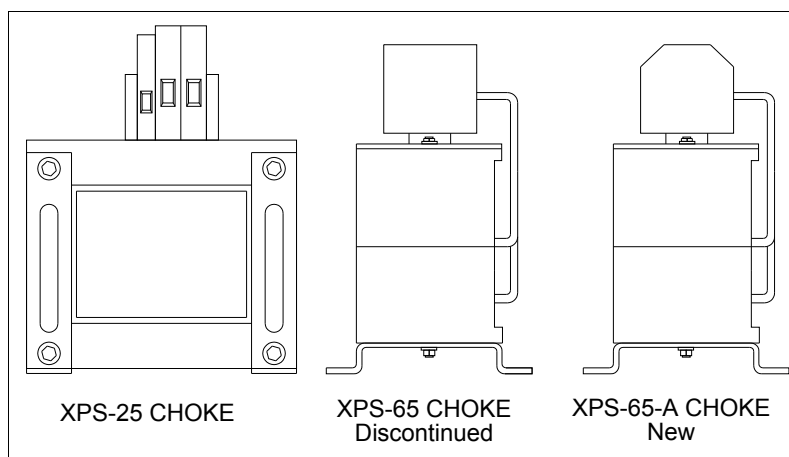

### F. H4/2

XPS CHOKES.

### T. H4/3 Technical data.

CHOKE	XPS-25	XPS-65 DISCONTINUED	XPS-65-A NEW
Inductance (10 kHz)	0.350 mH	0.175 mH	0.250 mH
Rated current	50 A	120 A	120 A
Peak current	100 A	180 A	185 A
Max. terminal section	10 mm <sup>2</sup>	50 mm <sup>2</sup>	70 mm <sup>2</sup>
Approximate mass kg (lb)	8.0 (17.6)	22.5 (49.3)	36.0 (79.3)
Operating amb. temperature	5°C to 45°C (41°F to 113°F)		
Storage temperature	- 20°C to + 60°C (- 4°F to 140°F)		
Relative humidity	80 % max.		
Operating vibration	0.5 G		
Shipping vibration	2 G		
Sealing	IP 20		

# 4.



**MANDATORY.** The use of these chokes is a must for the proper operation of the XPS regenerative power supplies. The length of the cable joining the choke with the power supply must never exceed 2 meters.

# 4.

AUXILIARY MODULES  
Chokes

Chapter **6. POWER LINE CONNECTION** shows the strict rules that must be followed to properly install the chokes. Chapter **11. DIMENSIONS** of this manual shows the dimensions.

**RPS chokes. Technical data**

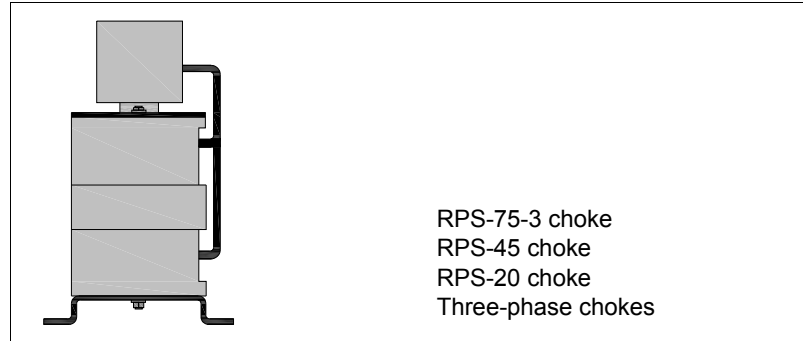

**F. H4/3**

RPS chokes.

**T. H4/4** Technical data.

CHOKE	RPS-20	RPS-45	RPS-75-3
Inductance (8 kHz )	0.90 mH	0.40 mH	0,175 mH
Rated current	32 A	72 A	120 A
Max current	50 A	125 A	180 A
Min. cable section	10 mm <sup>2</sup>	35 mm <sup>2</sup>	70 mm <sup>2</sup>
Approx. mass kg / lb	12.7 / 28.0	20.4 / 44.9	36.0 / 79.3
Operating ambient temp.	0 °C to 60 °C (32 °F to 140 °F)		
Storage temperature	- 20 °C to 60 °C (- 4 °F to 140 °F)		
Relative humidity	< 90 % non condensing at 45 °C (113 °F)		
Operating vibration	0.5 G		
Shipping vibration	2 G		
Sealing	IP 20		



**MANDATORY.** Installing chokes is an absolute must when using RPS regenerative regulated power supplies and they must always be installed between the power supply and the mains filter. The length of the cable joining each choke with the power supply must never exceed 2 meters and must be shielded.

Chapter **6. POWER LINE CONNECTION** shows the strict rules that must be followed to properly install the chokes. Chapter **11. DIMENSIONS** of this manual shows the dimensions.



DDS  
HARDWARE

Ref.1310

### 4.3 External Ballast resistors

**NOTE.** This manual uses two synonyms “external Ballast resistors” and “Crowbar resistors” to refer to external braking resistors.

External resistors are used to dissipate the excess of energy generated at the power bus in a braking process of electrical motors and cannot be dissipated by the internal resistor of the module (power supply or compact drive). These resistors do not require external electrical supply.

#### ER+TH-x/x resistors with thermostat. Technical data

Independent resistors whose reference is ER+TH-□/□ are external electrical resistors used with power supplies and compact drives that have an internal or external thermostat.

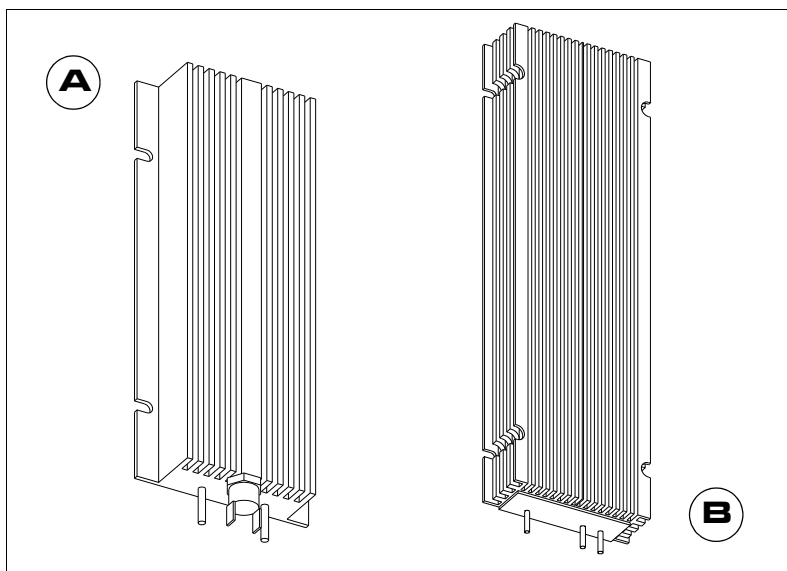

**F. H4/4**

External Ballast resistors:

**A.** with external thermostat, **B.** with internal thermostat.

#### T. H4/5 External Ballast resistor with external thermostat. Technical data.

With external thermostat	ER+TH -24/750	ER+TH -24/1100	ER+TH -18/1100
Resistor	24 Ω	24 Ω	18 Ω
Tolerance	± 5%	± 5%	± 5%
RMS power	650 W	950 W	950 W
Energy absorbed in 5" overloaded	37 kJ	55 kJ	55 kJ
Operating ambient temperature	5 °C to 45 °C (41 °F to 113 °F)		
Storage temperature	- 20 °C to 60 °C (- 4 °F to 140 °F)		
Relative humidity	< 90 % non condensing at 45 °C (113 °F)		
Operating vibration	0.5 G		
Shipping vibration	2 G		
Sealing degree	IP 55		
Approx. mass gr / lb	920 / 2.02	1250 / 2.75	1250 / 2.75

*Note that the value for the rms power depends on the following conditions: Resistor installed vertically with the connection cables at the bottom and separated from the nearest surface at a distance of at least 10 cm (about 4 inches).*



**WARNING.** Careful with the surface of these resistors. Remember that its temperature may reach 400 °C (752 °F).

4.

AUXILIARY MODULES  
External Ballast resistors



DDS  
HARDWARE

Ref.1310

**4.**

**AUXILIARY MODULES**  
External Ballast resistors

**T. H4/6** External Ballast resistor with internal thermostat. Technical data.

With internal thermostat	ER+TH-18/1800	ER+TH-18/2200
Resistor	18 Ω	18 Ω
Tolerance	± 5%	± 5%
RMS power	1300 W	2000 W
Energy absorbed in 5" overloaded	55 kJ	83 kJ
Operating room temperature	5 °C to 45 °C (41 °F to 113 °F)	
Storage temperature	- 20 °C to 60 °C (- 4 °F to 140 °F)	
Relative humidity	< 90 % non condensing at 45 °C (113 °F)	
Operating vibration	0.5 G	
Shipping vibration	2 G	
Sealing	IP 54	IP 54
Approx. mass kg/lb	3.0 / 6.61	7.0 / 15.43

*Note that the value for the rms power depends on the following conditions: Resistor installed vertically with the connection cables at the bottom and separated from the nearest surface at a distance of at least 10 cm (about 4 inches).*



**WARNING.** Careful with the surface of these resistors. Remember that its temperature may reach 410 °C (770 °F).

Chapter **8. INSTALLATION** shows the installation rules for external braking resistors that must be followed strictly in order to install them properly. Chapter **11. DIMENSIONS** of this manual shows their dimensions.



DDS  
HARDWARE

Ref.1310

**ER+TH-18/x+FAN resistors with internal thermostat and fan. Technical data**

The independent resistors whose reference is ER+TH-18/□+FAN are external electrical resistors that can also be used with power supplies and compact drives that have an internal thermostat and a single-phase 220 V AC cooling fan.

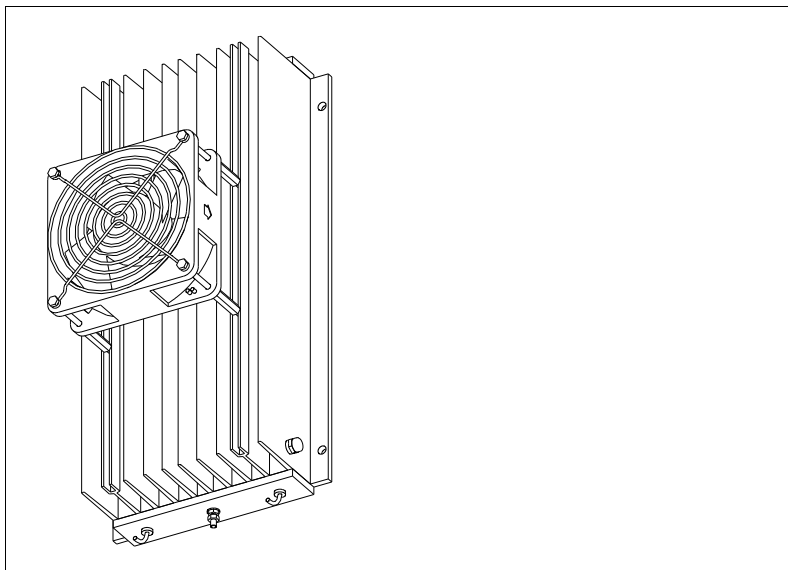

**F. H4/5**

External Ballast resistor with internal thermostat and a fan.

**T. H4/7** External Ballast resistor with internal thermostat and a fan. Technical data.

<b>ER+TH-00/OOOO+FAN</b>	<b>18/1000</b>	<b>18/1500</b>	<b>18/2000</b>
Resistor	18 Ω	18 Ω	18 Ω
RMS power	2.0 kW	3.0 kW	4.0 kW
Operating room temperature	- 10 °C / + 40 °C (14 °F / 104 °F)		
Storage temperature	- 20 °C to 60 °C (- 4 °F to 140 °F)		
Relative humidity	< 90 % non condensing at 45 °C (113 °F)		
Operating vibration	0.5 G		
Shipping vibration	2 G		
Sealing	IP 20 / IP 65*		
Approx. mass kg/lb	6.0 / 13.2	7.0 / 15.4	8.0 / 17.6

\* To maintain a sealing protection of IP 65, the surface temperature of the resistor must not exceed 200 °C / 392 °F.



**WARNING.** Careful with the surface of these resistors. Remember that its temperature may exceed 300 °C (572 °F).

Chapter **8. INSTALLATION** shows the installation rules for external braking resistors that must be followed strictly in order to install them properly. Chapter **11. DIMENSIONS** of this manual shows their dimensions.

**4.**

**AUXILIARY MODULES**  
External Ballast resistors



**DDS  
HARDWARE**

**Ref.1310**

**4.**

**AUXILIARY MODULES**  
External Ballast resistors

**Thermostats associated with external resistors. Technical data**

All external Ballast resistors currently available in the FAGOR catalog come with a thermostat. They are classified as:

Thermostat	Reference of the external Ballast resistor
Internal	ER+TH-18/1800, ER+TH-18/2200 ER+TH-18/1000+FAN, ER+TH-18/1500+FAN, ER+TH-18/2000+FAN
External	ER+TH-24/750, ER+TH-24/1100, ER+TH-18/1100

and their technical characteristics are:

Internal thermostat	
Contact person	Normally Closed
Contact opening temperature	160 °C (320 °F) ± 10%
Rated voltage	250 V AC
Rated current	2 A
Wire section	0.25 mm <sup>2</sup>

External thermostat	
Protection degree	IP 20
Contact person	Normally Closed
Contact opening temperature	200 °C (320 °F) ± 10%
Rated voltage	250 V AC
Rated current	2.5 A
Wire section	0.25 mm <sup>2</sup>

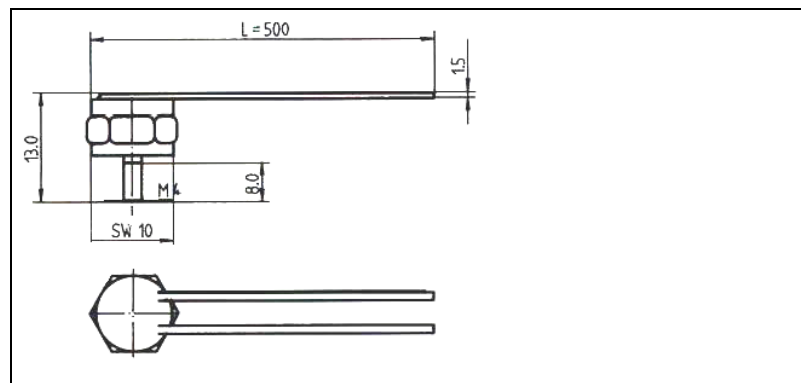

**F. H4/6**

External thermostat.

**Ohm value**



**WARNING.** When connecting an external braking resistor other than the one shown in table **T. H4/8** make sure that its Ohm value is the same as that of the internal Ballast resistor of the unit. Verify it in the technical characteristics table of the corresponding power supply in chapter 2 or of the corresponding compact drive in chapter 3 of this manual.

ACD/CMC/SCD compact units **without NR reference** have a particular resistor associated with them; FAGOR supplies it in an accessory bag inside the unit package and the user must install it. This is not the case for units **with NR reference** for which the user must select the appropriate resistor model depending on the energy to be dissipated in the application. Therefore, the latter do not come with the resistor in the accessory bag of the unit and it must be requested separately.

**4.**

**AUXILIARY MODULES**  
External Ballast resistors

Use the attached table to select the external Ballast resistor for your power supply with enough rms power to dissipate the energy generated while braking.

**T. H4/8** Possible braking resistors to be installed on power supplies. Required Ohm values.

<b>PS-25B4</b>	18 Ω	950 W	ER+TH-18/1100
		1.3 kW	ER+TH-18/1800
		2.0 kW	ER+TH-18/2200
		2.0 kW	ER+TH-18/1000+FAN
		3.0 kW	ER+TH-18/1500+FAN
		4.0 kW	ER+TH-18/2000+FAN
<b>XPS-25</b>	18 Ω	950 W	ER+TH-18/1100
		1.3 kW	ER+TH-18/1800
		2.0 kW	ER+TH-18/2200
		2.0 kW	ER+TH-18/1000+FAN
		3.0 kW	ER+TH-18/1500+FAN
		4.0 kW	ER+TH-18/2000+FAN
<b>PS-65A</b>	9 Ω	1.9 kW	2x ER+TH-18/1100 in parallel
		2.6 kW	2x ER+TH-18/1800 in parallel
		4.0 kW	2x ER+TH-18/2200 in parallel
		4.0 kW	2x ER+TH-18/1000+FAN in parallel
		6.0 kW	2x ER+TH-18/1500+FAN in parallel
		8.0 kW	2x ER+TH-18/2000+FAN in parallel
<b>XPS-65</b>	9 Ω	1.9 kW	2x ER+TH-18/1100 in parallel
		2.6 kW	2x ER+TH-18/1800 in parallel
		4.0 kW	E2x R+TH-18/2200 in parallel
		4.0 kW	2x ER+TH-18/1000+FAN in parallel
		6.0 kW	2x ER+TH-18/1500+FAN in parallel
		8.0 kW	2x ER+TH-18/2000+FAN in parallel



**DDS  
HARDWARE**

**Ref.1310**

Use the attached table to select the Ballast resistor for your compact drive module when applicable with enough rms power to dissipate the energy generated while braking.

**T. H4/9** Possible braking resistors to be installed on compact drive modules. Required Ohm values.

<b>ACD 1.15</b>	43 Ω	300 W	Internal R.
<b>CMC 1.15</b>	43 Ω	300 W	Internal R.
<b>SCD 1.15</b>	43 Ω	300 W	Internal R. or external ER+TH-43/350 (with external thermostat)
<b>ACD 1.25</b>	24 Ω	250 W	24Ω 550 W *
<b>CMC 1.25</b>	24 Ω	250 W	24Ω 550 W *
<b>SCD 1.25</b>	24 Ω	650 W	24Ω 750 W * with external thermostat
<b>SCD 1.25...NR</b>	24 Ω	950 W	ER+TH-24/1100
<b>ACD 2.35</b>	18 Ω	450 W	18Ω 900 W *
<b>CMC 2.35</b>	18 Ω	450 W	18Ω 900 W *
<b>SCD 2.35</b>	18 Ω	1.3 kW	18Ω 1800 W * with internal thermostat
<b>SCD 2.35...NR</b>	18 Ω	2.0 kW	ER+TH-18/2200
		2.0 kW	ER+TH-18/1000+FAN
		3.0 kW	ER+TH-18/1500+FAN
		4.0 kW	ER+TH-18/2000+FAN
<b>ACD 2.50</b>	18 Ω	450 W	18Ω 900 W *
<b>CMC 2.50</b>	18 Ω	450 W	18Ω 900W *
<b>SCD 2.50</b>	18 Ω	1.3 kW	18Ω 1800 W * with internal thermostat
<b>SCD 2.50...NR</b>	18 Ω	2.0 kW	ER+TH-18/2200
		2.0 kW	ER+TH-18/1000+FAN
		3.0 kW	ER+TH-18/1500+FAN
		4.0 kW	ER+TH-18/2000+FAN
<b>SCD 2.75</b>	18 Ω	3.0 kW	ER+TH-18/1500+FAN *
<b>SCD 2.75...NR</b>	18 Ω	4.0 kW	ER+TH-18/2000+FAN

\* FAGOR supplies the resistors indicated with an asterisk (see shaded rows) as accessories with the unit. The rest of them are supplied only upon request.

# 4.

## AUXILIARY MODULES

External Ballast resistors



DDS  
HARDWARE

Ref.1310

## 4.4 Capacitor module

This module stores the energy returned while the motors are braking.

The capacitor module should also be used when having systems that sporadically request high current peaks from the power bus hence increasing the bus' own capacity.

From the energy point of view, installing a capacitor module is more efficient than installing external braking resistors.

### Capacitor module, CM 1.60. Technical data

Module that must be connected in parallel to the power DC bus. FAGOR supplies with each module two plates for connecting them to the DC bus.

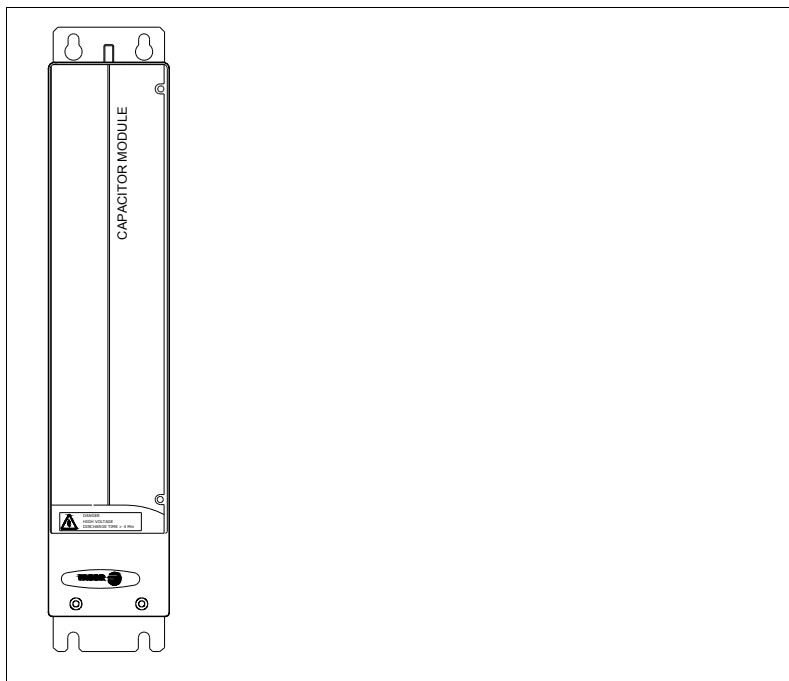

#### F. H4/7

Capacitor module CM 1.60.

#### T. H4/10 Technical data.

Capacitor module	CM 1.60
Capacity	4 mF
Maximum voltage at the bus	797 V DC
Operating ambient temperature	5 °C to 45 °C (41 °F to 113 °F)
Storage temperature	- 20 °C to + 60 °C (- 4 °F to 140 °F)
Relative humidity	< 90% (non condensing at 45°C/11°F)
Operating vibration	0.5 G
Shipping vibration	2 G
Sealing	IP 20
Approx. mass kg/lb	6.0 / 13.2

Chapter 11. **DIMENSIONS** of this manual shows their dimensions.

4.

AUXILIARY MODULES  
Capacitor module

**FAGOR** 

DDS  
HARDWARE

Ref.1310

## 4.5 Auxiliary power supply

The main purpose of the auxiliary power supply module APS-24 is to generate 24 V DC for the control circuits of the drive modules and of the power supplies that do not integrate the auxiliary power supply (i.e. PS-65A). This voltage is supplied through three identical connectors (X2, X3 and X4) connected in parallel that may be accessed from the face of the module. Includes protections against over-current and over-voltage both at the input and at the output.

There is no need to use these power supplies for compact drives, regenerative power supplies (XPS-25, XPS-65, RPS-20, RPS-45, RPS-75 and RPS-80) and the non-regenerative power supply (PS-25B4). They all integrate an auxiliary power supply already with these features. However, an auxiliary power supply may be installed next to the units mentioned here when the required consumption exceeds what the integrated auxiliary power supply can provide. Hence, for example, when there are too many axes connected to the DC bus, there will be too many control circuits, fans etc. to supply power to. In that case, install an external auxiliary power supply that can provide all the required power.

### Auxiliary power supply module, APS-24. Technical data

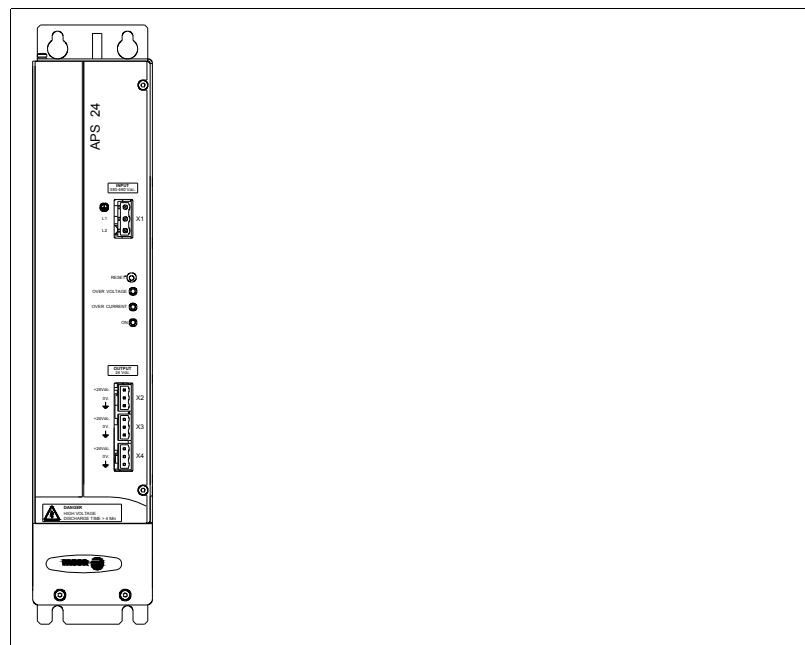

F. H4/8

Auxiliary power supply module, APS-24.

### T. H4/11 Technical data.

Auxiliary pow. supply module	APS-24
Output voltage, max. current	24 V DC (5%), 10 A
Input voltage	400-10% a 460+10% V AC, 50/60 Hz
Mains consumption	0.72 A (400 V AC), 0.63 A (460 V AC)
Max. Inrush current	23.9 A (460 V AC)
Bus consumption	0.48 A (565 V DC), 0.44 A (650 V DC)
Max. voltage at the bus	790 V DC
Operating ambient temperature	5 °C to 45 °C (41°F to 113 °F)
Storage temperature	- 20 °C to + 60 °C (- 4 °F to 140 °F)
Relative humidity	< 90% non condensing at 45 °C (113°F)
Operating vibration	0.5 G
Shipping vibration	2 G
Sealing	IP 20
Approx. mass kg/lb	4.3 / 9.4 lb



**INFORMATION.** In case of micro-surges or total mains power outage, this module guarantees the stability of the 24 V DC to feed the control circuits of the drive modules connected to the bus and maintain it for as long as the emergency stop of the motors lasts, thus stopping the axes in a controlled manner.

**NOTE.** See chapter 13. **COMPATIBILITY** for the references of the compatible APS-24 power supplies with the XPS or RPS power supplies in case it is installed.

**Block diagram**

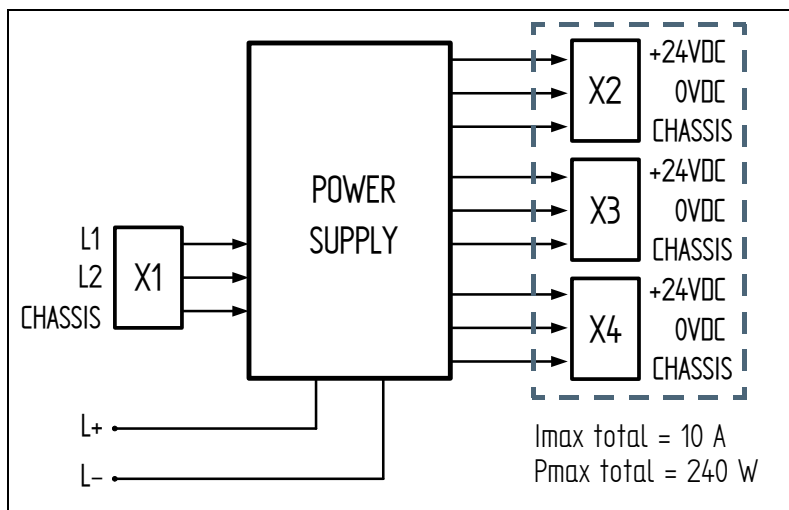

**F. H4/9**

Block diagram of the auxiliary power supply APS-24.

**4.**

**AUXILIARY MODULES**  
Auxiliary power supply



**DDS  
HARDWARE**

**Ref.1310**

### Connectors

The auxiliary power supply APS-24 has the following connectors:

**4.**  
**AUXILIARY MODULES**  
Auxiliary power supply

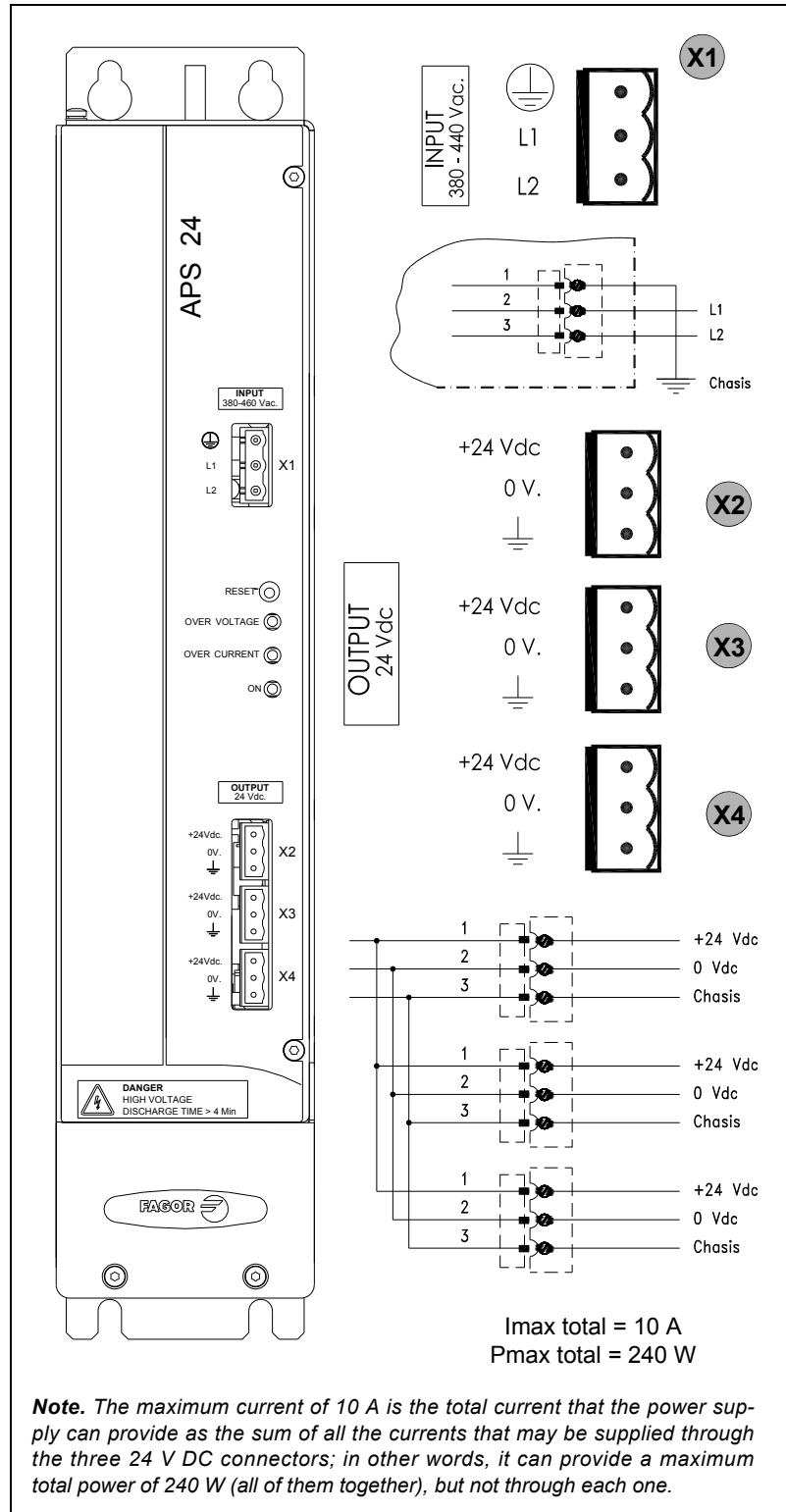

#### F. H4/10

Connectors of the APS-24 power supply.

- X1.** Input connector to feed the auxiliary power supply from mains. It admits a voltage between 400 V AC and 460 V AC.
- X2.** Output connector of the auxiliary power supply offering 24 V DC.
- X3.** Output connector of the auxiliary power supply offering 24 V DC.
- X4.** Output connector of the auxiliary power supply offering 24 V DC.



DDS  
HARDWARE

Ref.1310

### Status indicator lamps

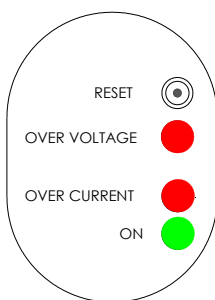

The auxiliary power supply APS-24 has the following indicator lights that inform about its running status.

- ❑ **OVER VOLTAGE.** Red LED. Output over-voltage. It has exceeded 28 V DC and interrupts its operation.
- ❑ **OVER CURRENT.** Red LED. Output over-current. The power supply has exceeded 10 A and its output voltage is less than 24 V DC.
- ❑ **ON.** Green LED. It is working fine.
- ❑ **RESET.** When the power supply quits working due to over-voltage, the RESET button may be used to restart the system.

### Other considerations



**WARNING.** This APS-24 power supply is to be used to supply to the electrical control circuits and signals to run the drive. **This module must never be used to supply power to the brake of a motor.** The brake may generate voltage peaks that could damage the unit.

Chapter **8. INSTALLATION** shows the strict rules that must be followed to properly install the auxiliary power supply. Chapter **11. DIMENSIONS** of this manual shows their dimensions.

## 4.

**AUXILIARY MODULES**  
 Auxiliary power supply



**DDS  
HARDWARE**

**Ref.1310**



## 5.1 Selection of the synchronous motor and its associated drive

### First motor pre-selection

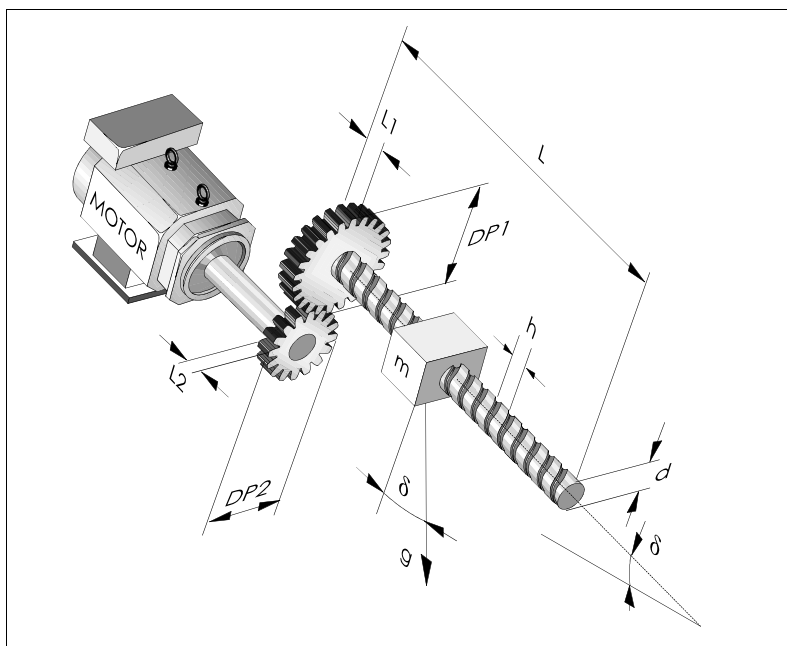

**F. H5/1**

General diagram of a MOTOR - LEADSCREW - TABLE system.

The motor selection will depend on the mechanical and dynamic response characteristics that it must satisfy. Hence, the motor must meet the specifications on torque (Nm), speed, duty cycles or other kind of requirements of the motor to be moved.

#### Calculation of the necessary motor torque (M)

The required total motor torque  $M_T$  has two components:

- The static torque  $M_S$  to maintain the table at a constant speed or fixed in a position.
- The acceleration torque  $M_A$  to change its speed.

The reduction in the motor ballscrew transmission [i] is a factor to be considered in many of the following calculations:

$$M_T = M_S + M_A$$

$$i = \frac{DP1}{DP2}$$

$$M_{TOTAL} = M_{CONTINUOUS} + M_{ACCELERATION}$$

# 5.

SELECTING CRITERIA

Selection of the synchronous motor and its associated drive

- The continuous torque  $M_S$ :

$$M_S = M_F + M_W + M_C$$

$$M_{CONTINUOUS} = M_{FRICTION} + M_{WEIGHT} + M_{CUTTING}$$

is due to:

- the friction between table with its ways and with the ballscrew  $M_F$ ,
- the weight of the table when not moving horizontally  $M_W$ ,
- the cutting force of the tool  $M_C$ .

- Friction torque  $M_F$  :

$$M_F = [M_{F-TABLE} + M_{F-BALLSCREW}] \cdot \frac{1}{i} = \left[ \frac{m \cdot g \cdot \mu \cdot h}{2\pi} + \frac{d}{10} \right] \cdot \frac{1}{i}$$

where:

- $M_F$  Torque due to friction in N·m.
- $m$  Table mass in kg.
- $d$  Leadscrew diameter in m.
- $g$  Gravitational acceleration, 9.81 in m/s<sup>2</sup>.
- $h$  Leadscrew pitch per turn in m.
- $\mu$  The friction coefficient between the table and the ways it moves on:

typical  $\mu$  values depending on material:

Iron	0.1 ÷ 0.2
Turcite	0.05
Roller bearings	0.01 ÷ 0.02

- Torque due to the weight of the table  $M_W$  :

When the table does not move horizontally, but at an angle  $\delta$  like in figure **F. H5/1** the torque due to the weight of the table must also be considered.

$$M_W = \left[ \frac{m \cdot g \cdot \sin \delta \cdot h}{2\pi} \right] \cdot \frac{\%}{i}$$

- $M_W$  Torque due to the weight of the table in N·m.
- $\delta$  Inclination angle of the ballscrew with respect to the horizontal axis.
- $\%$  Table weight compensation factor that can vary between 0 and 1.

If the total table weight is compensated for by means of some sort of hydraulic system or counterweights so the motor makes the same effort to move the table up as to move it down, the % factor will be 0. At the other end, if no compensation is applied, % will be 1.

- Torque due to the needed cutting force  $M_C$ :

There is a cutting force between the tool and the part and this means a hindrance for moving the table. The torque necessary at the motor to make this movement is calculated as follows:

$$M_C = \left[ \frac{F \cdot g \cdot h}{2\pi} \right] \cdot \frac{1}{i}$$

- $M_C$  Torque due to the cutting force of the tool in N·m.
- $F$  Cutting force of the tool in kg-force.
- $g$  Gravitational acceleration, 9.81 in m/s<sup>2</sup>.



DDS  
HARDWARE

Ref.1310

**Motor speed calculation (rev/min)**

The machine will need a maximum speed (rev/min motor) in a linear movement of the table. Therefore, the motor must have a maximum speed of:

$$\text{RPM}_{\text{motor}} = \left[ \frac{V_{\text{max}}}{h} \right] \cdot i$$

$V_{\text{max}}$  is the maximum linear speed the table needs.

Select in the characteristics table of FAGOR synchronous motors see “AC synchronous servo motors” manual. FXM/FKM families a motor having:

- A stall torque equal to or greater than the calculated continuous torque  $M_s$ .
- A maximum turning speed equal to or greater than the calculated value RPM motor.

**5.****SELECTING CRITERIA**

Selection of the synchronous motor and its associated drive

**FAGOR** 

**DDS  
HARDWARE**

**Ref.1310**

# 5.

**SELECTING CRITERIA**

Selection of the synchronous motor and its associated drive

## Second motor pre-selection

### Calculation of inertia (J)

The next step is to calculate the load that the motor has to move when accelerating; that is the moment of inertia of all the elements it moves.

Total inertia (from now on **inertia**)  $J_{TOTAL}$  is due to the load  $J_{LOAD}$  and to the rotor of the motor itself  $J_{MOTOR}$ .

$$J_{TOTAL} = J_{LOAD} + J_{MOTOR}$$

The inertia due to load may be divided into that of the table + that of the ballscrew + that of the system used to compensate for non - horizontal axes + that of the pulley or gear used for transmission and which turns with the ballscrew (pulley 1). All these elements are affected by the reduction factor  $i$  as shown by the following equation.

The inertia due to the pulley that turns with the motor (pulley 2) is not affected by the  $i$  factor.

$$J_{LOAD} = \frac{J_{TABLE} + J_{BALLSCREW} + J_{PULLEY1} + J_{COMPENSATION}}{i^2} + J_{PULLEY2}$$

The inertia of each element is:

$$J_{TABLE} = m \cdot \left[ \frac{h}{2\pi} \right]^2$$

$$J_{BALLSCREW} = \frac{d^4 \cdot L \cdot \pi \cdot \alpha}{32}$$

$$J_{PULLEY1} = \frac{D_{p1}^4 \cdot L_1 \cdot \pi \cdot \alpha}{32}$$

$$J_{PULLEY2} = \frac{D_{p2}^4 \cdot L_2 \cdot \pi \cdot \alpha}{32}$$

The resulting inertia will be in kg·m<sup>2</sup>.

- L** Leadscrew length in m.
- L<sub>1</sub>** Width of pulley 1 in m.
- L<sub>2</sub>** Width of pulley 2 in m.
- D<sub>p1</sub>** Diameter of pulley 1 in m.
- D<sub>p2</sub>** Diameter of pulley 2 in m.
- α** Material density:  
7700 kg/m<sup>3</sup> for iron/steel  
2700 kg/m<sup>3</sup> for aluminum
- i, h** are data used earlier.

See previous sections.

The inertia of the motor  $J_{MOTOR}$  is:

$$J_{MOTOR} = J_{ROTOR} + J_{BRAKE}$$

this data may be obtained from the characteristics table of the corresponding motor manual.

Verify that in the characteristics table the rotor of the motor chosen in the 1st selection has an inertia  $J_{MOTOR}$  that meets the following condition:

$$J_{MOTOR} \geq [ J_{LOAD} / K ]$$

where **k** is a factor whose value depends on the application given to the motor.

The ideal will be to obtain a  $J_{MOTOR} = J_{LOAD}$

For a positioning axis, the typical value of "K" will be between 1 and 3.

**WARNING.** Note that if this requisite is not met, a new motor must be selected which meets the conditions of the 1st selection and the 2nd one.



DDS  
HARDWARE

Ref.1310

### Third motor pre-selection

#### Calculation of the acceleration torque and time

The required acceleration torque is determined by the total inertia to be moved and the needed acceleration.

The required acceleration is determined by the acceleration time  $t_{AC}$  which is the time estimated for the motor to reach its rated speed from zero rpm.

$$M_{ACCELERACION} = J_{TOTAL} \cdot \frac{2\pi \cdot n_N}{60 \cdot t_{AC}}$$

$n_N$  Rated motor speed .

$t_{AC}$  The time it takes the motor to go from 0 rpm to the rated speed.

Taking the value of  $t_{AC}$  from the equation:

$$t_{AC} = J_{TOTAL} \cdot \frac{2\pi \cdot n_N}{60 \cdot M_{ACCELERACION}}$$

#### Calculation of the needed rms torque $M_{RMS}$

The third and last motor selection requires a new data, the RMS torque.

$$M_{RMS} = \sqrt{(M_F + M_W + M_{AC})^2 \cdot \frac{t_{AC}}{T} + (M_F + M_W)^2 \cdot \frac{t_P}{T} + (M_F + M_W + M_C)^2 \cdot \frac{t_C}{T}}$$

where:

$t_{AC}$  acceleration time.

$t_P$  tool positioning time.

$t_C$  Cutting time in a machine cycle.

The typical values for  $t_{AC}$ ,  $t_P$  and  $t_C$  in machine tool cycle are:

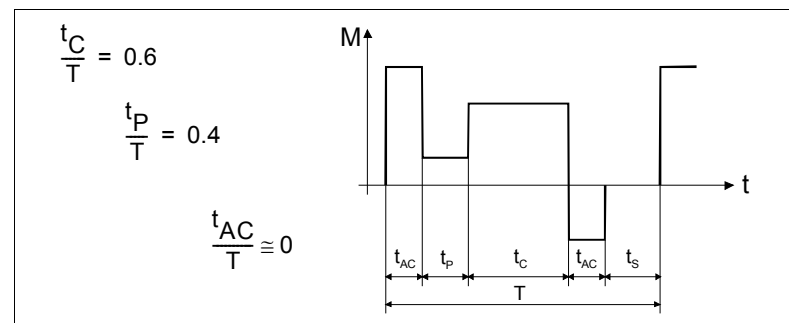

#### Calculation of the motor peak torque $M_{PEAK}$

The required maximum torque is the sum of the friction, weight and acceleration torque.

$$M_{MAX} = M_F + M_W + M_{AC}$$

For a given acceleration time, we will need specific acceleration torque and maximum torque. The motor must be able to provide a peak torque equal to or greater than the calculated maximum torque.

Verify that the motor chosen in previous selections meets the following condition:

Peak torque equal to or greater than the calculated max. torque:

$$M_{PEAK} \geq M_{MAX}$$

Rated torque equal to or greater than the calculated RMS value:

$$M_{RATED} \geq M_{RMS}$$

# 5.

## SELECTING CRITERIA

Selection of the synchronous motor and its associated drive



DDS  
HARDWARE

Ref.1310

# 5.

## SELECTING CRITERIA

Selection of the synchronous motor and its associated drive

### Summary of the three pre-selections

- Maximum speed equal to or greater than calculated value in  $RPM_{\text{motor}}$
- Stall torque equal to or greater than calculate continuous value  $M_{\text{continuous}}$
- Motor inertia equal to or greater than inertia  $J_{\text{LOAD}} / k$
- Peak torque equal to or greater than calculated value  $M_{\text{max}}$
- Rated torque equal to or greater than calculated RMS value  $M_{\text{rms}}$

### Drive selection

Once the motor has been selected, check the electrical characteristics table in the FXM/FKM AC servomotors manual.

There are several drives available for each motor and the peak torque obtained with each one of them will be different.

A drive has to be chosen whose peak current is greater than the one calculated for the application.



DDS  
HARDWARE

Ref.1310

## 5.2 Asynchronous spindle motor and servo drive selection

On the spindles of machine tools, it is important to maintain a constant turning speed of the spindle. To control this speed, the drive applies torque to the load according to the characteristics of this load as well as to the adjusted accelerations and decelerations.

Procedure to calculate the needed motor power:

1. Depending on the characteristics of the load, determine the rated values of the needed power (in continuous cycle, instantly and periodically).
2. Increase the value of that needed power, considering the efficiency of the power transmission and load dispersion.
3. Select the drive that offers the current needed to govern the motor in all duty cycles for that machine.

### Power demanded from a motor for a particular load

To determine the needed motor power, use the following formula:

$$P_{MOTOR} > P_{LOAD} + P_{ACCEL/DECEL}$$

The power of the motor must be greater than the sum of the power required by the load and the power required by the machine's accelerations and decelerations.

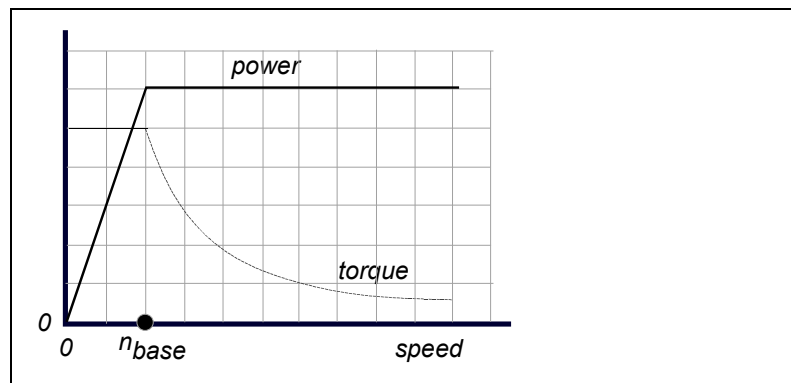

#### F. H5/2

Constant power required from the motor for a load regardless of the load.

#### T. H5/1 Constant motor power demanded by a load.

Constant motor power	
<b>Load type</b>	Constant power, regardless of speed
<b>Examples</b>	Winding machines at constant tension Milling spindle Lathe spindle
<b>Torque/speed characteristics</b>	The torque decreases from base speed on
<b>Motor Power</b>	The rated power of the drive will be the one demanded by the load.

### Power required by the load

The power demanded from an asynchronous spindle motor in a turning or machining center is determined by the cutting power.

A good cutting process requires the asynchronous spindle motor to be working at constant power and with a power range between 1:3 and 1:5.

The power values used for a cutting operation on a lathe, mill or machining center with a drill are calculated using the following formulas.

For a more accurate calculation of the power required, one must bear in mind different factors such as cutting oil, material, shape of the tools, hardness of the material machined, etc.

# 5.

## SELECTING CRITERIA

Asynchronous spindle motor and servo drive selection



DDS  
HARDWARE

Ref.1310

# 5.

## SELECTING CRITERIA

Asynchronous spindle motor and servo drive selection

For lathe work, a cutting blade forces against the part to be machined, while this is turning. See figure **F. H5/3**.

The power required, **P<sub>c</sub>** is calculated as follows:

$$V = \frac{\pi \cdot d \cdot N_s}{1000} \quad (\text{m/min})$$

$$P_c = \frac{K_s \cdot d \cdot L \cdot v}{60 \cdot 1000 \cdot \eta_c} = \frac{d \cdot L \cdot v}{S_c \cdot \eta_c} \quad (\text{kW})$$

### F. H5/3

Machining for lathe. Cutting power.

- V** Cutting speed in m/min
- K<sub>s</sub>** Relative cutting resistance in N/mm<sup>2</sup>
- d** Cutting depth in mm
- L** Length of the blade, or feedrate per full turn in mm
- D** Diameter of the part machined in mm
- N<sub>s</sub>** Spindle turning speed in rpm
- η<sub>c</sub>** Mechanical efficiency (varies from 0.7 to 0.85)
- S<sub>c</sub>** Cutting efficiency. Cutting volume per kilowatt every minute in (cm<sup>3</sup>/kW)/min

In the case of a milling machine, the cutter is mounted on the spindle itself and turns with this to cut the material. See figure **F. H5/4**.

The power required, **P<sub>f</sub>** is calculated as follows:

$$P_f = \frac{K_s \cdot d \cdot W \cdot f}{60 \cdot 1000^2 \cdot \eta_f} = \frac{d \cdot W \cdot f}{1000^2 \cdot S_f \cdot \eta_f} \quad (\text{kW})$$

### F. H5/4

Machining for mill. Cutting power.

- K<sub>s</sub>** Relative cutting resistance in N/mm<sup>2</sup>
- d** Cutting depth in mm
- W** Cutting width in mm
- f** Feedrate in mm/min
- N<sub>s</sub>** Spindle turning speed in rpm
- η<sub>f</sub>** Mechanical efficiency (varies from 0.7 to 0.8)
- S<sub>f</sub>** Cutting efficiency. Cutting volume per kilowatt every minute in (cm<sup>3</sup>/kW)/min



DDS  
HARDWARE

Ref.1310

In the case of a drill, the bit is mounted on the spindle itself and turns with this to drill the material. See figure **F. H5/5**.

The power required in this case **P<sub>d</sub>** may be calculated with the following formula:

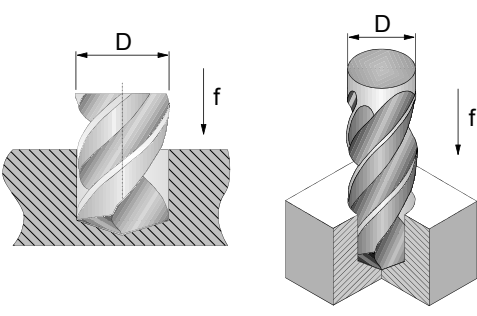

$$P_d = \frac{M \cdot 2\pi \cdot n}{60 \cdot 100 \cdot 1000 \cdot \eta_d} = \frac{\pi \cdot D^2 \cdot f}{4 \cdot 1000 \cdot S_d \cdot \eta_d} \text{ (kW)}$$

**F. H5/5**

Drilling. Required power.

- M** Drilling load torque in N·cm
- n** Spindle turning speed in rpm
- D** Hole diameter in mm
- f** Feedrate in mm/min
- η<sub>d</sub>** Mechanical efficiency (varies from 0.7 to 0.85)
- S<sub>d</sub>** Cutting efficiency. Cutting volume per kilowatt every minute (cm<sup>3</sup>/kW)/min

In the event of governing a **gravitational load**, the power required depends very much on the presence or absence of balance weights (crane or elevator). See figure **F. H5/6**.

The power required in this case, **P<sub>GL</sub>** and **P<sub>GLC</sub>** may be calculated as follows:

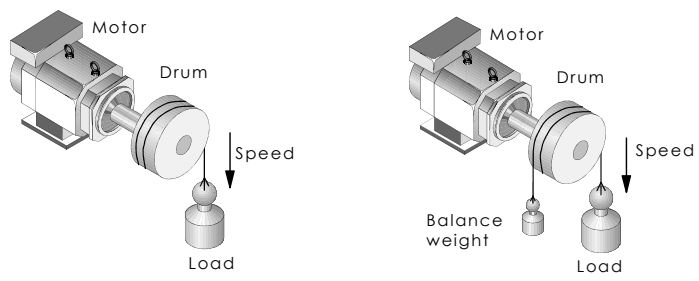

$$P_{GL} = \frac{m_L \cdot V}{6120 \cdot \eta} \text{ (kW)}$$

$$P_{GLC} = \frac{(m_L - m_c) \cdot V}{6120 \cdot \eta} \text{ (kW)}$$

**F. H5/6**

Gravitational load. Required power.

- V** Linear speed in m / min
- η** Mechanical efficiency
- m<sub>L</sub>** Table mass in kg
- m<sub>c</sub>** Counterweight mass in kg

Governing a **frictional load**, this is the case of horizontal movements such as a conveyor belt or a movable table, the required power depends on the friction coefficient **μ**. See figure **F. H5/7**.

**5.**

**SELECTING CRITERIA**

Asynchronous spindle motor and servo drive selection



**DDS  
HARDWARE**

**Ref.1310**



**T. H5/3** Different accelerations depending on speed.

<b>Method</b>	Different accelerations depending on speed
<b>Control</b>	Linear acceleration avoiding abrupt variations in transmitted torque.
<b>Comment</b>	Emulation of the square sine function for speed by using ramps.

□ Limited acceleration and choke. Choke =  $(\Delta \text{acceleration} / \Delta t)$ .

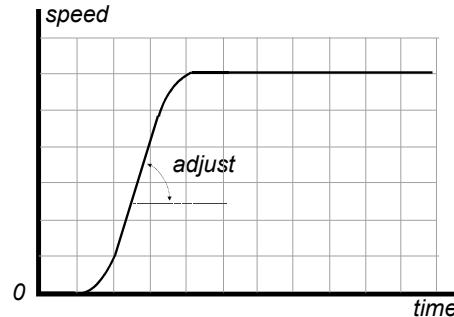

**F. H5/10**

Acceleration and choke limit.

**T. H5/4** Acceleration and choke limit.

<b>Method</b>	Acceleration and choke limit.
<b>Control</b>	Progressive linear acceleration, avoiding abrupt variations of transmitted torque.
<b>Comment</b>	Approach square sine function (bell shape) for the speed.

The capability demanded from the motor is determined by the following formulas:

Capacity required by the motor in the constant torque area:  $(0 < N_M < N_B)$

$$P_N = \left( \frac{2\pi}{60} \right)^2 \cdot \frac{J_M \cdot N_M^2}{1000 \cdot t} \text{ (kW)}$$

Capacity required by the motor in the constant torque and constant power area:  $(0 < N_M < N_{max})$

$$P_N = \left( \frac{2\pi}{60} \right)^2 \cdot \frac{J_M \cdot (N_M^2 + N_B^2)}{2000 \cdot t} \text{ (kW)}$$

- J<sub>M</sub>** Inertia of the load in kg·m<sup>2</sup> as viewed from the motor shaft
- P<sub>N</sub>** Rated power at base speed kW
- N<sub>max</sub>** Maximum motor speed in rev/min.
- N<sub>B</sub>** Motor base speed in rev/min.
- N<sub>M</sub>** Motor speed reached after a time period t in rpm
- t** Acceleration time until N<sub>M</sub> (in seconds) is reached

We will now give several examples of calculations using a mechanical specifications and for a standard motor. The results could vary from real ones through mechanical losses, fluctuations in mains voltage, or inaccuracies of mechanical data.

**Example.**

**Data:**

Acceleration time:

Between 0 and 1500 rpm in 0.5 s. (1)

Between 0 and 6000 rpm in 2.5 s. (2)

Motor inertia: **J<sub>motor</sub>** = 0.13 kg·m<sup>2</sup>

Motor base speed: **N<sub>b</sub>** = 1500 rev/min

**5.**

SELECTING CRITERIA  
Asynchronous spindle motor and servo drive selection



**DDS  
HARDWARE**

**Ref.1310**

# 5.

SELECTING CRITERIA  
Asynchronous spindle motor and servo drive selection

**Calculations:**

1. With speed between 0 and 1500 rpm.

$$P_N = \left[ \frac{2\pi}{60} \right]^2 \cdot \frac{J_M \cdot N_M^2}{1000t} \text{ [kW]} = \left[ \frac{2\pi}{60} \right]^2 \cdot \frac{0.13 \cdot 1500^2}{1000 \cdot 0.5} = 6.41 \text{ [kW]} \quad [1]$$

2. With speed between 0 and 6000 rpm.

$$P_N = \left[ \frac{2\pi}{60} \right]^2 \cdot \frac{J_M [N_M^2 + N_B^2]}{2000t} \text{ [kW]} = \left[ \frac{2\pi}{60} \right]^2 \cdot \frac{0.13 [6000^2 + 1500^2]}{2000 \cdot 2.5} = 10.89 \text{ [kW]} \quad [2]$$

**Calculation of acceleration and braking time**

After selecting the mechanical characteristics and the power of the drive, the acceleration and braking time is calculated as follows:

Constant torque area:  
( $0 < N_M < N_B$ )

$$t_1 = \frac{2\pi \cdot J_M \cdot N_M}{60 \cdot T_M} \text{ (s)}$$

Constant power area:  
( $N_B < N_M < N_{max}$ )

$$t_2 = \frac{2\pi \cdot J_M \cdot (N_M^2 - N_B^2)}{120 \cdot T_M \cdot N_B} \text{ (s)}$$

Constant torque & power area:  
( $N_B < N_M < N_{max}$ )

$$t_3 = (t_1 + t_2) = \frac{2\pi \cdot J_M \cdot (N_M^2 + N_B^2)}{120 \cdot T_M \cdot N_B} \text{ (s)}$$

- J<sub>M</sub>** Inertia of the load in kg·m<sup>2</sup> as viewed from the motor shaft
- T<sub>M</sub>** Rated torque at base speed in N·m
- N<sub>max</sub>** Maximum motor speed in rpm.
- N<sub>B</sub>** Motor base speed in rpm.
- N<sub>M</sub>** Motor speed reached after a time period t in rev/min

**Calculation of power with intermittent load**

Forming the drive to the right dimensions has to be done with the greatest care when the application involves a periodical starting and stopping operation, frequently repeated as in the case of threading with a miller.

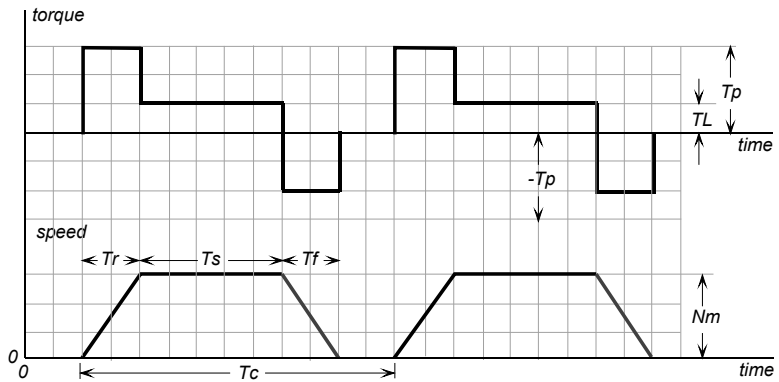

$$T_R = \sqrt{\frac{T_P^2 \cdot (t_r + t_f) + T_L^2 \cdot t_s}{t_c}} \text{ (Nm)}$$

**F. H5/11**

Periodic start-stop operation

For a cycle like the one shown in the figure **F. H5/11** which includes acceleration and stopping, the equivalent effective torque **T<sub>R</sub>** of equation must be within the S1 dimension given for the drive torque.



DDS  
HARDWARE

Ref.1310

### 5.3 Drive selection

When selecting an FM7 or FM9 motor, see the manual of the AC spindle motor that indicates the drive associated with the selected motor.

**5.****SELECTING CRITERIA**  
Drive selection**FAGOR** **DDS  
HARDWARE****Ref.1310**

## 5.4 Power supply selection

### Calculation of the power required from the power supply by the synchronous servo motors

Initially, considering the mechanical power provided by the motors:

#### T. H5/5 Power supply selection depending on the mechanical power output of the motor.

##### SYNCHRONOUS FXM & FKM

Power (characteristics table)

n : Max. axis speed in the application (rpm)  
 nN: Motor rated speed (rpm)  
**Pa= Pcal·1.17· [n/nN]** : Axis power (kW)

Axes	Pcal	n	nN	Pa
	kW	rpm	rpm	kW

**GROUP I**  
 0 to 2 kW  
 Synchronous

1				
2				
3				

Sum of GROUP I:  \*  Ki →

**GROUP II**  
 0 to 8.5 kW  
 Synchronous

1				
2				
3				

Sum of GROUP II:  \*  Kii →  +

**GROUP III**  
 8.5 to 27 kW  
 Synchronous

1				
2				
3				

Sum of GROUP III:  \*  Kiii →  +

=

**SUM OF POWER: (kW)**  **1**

Synchronous  
 motors per group

K factor

1
2
3
4
5
6

1
0.63
0.50
0.38
0.33
0.28

... where:

**Pcal**: motor power (kW) according to the motor characteristics table.

**1.17**: coefficient that stores the efficiency of the motor (0.9) and that of the drive (0.95).

The servo set is divided in groups depending on their power by applying to each one a simultaneity factor Ki, Kii, Kiii.

5.

SELECTING CRITERIA  
 Power supply selection



DDS  
 HARDWARE

Ref.1310

Then, depending on the power for S3-5% cycles that could be requested by the drives at any time:

**T. H5/6** Selection of the power supply depending on the power for S3-5% cycles supplied by the drive for IGBT switching frequencies of 4 kHz and 8 kHz.

**SYNCHRONOUS FXM & FKM**

Power P (S3-5% cycle)

		P (S3-5%)					
		kW					
<b>GROUP I</b> 0 to 2 kW Synchronous	1		<b>Sum of GROUP I:</b>	*	Ki		
	2					→	
	3						
		+					
<b>GROUP II</b> 0 to 8.5 kW Synchronous	1		<b>Sum of GROUP II:</b>	*	Kii		
	2					→	
	3						
		+					
<b>GROUP III</b> 8.5 to 27 kW Synchronous	1		<b>Sum of GROUP III:</b>	*	Kiii		
	2					→	
	3						
		=					

**SUM OF POWER: (kW) 3**

Synchronous motors per group	K factor	Drive	P (S3-5%)
1	1	AXD 1.08	6
2	0.63	AXD 1.15	12
3	0.50	AXD 1.25	19
4	0.38	AXD 1.35	27
5	0.33	AXD 2.50	36
6	0.28	AXD 2.75	48
		AXD 3.100	77
		AXD 3.150	95

in kW

# 5.

SELECTING CRITERIA

Power supply selection



**DDS  
HARDWARE**

**Ref.1310**

**Calculation of the power required from the power supply by the asynchronous motors**

**FAGOR asynchronous spindle motor FM7**

**T. H5/7** Power supply selection when using an FM7 asynchronous spindle motor with E01 and E02 releases.

**ASYNCHRONOUS FOR SPINDLE, FM7. Releases E01 & E02**

Max. power consumed by the power supply (kW)

ASYNCHRONOUS

Asynchronous for spindle	P <sub>m</sub>
1	
2	

**SUM OF POWER: (kW) 2**

**P<sub>m</sub>**: Required power obtained for the asynchronous spindle drive in S6-40 % cycles. This data includes the internal losses of the drive.

Asynchronous spindle motor	Power (kW)		η (%)		Drive power (kW)	Drive for asynchronous spindle motor	Drive η (%)	P <sub>m</sub> (kW)
	S1	S6-40	S1	S6-40				
<b>FM7-A037</b>	3.7	5.5	83.5	83.5	6.6	SPD 1.25	90	7.4
<b>FM7-A055</b>	5.5	7.7	86.0	84.5	9.1	SPD 1.25	90	10.1
<b>FM7-A075</b>	7.5	11.0	86.5	84.6	13.0	SPD 1.35	90	14.4
<b>FM7-A090</b>	9.0	13.0	87.3	85.7	15.2	SPD 2.50	90	16.9
<b>FM7-A110</b>	11.0	15.5	90.2	89.2	17.4	SPD 2.50	90	19.3
<b>FM7-A150</b>	15.0	22.0	90.4	89.3	24.6	SPD 2.75	90	27.4
<b>FM7-B120</b>	12.0	18.5	91.0	90.4	20.5	SPD 2.75	90	22.7
<b>FM7-A185</b>	18.5	26.0	91.8	91.5	28.4	SPD 2.85	90	31.6
<b>FM7-A220</b>	22.0	33.0	89.2	88.1	37.5	SPD 3.100	90	41.6
<b>FM7-B170</b>	17.0	25.0	89.1	87.7	28.5	SPD 2.85	90	31.7
<b>FM7-A300</b>	30.0	45.0	92.1	91.6	49.1	SPD 3.150	90	54.6
<b>FM7-A370</b>	37.0	56.0	92.5	91.7	61.1	SPD 3.200	90	67.9
<b>FM7-B220</b>	22.0	33.0	91.3	90.5	36.5	SPD 3.100	90	40.5
<b>FM7-B280</b>	28.0	42.0	91.1	90.0	46.7	SPD 3.150	90	51.9
<b>FM7-A510</b>	51.0	71.0	92.8	92.2	77.0	SPD 3.200	90	85.6
<b>FM7-C215</b>	21.5	29.0	85.4	82.7	35.1	SPD 3.150	90	39.0
<b>FM7-C270</b>	27.0	37.0	86.6	83.9	44.1	SPD 3.200	90	49.0
<b>FM7-E600</b>	60.0	80.0	92.2	91.4	87.6	SPD 3.200	90	97.3

where:

**P<sub>m</sub>** Maximum power that the drive may demand from the power supply in each motor-drive combination. It includes the power dissipated by the drive itself (in kW).

**5.**

**SELECTING CRITERIA**  
Power supply selection



**DDS  
HARDWARE**

**Ref.1310**

**T. H5/8** Power supply selection when using an FM7 asynchronous spindle motor with E03 release.

**ASYNCHRONOUS FOR SPINDLE, FM7. Release E03)**

Max. power consumed by the power supply (kW)

ASYNCHRONOUS	Asynchronous for spindle	<b>P<sub>m</sub></b>
	1	
	2	

**SUM OF POWER: (kW)      2**

**P<sub>m</sub>**: Required power obtained for the asynchronous spindle drive in S6-40% cycles. This data includes the internal losses of the drive.

**In star**

Asynchronous spindle motor	Power (kW)		η (%)		Drive power (kW)	Drive for asynchronous spindle motor	Drive η (%)	P <sub>m</sub> (kW)
	S1	S6-40	S1	S6-40				
<b>FM7- D055</b>	5.5	7.7	86.0	84.5	9.1	SPD 1.35	90	10.1
<b>FM7- D075</b>	7.5	11.0	86.5	84.6	13.0	SPD 2.50	90	14.4
<b>FM7- D110</b>	11.0	15.5	90.2	89.2	17.4	SPD 2.75	90	19.3
<b>FM7- D150</b>	15.0	22.0	90.4	89.3	24.6	SPD 2.85	90	27.4
<b>FM7- D185</b>	18.5	26.0	91.8	91.5	28.4	SPD 2.85	90	31.6
<b>FM7- D220</b>	22.0	33.0	89.2	88.1	37.5	SPD 3.100	90	41.6

**In triangle**

Asynchronous spindle motor	Power (kW)		η (%)		Drive power (kW)	Drive for asynchronous spindle motor	Drive η (%)	P <sub>m</sub> (kW)
	S1	S6-40	S1	S6-40				
<b>FM7- D055</b>	5.5	10.0	86.0	84.5	11.8	SPD 1.35	90	13.1
<b>FM7- D075</b>	7.5	13.0	86.5	84.6	15.4	SPD 2.50	90	17.1
<b>FM7- D110</b>	11.0	20.0	90.2	89.2	22.4	SPD 2.75	90	24.9
<b>FM7- D150</b>	15.0	26.0	90.4	89.3	29.1	SPD 2.85	90	32.4
<b>FM7- D185</b>	18.5	32.0	91.8	91.5	35.0	SPD 2.85	90	38.9
<b>FM7- D220</b>	22.0	40.0	89.2	88.1	45.4	SPD 3.100	90	50.4

where:

**P<sub>m</sub>** Max. power that the drive may demand from the power supply in each motor-drive combination. It includes the power dissipated by the drive itself (in kW).

**5.**  
**SELECTING CRITERIA**  
Power supply selection



**DDS  
HARDWARE**

**Ref.1310**

**5.**  
**SELECTING CRITERIA**  
Power supply selection

**T. H5/9** Power supply selection when using an FM7 asynchronous spindle motor with HS3 release.

**ASYNCHRONOUS FOR SPINDLE, FM7. Release HS3**

Max. power consumed by the power supply (kW)

ASYNCHRONOUS	Asynchronous for spindle	<b>P<sub>m</sub></b>
	1	
	2	
<b>SUM OF POWER: (kW)</b>		<b>2</b>

**P<sub>m</sub>**: Required power obtained for the asynchronous spindle drive in S6-40% cycles. This data includes the internal losses of the drive.

**In star**

Asynchronous spindle motor	Power (kW)		η (%)		Drive power	Drive for asynchronous spindle motor	Drive	<b>P<sub>m</sub></b>
	S1	S6-40	S1	S6-40	(kW)		η (%)	
<b>FM7- D075</b>	7.5	11.0	86.5	84.6	12.7	SPD 2.50	90	14.1
<b>FM7- D110</b>	11.0	15.5	90.2	89.2	17.4	SPD 2.75	90	19.3
<b>FM7- D185</b>	18.5	26.0	91.8	91.5	28.4	SPD 2.85	90	31.6
<b>FM7- D220</b>	22.0	33.0	89.2	88.1	37.5	SPD 3.100	90	41.6

**In triangle**

Asynchronous spindle motor	Power (kW)		η (%)		Drive power	Drive for asynchronous spindle	Drive	<b>P<sub>m</sub></b>
	S1	S6-40	S1	S6-40	(kW)		η (%)	
<b>FM7- D075</b>	7.5	13.0	86.5	84.6	15.4	SPD 2.50	90	17.1
<b>FM7- D110</b>	11.0	20.0	90.2	89.2	22.4	SPD 2.75	90	24.9
<b>FM7- D185</b>	18.5	32.0	91.8	91.5	35.0	SPD 2.85	90	38.9
<b>FM7- D220</b>	22.0	40.0	89.2	88.1	45.4	SPD 3.100	90	50.4

where:

**P<sub>m</sub>** Max. power that the drive may demand from the power supply in each motor-drive combination. It includes the power dissipated by the drive itself (in kW).



DDS  
HARDWARE

Ref.1310

**Non-FAGOR asynchronous spindle motor**

For non-FAGOR asynchronous spindle motors (e.g.: a high speed spindle) the previous tables for standard FAGOR motors are not available.

To properly calculate the power demanded by the non-FAGOR asynchronous spindle from the power supply, it is necessary:

- To know the maximum power to be provided at the axis. Always use the mechanical power for cycles S1 or S6-40% (depending on the duty cycle of the applicaton).

<b>NOTE.</b> Never use the peak power!
--

- Obtain the power at the motor terminals by dividing the previous value by the efficiency of the motor.

If the value of the motor efficiency (eff) is unknown, apply the following rule. For:

**P < 22 kW**      motor eff = 85% ( $\eta = 0.85$ )

**P > 22 kW**      motor eff = 90% ( $\eta = 0.90$ )

- Divide the result by the efficiency of the drive.

drive eff = 90% ( $\eta = 0.90$ )

**5.**

**SELECTING CRITERIA**  
Power supply selection

**FAGOR** 

**DDS  
HARDWARE**

**Ref.1310**





**3. The range of FAGOR power supplies that may be selected is:**

**T. H5/12** Power supplies of the FAGOR catalog. They indicate: Rated power, admitted mains voltage and whether it outputs 24 V DC or not.

**RANGE OF FAGOR POWER SUPPLIES**

NON REGENERATIVE	Model	Output power S1	Input voltage	Integrated 24V power supply
	PS-25B4	25 kW	400-460 V AC	Yes
	PS-65A	65 kW	400-460 V AC	No

REGENERATIVE	Model	Output power S1	Input voltage	Integrated 24V power supply
	XPS-25	25 kW	400-460 V AC	Yes
	XPS-65	65 kW	400-460 V AC	Yes

Model	S1/S6-40% output power	Input voltage	Integrated 24V power supply
RPS-20	20/26 kW	400-460 V AC	Yes
RPS-45	45/59 kW	400-460 V AC	Yes
RPS-75	75/97 kW	400-460 V AC	Yes
RPS-80	80/104 kW	400-460 V AC	Yes

**4. Use the following sheet to calculate the input transformer, and the section of the mains cable.**

**T. H5/13** Power of the input transformer.

**MAINS VOLTAGE**

The FAGOR DDS servo drive system requires a mains voltage between 400 and 460 V AC

**TRANSFORMER**

A power transformer or auto-transformer must be used

$$[ 1 + 2 ] * 1.05 \text{ kVA} = 4 \text{ kVA}$$

**NOTE.** When using an isolating transformer, the secondary must have a star connection and its mid point must be accessible so it can be connected to ground. This means that the output voltage of the transformer/autotransformer is maintained for the indicated apparent power. **Note that** if the system has an **XPS power supply**, the rated power Pm of cell (2) of the previous expression corresponds to the sum of the Pn's of all the asynchronous spindle motors of the system, whose value is the result of applying the expression **Pn = 1.4·Pmax** for each of them and then adding them all. **Pmax will be the motor's maximum braking power and it may be, in general, close to the power of the asynchronous spindle motor in S6.** If it is a **PS power supply**, cell (2) will register the value obtained from the table **F. H5/7**, table **F. H5/8** or table **F. H5/9** accordingly.

**5.**

**SELECTING CRITERIA**  
Power supply selection



DDS  
HARDWARE

Ref.1310

**T. H5/14** Selection of the mains connection cable.

**POWER CABLE FOR MAINS CONNECTION**

Vmains from 400 to 460 V AC      Rated current through the mains cable

---

**MAINS POWER** ↓

**4** (kW) \* 1000 / (√3 · Vmains) =  A → **C**

---

**COMPACT AXIS DRIVES (ACD):**

**RATED CURRENT ON FXM & FKM MOTORS** =  A → **C**

---

**COMPACT SPINDLE DRIVES (SCD):**

**MAX. CURRENT ON FM7/FM9 MOTORS** =  A → **C**

	Power cable
In Amperes	Reference
if C < 12.5	MPC-4x1.5
if C < 16.5	MPC-4x2.5
if C < 23	MPC-4x4
if C < 29	MPC-4x6
if C < 40	MPC-4x10

The purchase order must indicate the length of the cables

**5.**

**SELECTING CRITERIA**  
Power supply selection



DDS  
HARDWARE

Ref.1310

## 5.5 Capacitor module selection guide

The CM 1.60 is a capacitor module that increases the electrical capacitance of the power bus in 4230 μF. It should be installed on machines with very short duty cycles (very repetitive accelerations and decelerations) and with low braking energy (e.g. a punch press).

The following table indicates how much extra energy W is stored in (Ws) when the bus voltage increases from the rated value VBus to the Ballast circuit activating voltage (also called Crowbar activation voltage, VCrowbar).

Considering the different combinations of power supplies modules + CM 1.60 and different mains voltage.

$$W = \frac{C}{2} [ V_{CROWBAR}^2 - V_{BUS}^2 ] \text{ (Ws)}$$

with units:

C in Farads

VCrowbar in volts

VBus = √2·Vmains in volts

W in Ws → joules)

**T. H5/15** Extra energy that may be stored (in Ws).

Modules	Capac. (μF)	Crowbar activation voltage (V)	Crowbar deactivation voltage (V)	W (Ws) for Vmains 400 V	W (Ws) for Vmains 460 V
PS-25B4	820	770	760	111.9	69.6
PS-65A	940	770	760	128.3	79.8
XPS-25	1175	770	760	160.3	99.7
XPS-65	2520	770	760	343.8	213.8
CM 1.60+PS-25B4	5050	770	760	689.1	428.5
CM 1.60+PS-65A	5170	770	760	705.4	438.7
CM 1.60+XPS-25	5405	770	760	737.5	458.6
CM 1.60+XPS-65	6750	770	760	921.0	572.7

5.

SELECTING CRITERIA  
Capacitor module selection guide



DDS  
HARDWARE

Ref.1310

## 5.6 Ballast resistor selection guide

Calculate the value of:

**W<sub>m</sub>** Energy generated by the braking of each system motor.

**P<sub>e</sub>** Rms power generated by all braking of all the motors throughout a complete duty cycle.

Based on the following formulae:

$$W_m = W_p + \frac{1}{2} \cdot J_t \left[ \frac{2\pi \cdot n}{60} \right]^2 \quad [Ws]$$

$$W_p = m \cdot g \cdot \Delta h$$

$$P_e = \sqrt{\frac{\sum_i \frac{W_{mi}^2}{t_i}}{T}} \quad [w]$$

where:

- J<sub>t</sub>** Total inertia of the servo system (motor + mechanics) in kg.m<sup>2</sup>.
- n** Turning speed of the motor when the braking starts in rpm.
- W<sub>mi</sub>** Energy of each braking during a cycle of time T in Ws.
- W<sub>p</sub>** Potential energy lost by the machine mass while braking (only on non-compensated axes) in Ws.
- t<sub>i</sub>** Braking time (in seconds) when the W<sub>mi</sub> energy is generated.
- T** Time (in seconds) in a full cycle.
- Dh** Height (in m) lost while braking.
- W<sub>mx</sub>** Maximum energy among all the W<sub>m</sub>.
- P<sub>mx</sub>** Maximum power generated by all the braking, given by the maximum value among all the (W<sub>mi</sub> / t<sub>i</sub>) quotients of each braking in kW.

$$P_{mx} = \left( \frac{W_{mi}}{t_i} \right)_{\max} \quad [kW]$$

# 5.

SELECTING CRITERIA  
Ballast resistor selection guide



DDS  
HARDWARE

Ref.1310

Once the values of **P<sub>mx</sub>** and **P<sub>e</sub>** are calculated, follow these flow charts:

**NOTE.** If you have external resistor ER+TH-□/□ or ER-TH-18/□+FAN, already discontinued, use this diagram to obtain the Ohm values required for each power supply.

**5.**  
**SELECTING CRITERIA**  
 Ballast resistor selection guide

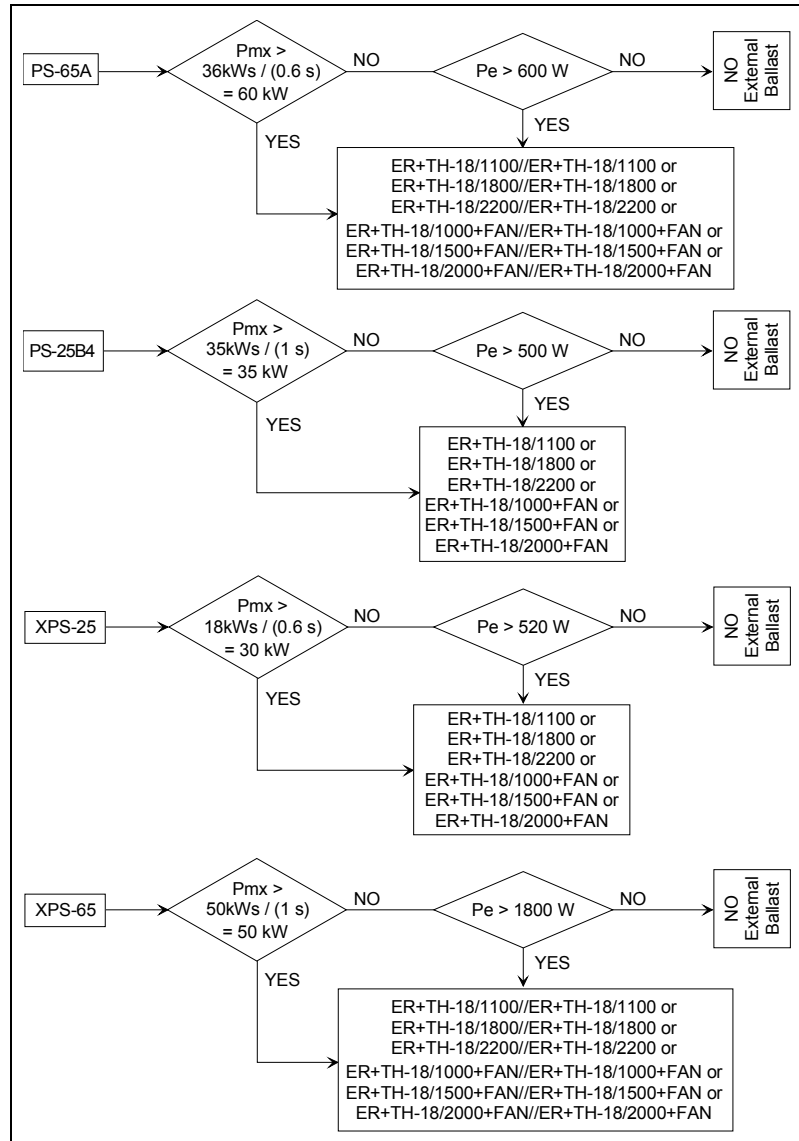

**F. H5/12**

Selection of the Ballast resistor for the power supplies.



DDS  
 HARDWARE

Ref.1310

- When using compact drive modules that integrate the power supply.



**MANDATORY.** On all compact drives (except those whose reference is SCD...-NR), the external resistor supplied with the units. ACD/SCD/CMC 1.08 /1.15 models are also an exception.

On compact drives “ACD/SCD/CMC 1.08 /1.15”, as opposed to the rest of the compact models, do not install any external Ballast resistor. The internal one is enough, except on “SCD 1.15” models where it would be possible to install the internal resistor ER+TH-43/350 if the application so required.

In general, on compact models “ACD/SCD/CMC 1.08/1.15” the internal dissipation Ballast resistor will be enough, but if it is not in a particular situation, it is possible to install an external resistor of the same Ohm value as the internal one and greater dissipation power.

**NOTE.** Actually, the external resistor provided with the unit is considered enough for most applications. If it is not enough, install one of the same Ohm value and greater power.

On any compact drive whose reference is SCD...-NR no external Ballast resistor will be supplied with the unit. The user will place the order for the external resistor required by the application with a FAGOR representative.

5.

**SELECTING CRITERIA**  
Ballast resistor selection guide

**FAGOR** 

**DDS  
HARDWARE**

**Ref.1310**



A large grid for selection criteria, consisting of 15 columns and 25 rows. A pencil icon is located in the top right corner of the grid.

**5.**

**SELECTING CRITERIA**



**DDS  
HARDWARE**

**Ref.1310**

# POWER LINE CONNECTION

# 6

## 6.1 Mains connection

The FAGOR DDS modular servo drive system is designed to be connected to TN type three-phase mains with values within the voltage range between 400-10% and 460+10% V AC and a mains frequency of 50/60 Hz.

Connecting it to a different voltage range requires the use of transformers or autotransformers.

The connection may vary depending on the type of mains and electromagnetic compatibility required by the machine.

Certain mandatory protection devices must be added to the mains lines. Others are optional.

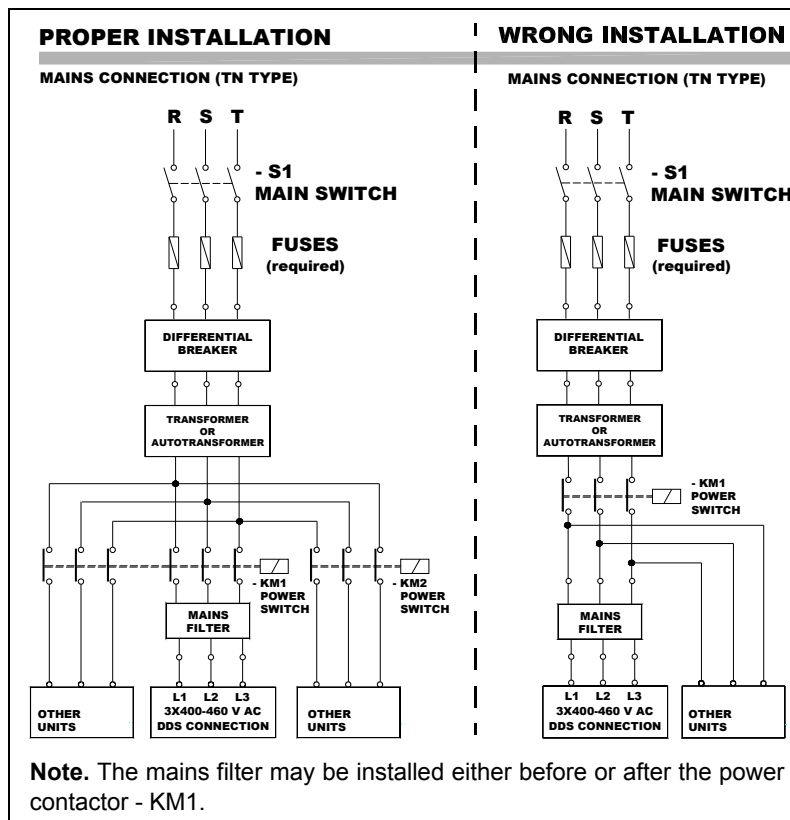

### F. H6/1

Diagram to connect the DDS system to mains.

#### MANDATORY.

Never connect in parallel with the DDS system other elements such as motors, inductive components, etc. to avoid the risk of poor system performance when stopping the machine.

Always connect the power supply of other equipment being installed and run together with the DDS system through a second contactor - **KM2** or through auxiliary contacts of the power (main) contactor - **KM1**.



# 6.

## POWER LINE CONNECTION Mains connection



The diagram of figure **F. H6/1** shows the different possibilities and how to connect it.

After the main switch - **S1**, place the protection fuses, the differential breaker, the 400/460 V AC transformer (only if necessary), the power contactor - **KM1** to turn on/off the DDS system and the MAINS FILTER □□A for electromagnetic disturbances.

**INFORMATION.** The MAINS FILTER □□A may be installed either before or after the power contactor - **KM1**.

## 6.2 Protection fuses

To protect the FAGOR DDS servo drive system, fuses must be included on the lines coming from mains. Figure F. H6/1 of this chapter shows its location.



**INFORMATION.** Note that FAGOR does not supply the fuses; in other words, the FAGOR DDS servo drive system does not include the fuses as accessories.

The lines going to the auxiliary power supply, integrated in all FAGOR power supplies (except the PS-65A that needs an external auxiliary power supply called APS-24) and even those of the compact drives do not need external protection fuses because they are already integrated in all of them. Therefore:



**MANDATORY.** Do not install external protection fuses in the power lines feeding the auxiliary power supply. These fuses are already integrated into all FAGOR power supplies.

### Technical data

Extremely fast fuses must be installed in the mains lines to protect the semiconductors sized according to the type of power supply.

Depending on the power supply being installed, they will be selected according to the characteristics indicated in table F. H6/1 which are the ones to be met by the fuses that must necessarily be installed in the line input of the DDS system to protect it properly.

**T. H6/1** Technical data of the fuses to be installed in a DDS system with power supply.

	PS-25B4	PS-65A	XPS-25	XPS-65
In	≥ 40 A	> 100 A	≥ 40 A	> 100 A
Isurge (1 s)	> 115 A	> 325 A	> 115 A	> 325 A
Clearing I <sup>2</sup> t (A <sup>2</sup> s)	< 500	< 15000	< 500	< 15000



**INFORMATION.** Actually, IGBT components cannot be protected with fuses. Therefore, when using RPS power supplies, the protection does not prevent the module from breaking down. Using them minimizes the number of components that may be damaged as a result of a possible malfunction.

When using compact drives, the fuses must be selected according to the following table:

**T. H6/2** Technical data of the fuses to be installed in a DDS system with compact drives.

	ACD/SCD/CMC				SCD
	1.08	1.15	1.25	2.35 2.50	2.75
In	> 5.6 A	> 10.6 A	> 17.7 A	> 28 A	> 41 A
Isurge (0.5 s)	> 8 A	> 15 A	> 25 A	> 35 A	> 53 A
Clearing I <sup>2</sup> t (A <sup>2</sup> s)	< 120	< 338	< 900	< 900	< 1350

### Recommended fuses

Table T. H6/3 and table T. H6/4 offer a variety of fuses from different manufacturers and may be used as a reference. These references of the fuses shown in these tables are valid for installations where the system is connected directly to mains and for the rated power of the units. For lower-than-rated power, we recommend to select the fuses according to the characteristics of each system.

# 6.

POWER LINE CONNECTION  
Protection fuses

**T. H6/3** Fuses to be installed in mains line depending on the power supply installed.

Manufacturer	PS-25B4 XPS-25 RPS-20	PS-65A XPS-65 RPS-45	RPS-75 RPS-80
<b>BUSMANN</b>	FWH45B	RF00-125A	-
	XL50F-45A	XL50F-125A	-
	RF-000-40A	RF-000-125A	-
	40FE	100FE	160FE
	170M2611	170M1318	170M1319
	170M3009	170M3013	170M3014
<b>GOULD</b>	A00-66C5D8	A00-66C125D8	-
	A00-66C5D1	A00-66C125D1	-
<b>FERRAZ</b>	6.9 gRB 00 D08L 040	6.9 gRB 00 D08L 125	6.9 gRB 00 D08L 160
	6.6 gRB 000 D08/040	6.6 gRB 000 D08/100	6.6 gRB 000 D08/160
<b>SIBA</b>	20 189 20-50A	20 189 20-125A	20 189 20-160A
<b>WICKMAN</b>	45FEE	140FEE	-
<b>SIEMENS</b>	3NE8 003	3NE8 021	3NC8423-3
<b>LITTELFUSE</b>	-	L70S125	L70S150

**T. H6/4** Fuses to be installed in mains line depending on the compact drive installed.

MANUFACT.	ACD/SCD/CMC				SCD
	1.08	1.15	1.25	2.35/50	2.75
<b>BUSSMANN</b>	FC-6A	FC-12A	FC-20A	FWC-32A10F	-
	XL50-10A	XL50-15A	RF-000-25	FWP-32A14F	-
	6CT	12CT	-	-	-
	FWH-6.30A6F	-	-	-	-
<b>GOULD</b>	ST-6 10x38	ST-12 10x38	ST-20 10x38	-	-
	000-10	000-16	A60x20	-	-
	000/80-10	000/80-16	-	-	-
<b>FERRAZ</b>	6.600CP URC 14.51/6	12.600CP URC 14.51/6	-	-	6.921CP URQ 27x60/63
	6.621CP URC 14.51/6	12.621CP URC 14.51/6	-	-	-
	6.6URE10/6	12.6URE10/6	-	-	-
	A60Q6-2	A60Q12-2	A60Q20-2	A60Q30-2	-
	A60X6-1	A60X12-1	-	-	-
<b>SIBA</b>	-	-	-	-	50-140-34.63 without striker
	-	-	-	-	50 142 34.63 with striker
<b>SIEMENS</b>	-	-	3NE8 015	3NE8 003	-



**WARNING.** Using other protection devices instead of fuses (magneto-thermal switches, for example) does no guarantee proper protection of the equipment.

The fuse references given of the previous table are the ones that may be installed to obtain the maximum power on each model. In those cases where the power supply is oversized, the fuse value should be adjusted to the actual requirements of the machine.



**MANDATORY.** When using an autotransformer or an isolating transformer, the fuses must be selected according to its characteristics depending on the structure of the installation. Therefore, the fuses must be selected specifically for each installation since it will be affected by a variable number of characteristics internal and external to the machine.



DDS  
HARDWARE

Ref.1310

## 6.3 Differential breaker

On a DDS system, fault DC current, practically flat, may come up besides the AC currents and pulsating DC currents. This requires the use of a differential breaker.



**MANDATORY.** Install a universal **type B** breaker (valid for AC, pulsating DC and flattened DC currents) and selective switch-off (delayed switch-off).

*Note. The Siemens® model "5SZ6 468-0KG00", for example.*

These considerations must be taken into account if the differential breaker only affects a machine using a FAGOR DDS servo drive system.



**WARNING.** It is not recommended to use differential breakers sensitive to pulsating currents and, overall, general purpose differential breakers. In this cases, undesired stops might occur due to the high sensitivity of those devices to pulsating currents. **Therefore, never use AC type differential breakers!**



**INFORMATION.** As an alternative, **Type A** differential breakers may be used with selective switch-off. They are more economical than **type B** ones and usually valid for DDS systems with a FAGOR filter. The off current **must not be < 500 mA** and they will have selecting switch-off.

*Note. The Siemens® model "5SM3 645", for example.*

When several machines share the same differential breaker, bear in mind the sum of the leak currents of all the machines involved.



**WARNING.** Watch out for the total leak current when several machines share a differential breaker. All of them may add up to a considerable value!

Note that most of the leak current is due to the mains filter. Hence, it is up to the filter to discharge to ground the noise coming from mains. On the other hand, the leak current of the filters varies depending on mains conditions.

On the filters of the FAGOR catalog, these values may vary between 27 mA (typical value) and 150 mA (maximum value). They practically do not vary with temperature because their components are stable and certified.

The main reason for the variation of the leak current has to do with unbalanced mains voltage or with too many harmonics.

Bear in mind these considerations when installing differential breakers for several machines.

- Verify that the differential breaker to be installed is more immune and admits higher leak currents.
- Distribute the machines connected to each line when installing several differential breakers,
- Use fewer mains filters. Install one filter common to several machines instead of one for each machine. Verify that the machines connected to the same filter do not generate disturbances between them and meet the current regulations.

# 6.

POWER LINE CONNECTION  
Differential breaker

**FAGOR** 

DDS  
HARDWARE

Ref.1310

## 6.4 Isolating transformer or autotransformer

When the mains voltage must be isolated or adapted to the levels required by the DDS system, it may be connected through an isolating transformer or an auto-transformer. This element will also help reduce the amount of harmonics on the line although **it will not guarantee the compliance with the CE regulation.**

**MANDATORY.** When having a mains perfectly referred to ground, auto-transformers may be used to adapt the mains voltage. However, if mains is not referred to ground, an isolating transformer must be used in order to avoid possible dangerous voltage surges on any phase with respect to ground that could damage the equipment.

In this situation, the secondary must have a star configuration with access to the middle point. This middle point of the secondary must be connected to ground or the neuter of mains. This consideration is also applicable to IT type networks.

**MANDATORY.** On systems with an XPS power supply, the inductance of the transformer must be very low and negligible against the inductive value of the choke XPS.

The following figure shows the position where the transformer or autotransformer must be installed within the whole power line connection system.

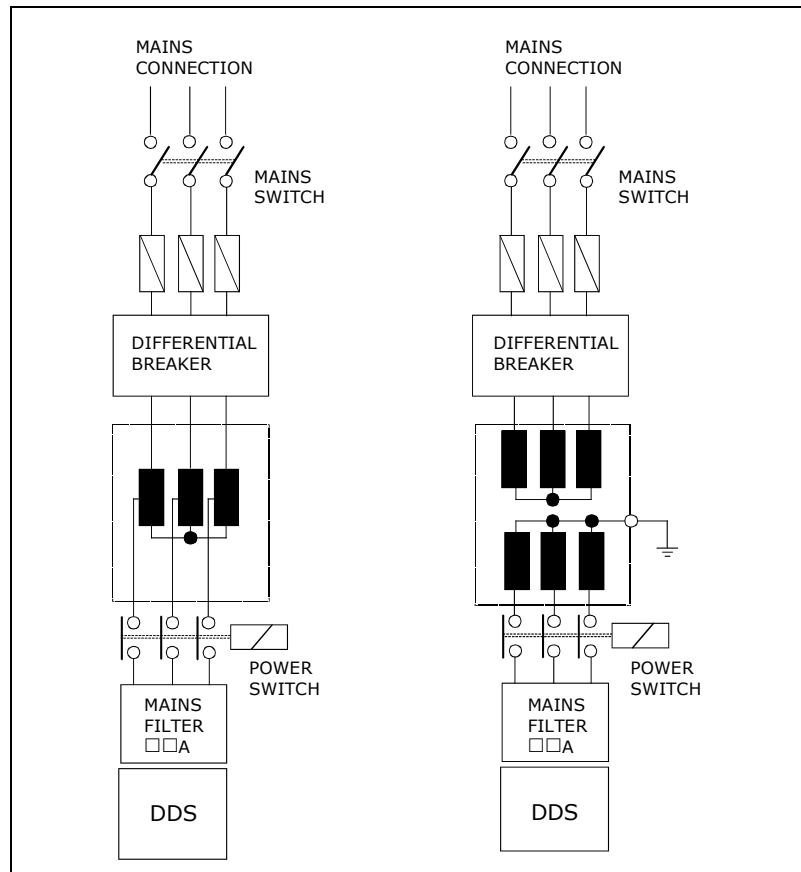

F. H6/2

Position of the autotransformer or isolating transformer.

**MANDATORY.** When using transformers or autotransformers, the main contactor - **KM1** must be connected between them and the DDS system, never on the input line of the transformer or autotransformer.

6.

POWER LINE CONNECTION  
Isolating transformer or auto-transformer



DDS  
HARDWARE

Ref.1310



**MANDATORY.** For machines whose servo drive system includes XPS modules, the transformer or auto-transformer must be properly sized. The rated power of the auto-transformer must be the one resulting from applying the following formula:  $P_n = 1.4 \cdot P_{max}$ , where  $P_{max}$  is the maximum braking power of the system. This power may be, in general, close to the power in the S6 duty cycle of the asynchronous spindle motor. See chapter 5. **SELECTING CRITERIA.**

This means oversizing the transformer or autotransformer considerably in relation to the power of the machine. Hence, individual transformers should not be used for each machine; instead, several machines should be connected to a single transformer. Hence it is possible to apply simultaneity factors and decrease the power required by the transformer or auto-transformer.



**WARNING.** Not complying with the given indications could cause the DDS system to perform poorly.



**INFORMATION.** The mains filter may be installed either before or after the power contactor - **KM1**.



**MANDATORY.** To obtain greater power and accelerations than what the drives can provide, it is necessary to use an auto-transformer to raise the power bus voltage or to have a particular regulated power supply (also called boosting power supply, such as the FAGOR RPS). Remember that these power supplies require chokes installed at the power line input because they are regenerative power supplies.

## 6.

**POWER LINE CONNECTION**  
Isolating transformer or auto-transformer

**FAGOR**

**DDS  
HARDWARE**

**Ref.1310**

## 6.5 Mains filter

# 6.

POWER LINE CONNECTION  
Mains filter



In order for the FAGOR DDS servo drive system to meet the European Directive on Electromagnetic Compatibility 2004/108/CE, a mains filter must be installed against electromagnetic disturbances.

**INFORMATION.** This does not guarantee the compliance with such CE Directive on Electromagnetic Compatibility **regarding the machine** because it may have other devices that could cause disturbances.

To install it, it must be properly connected to ground and the wires connecting to the power supply module must be as short as possible.

They may be installed either horizontally or vertically. The three-phase line is connected to the terminals on top of the module and the load (power supply or compact drive) to those at the bottom. See the label on the front panel showing these terminals in full detail. See figure **F. H6/3**.

Table **T. H6/5** indicates the proper filter to be installed depending on the power supply or compact drive being used in the DDS system.

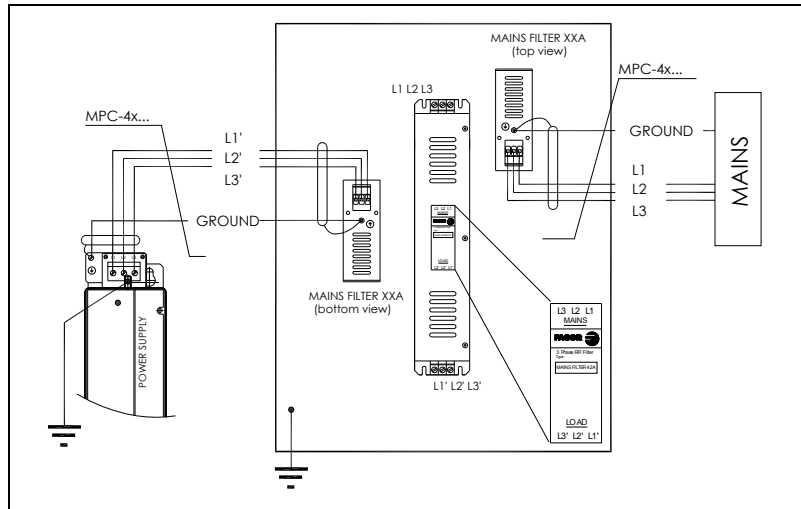

**F. H6/3**

Installation of the MAINS FILTER □□A.



**INFORMATION.** The “MAINS FILTER □□A” may be installed either before or after the power contactor - **KM1**. See figure **F. H6/1**. It is usually installed before the power contactor - **KM1**, but it does not have to be necessarily installed in this position.

**T. H6/5** Mains filter selection according to the power supply or compact drive installed.

Module	MAINS FILTER
XPS-25, RPS-20	42A
PS-25B4	42A
PS-65A, XPS-65, RPS-45, RPS-75	130A
RPS-80	180A
ACD/SCD/CMC 1.08/1.15/1.25	42A
ACD/SCD/CMC 2.35/2.50	42A
SCD 2.75	42A

For further information on mains filters, see section **4.1 Mains filters** of this manual.



DDS  
HARDWARE

Ref.1310

## 6.6 Line inductance

Line inductance means including chokes on each of the three power lines. Its function is to reduce the harmonics generated in mains. The recommended value is given by the formula:

$$L = \frac{V \times 0.04}{2\pi f \times I_{rms}}$$

To simplify the choice, we could consider optimum the values given in the following table:

**T. H6/6** Line inductance selection according to the power supply or compact drive installed.

	PS-25B4	PS-65A	ACD/SCD/CMC 1.08 / 1.15	ACD/SCD/CMC 1.25
<b>L (mH)</b>	1	0.4	5	3
<b>I<sub>rms</sub> (A)</b>	40	100	11	18

When not installing the mains filter, we recommend to use the line inductance in order to minimize disturbances, although is warned that **this inductance does not guarantee the compliance with the CE seal.**



**MANDATORY.** Do not install line chokes in line with RPS or XPS regenerative power supplies. They generate interference in the regenerating mechanism.

6.

POWER LINE CONNECTION  
Line inductance

## 6.7 Types of mains

Depending on the diagram of the electric energy distribution circuit, there are three types of mains: TN, TT and IT.

Depending on the type of mains, the cabling in the electrical cabinet will vary considerably.

We here describe the characteristics and, later on, sample diagrams for a proper installation.

Note that the diagrams provided here do not show the main contactor - **KM1** that must be connected between the transformer or auto-transformer and the DDS servo drive system.

6.

POWER LINE CONNECTION  
Types of mains



DDS  
HARDWARE

Ref.1310

### TN type mains

Distribution diagram that has a point connected directly to ground. The conductive parts of the installation are connected to this point through ground protection wires. This type of mains admits loads between one or several phases and the neuter.

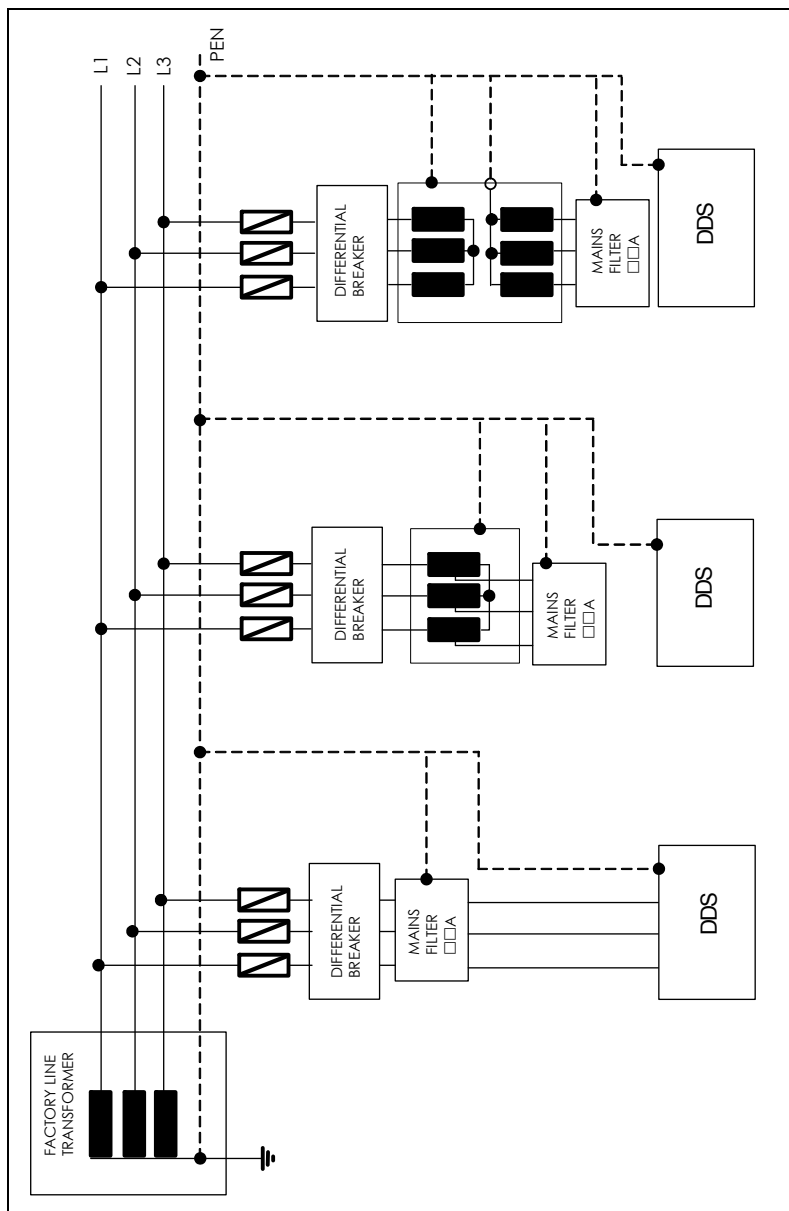

**F. H6/4**

Installation diagram in TN-C type mains.

There are three types of TN systems depending on the protection neuter and ground combination:

- **TN-S diagram** where the neuter and the ground protection conductors are separated throughout the whole length of the system.
- **TN-C-S diagram** where the neuter and the ground protection wire are combined in a single conductor somewhere in the system.
- **TN-C diagram** where the neuter and the ground protection functions are combined in a single conductor throughout the system.



**INFORMATION.** TN type mains are the only ones to which the DDS system can be connected either directly or through an auto-transformer.

See diagram of figure **F. H6/4** for properly installing the DDS system with TN-C type mains distribution.

# 6.

## POWER LINE CONNECTION Types of mains



**DDS  
HARDWARE**

**Ref.1310**

# 6.

## POWER LINE CONNECTION Types of mains

### TT type mains

Distribution diagram that has a point connected directly to ground. The conductive parts of the installation are connected to this ground point independently from the ground electrode of the power supply system.

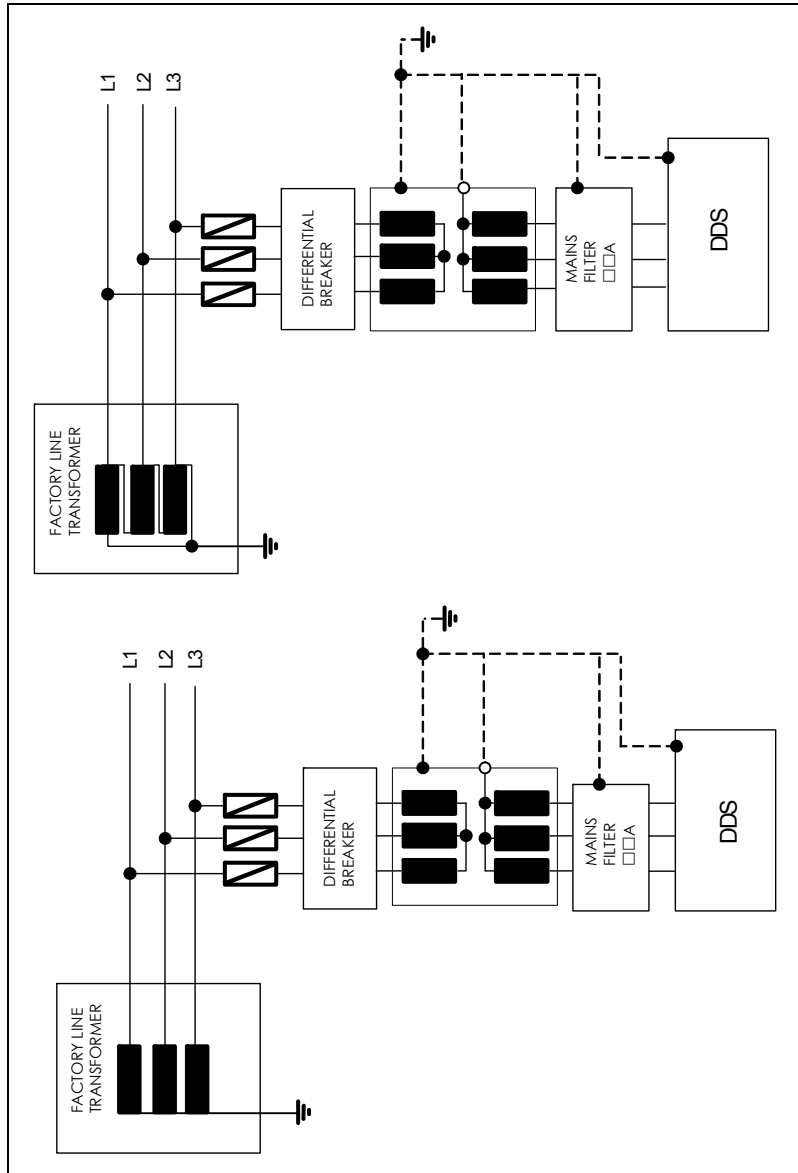

**F. H6/5**

Installation diagram in a TT type mains.



DDS  
HARDWARE

Ref.1310

### IT type mains

Distribution diagram that has no point connected directly to ground. The conductive parts of the installation are connected to ground.

In this type of mains, the differential breaker is used assuming that the capacitance of mains with respect to ground is large enough to ensure that a minimum fault current flows with the same magnitude as that of the operating differential current assigned. Otherwise, its use is not necessary.

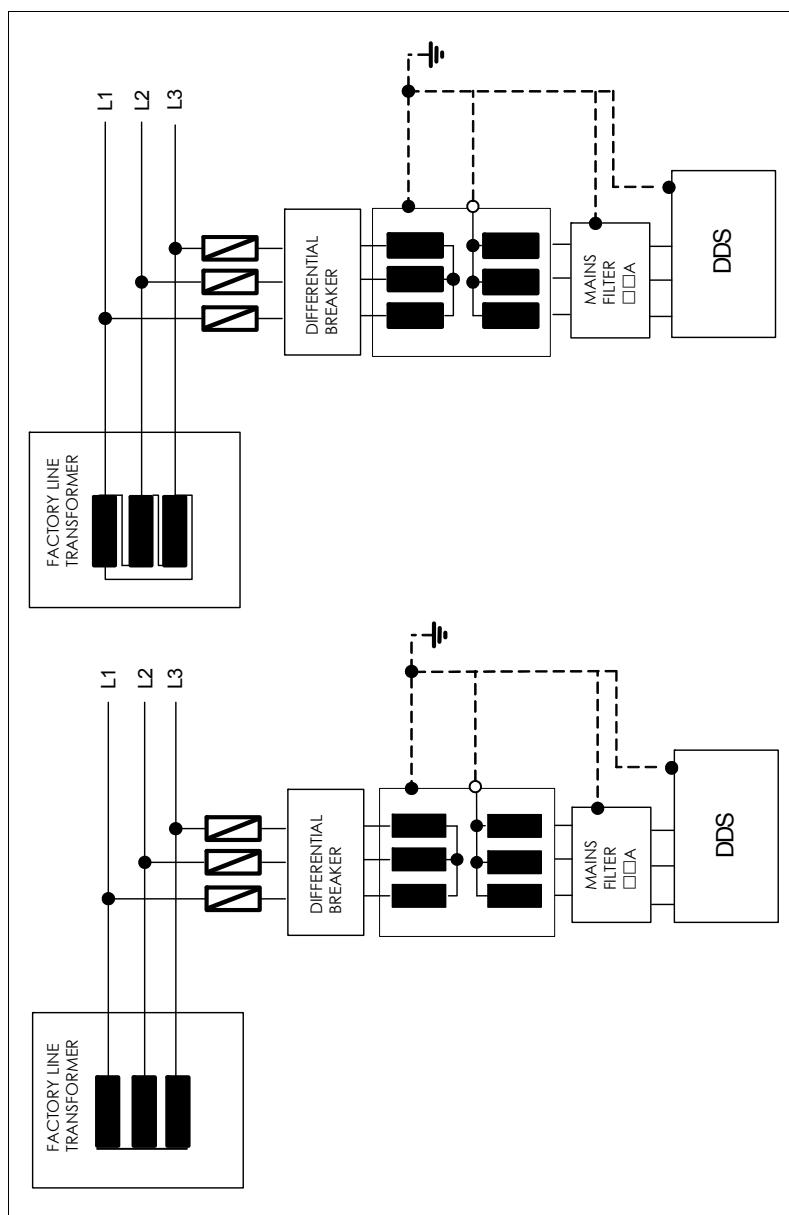

**F. H6/6**

Installation diagram of an IT type mains.



**INFORMATION.** Note that an IT type mains can also be controlled through an isolation watching device. Both protection measurements are compatible with each other.

# 6.

**POWER LINE CONNECTION**  
Types of mains



**DDS  
HARDWARE**

Ref.1310

## 6.8 Mains connection cables

For further information on the mains cabling for the DDS system, see chapter 7. **CABLES**, section 7.1 **Mains connection cable. Power supply - mains connection.**

6.

**POWER LINE CONNECTION**  
Mains connection cables



DDS  
HARDWARE

Ref.1310

This chapter describes the cables needed to install the DDS servo drive system and the characteristics of the connectors of those cables. It also describes the mechanical characteristics of those cables.

Previous chapters of this manual already described the cabling of the DDS system for the power lines, feedback, optic fiber of the SERCOS ring or CAN bus connection, RS-232/422 serial line connection, communications etc.

The attached table **T. H7/1** gathers the regulation applicable to typical installation of drive systems.

It determines the minimum section of the cable through which the maximum current allowed in continuous duty can circulate on three-phase wires in PVC hoses or installed on the machine through conduits or channels according to EN 60204-1.

The ambient temperature is assumed to be 40 °C (104 °F).



**MANDATORY.** The dielectric insulation of the cable must be enough to withstand the test voltage at a minimum of 2000 V AC for 5 minutes for cables supporting voltages over 50 V AC (alternating current) or 120 V DC (direct current). Refer to the recommendations of the cable manufacturer before doing the installation.

**T. H7/1** Cable section / I<sub>max</sub> current.

Section (mm <sup>2</sup> )	I <sub>max</sub> (Arms)
0.75	8.5
1.0	10.1
1.5	13.1
2.5	17.4
4	23
6	30
10	40
16	54
25	70
35	86
50	103
70	130
95	156
120	179

## 7.1 Mains connection cable. Power supply - mains connection

Refer to table **T. H5/14** of chapter 5 to determine the cable needed to connect the power supply to mains. Note that compact drives have it integrated into them.

The table **T. H7/2** shows the mains connection cable supplied by FAGOR and their sales reference is MPC-□x□.

**T. H7/2** Range of mains connection cables.

MPC-4x1.5	MPC-4x4	MPC-4x10	MPC-4x25	MPC-4x50
MPC-4x2.5	MPC-4x6	MPC-4x16	MPC-4x35	MPC-4x70

The 4 wires of the mains cable must be connected to the power supply or to the compact drive (integrated power supply) as shown in figure **F. H7/1**.

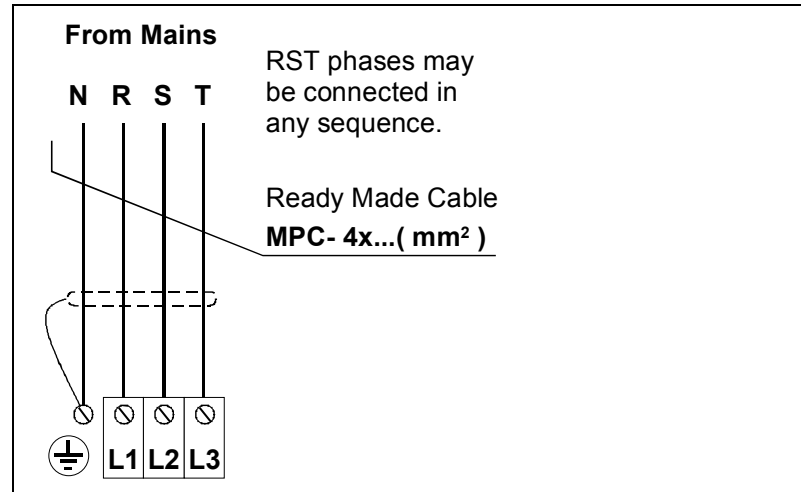

**F. H7/1**

MPC cable connection from the power supply or compact drive to mains.

### Power leads. Mechanical characteristics

The following table shows the mechanical characteristics of the terminals (L1, L2, L3, PE) at the power supplies and at the compact drives.

**T. H7/3** Mechanical characteristics of the power connectors for the power supplies and compact drives.

Module	Gap (mm)	Max. tightenin torque (N·m)	Max. hole section (mm <sup>2</sup> )	Min. cable section (mm <sup>2</sup> )
PS-65A	18.8	7	70	50
PS-25B4	10.1	1.5	16	10
XPS-25	12.1	2	16	10
XPS-65	18.8	7	70	50
RPS-80	25.0	20	95	70
RPS-75	25.0	20	95	70
RPS-45	18.8	7	70	35
RPS-20	10.6	1.5	16	10
ACD/SCD/CMC 1.08/1.15	7.62	0.5	4	2.5
ACD/SCD/CMC 1.25	7.62	0.7	6	4
ACD/SCD/CMC 2.35/2.50	10.16	1.2	6	6
SCD 2.75	10.16	1.5	16	10

7.

CABLES

Mains connection cable. Power supply - mains connection



DDS  
HARDWARE

Ref.1310

## 7.2 Power cable. Motor-drive connection

Table T. H7/4 and table T. H7/5 show the range of power cables supplied by FAGOR to connect a motor and a drive. **They are supplied without connectors** because the power connector will usually be different depending on the motor it will be connected to. The number of meters available upon request. It is available in lengths of 5, 10, 15, 20, 30, 40, 50, 75, 100, 150, 200, 250 and 300 meters for sections up to 10 mm<sup>2</sup> (included) and 5, 7, 10, 12, 15, 20, 25, 30, 35, 40, 45, 50, 75 and 100 for sections of up to 50 mm<sup>2</sup> (included). Their sales reference is:

MPC-4x□	to connect motors without brake
MPC-4x□+(2x□)	to connect motors with brake

**T. H7/4** Range of cables to connect a motor (without brake) and a drive.

MPC-4x1.5	MPC-4x4	MPC-4x10	MPC-4x25	MPC-4x50
MPC-4x2.5	MPC-4x6	MPC-4x16	MPC-4x35	MPC-4x70

**T. H7/5** Range of cables to connect a motor (with brake) and a drive.

MPC-4x1.5+(2x1)	MPC-4x6+(2x1)	MPC-4x25+(2x1)
MPC-4x2.5+(2x1)	MPC-4x10+(2x1)	
MPC-4x4+(2x1)	MPC-4x16+(2x1.5)	



**INFORMATION.** Remember that when a motor is mentioned here, it refers to any motor of the FAGOR catalog, both synchronous and asynchronous.



**MANDATORY.** In order for the system to comply with the European Directive on Electromagnetic Compatibility, the cable hose that carries 6 or 4 cables, depending on whether the motor has a brake or not, must be shielded and connected at both ends; i.e. both at the drive end and at the motor end. This condition is a must.

### Power terminals. Mechanical characteristics

The mechanical characteristics of the terminals (U, V, W, PE) on modular drives are:

**T. H7/6** Mechanical characteristics of the power connectors of the modular drives.

Module	Gap (mm)	Max. tightening torque (N·m)	Max. hole section (mm <sup>2</sup> )	Min. cable section (mm <sup>2</sup> )
AXD/SPD/MMC 1.08/1.15	7.62	0.6	4	2.5
AXD/SPD/MMC 1.25	7.62	0.8	6	6
AXD/SPD/MMC 1.35	10.16	1.5	6	6
AXD/SPD/MMC 2.□□	10.16	1.8	16	16
SPD 2.85	10.16	1.8	16	16
AXD/SPD/MMC 3.100	-	8	50	25
AXD/SPD/MMC 3.150	-	8	50	50
SPD 3.200	-	20	95	70
SPD 3.250	-	20	95	95



**MANDATORY.** The cable wires connected at the motor end must be kept inside their corresponding connector. The connector will be different depending on the user's motor.

For further details on the connector that must be mounted at the end of the MPC cable and connected at the motor end, see the manual of the corresponding motor.

7.

CABLES

Power cable. Motor-drive connection



DDS  
HARDWARE

Ref.1310

**7.**

**CABLES**  
Power cable. Motor-drive connection

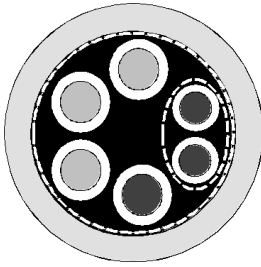

**Cable MPC- 4xO+(2xO). Mechanical characteristics**

**T. H7/7** Mechanical characteristics of the MPC-□x□+(□x□) cable.

Type	Shield. It ensures EMC Compatibility.
Flexibility	High. Special to be used in cable carrying chains with a bending radius of 10 times the Dmax under dynamic conditions and 6 times the Dmax under static conditions.
Covering	PUR. Polyurethane resistant to chemical agents used in machine-tools.
Temperature	Work: - 20°C to + 60°C (- 4°F to 140°F) Storage: - 50°C to + 80°C (- 58°F to 176°F)
Rated voltages	Uo/U: 600/1000 Volts.

**MPC- 4xO+(2xO) cable selection**

To select the cable needed for the power connection between the drive and the motor, see the manual of the corresponding motor that indicates the necessary cable depending on the user's motor.



DDS  
HARDWARE

Ref.1310

### 7.3 Motor feedback cables

The attached tables show the range of motor encoder cables supplied by FAGOR to connect the motor feedback and a drive. They are supplied with connectors at both ends (see note below) and their sales reference is:

Motor	Ref. Cable	Motor feedback
FXM, FKM	EEC-SP-□	1 Vpp sinusoidal encoder
	IECD-□	Incremental TTL encoder
FM7	EEC-FM7-□	Incremental TTL encoder
	EEC-FM7S-□	Incremental TTL encoder (better immunity and flexibility)
	EEC-FM7CS-□	C axis SinCos encoder

**Note.** None of the motor encoder feedback cables for FM7 spindle motors will have the connector mounted at the motor end; a connector will be supplied with the cable for the user to mount it. See the manual: AC spindle motor - FM7/FM9 - for further detail on how to mount it.



**INFORMATION.** The encoder cable (without connectors) is only available upon request in lengths of 75, 100 150 m.

#### EEC-SP-□ cable

**T. H7/8** Range of EEC-SP-□ cables. The number indicates their length in meters including the connectors.

EEC-SP- 5	EEC-SP-15	EEC-SP-25	EEC-SP-35	EEC-SP-45
EEC-SP-10	EEC-SP-20	EEC-SP-30	EEC-SP-40	EEC-SP-50

For further detail on how to connect the drive, see the manual of the corresponding motor.



**INFORMATION.** Remember that using the cable reference EEC-SP-□ does guarantee compliance with the Directive on Electromagnetic Compatibility (EMC).

#### IECD-□ cable

**T. H7/9** Range of IECD-□ cables. The number indicates their length in meters including the connectors.

IECD- 5	IECD-10	IECD-15	IECD-20	IECD-25
---------	---------	---------	---------	---------

For further detail on how to connect the drive, see the manual of the corresponding motor.

#### EEC-FM7-□ cable

**T. H7/10** Range of EEC-FM7-□ cables. The number indicates their length in meters including the connector.

EEC-FM7- 5	EEC-FM7-10	EEC-FM7-15	EEC-FM7-20	EEC-FM7-25
------------	------------	------------	------------	------------

For further detail on how to connect the drive, see the manual of the corresponding motor.

#### EEC-FM7S-□ cable

**T. H7/11** Range of EEC-FM7S-□ cables. The number indicates their length in meters including the connector.

EEC-FM7S-3	EEC-FM7S-15	EEC-FM7S-30	EEC-FM7S-45
EEC-FM7S-5	EEC-FM7S-20	EEC-FM7S-35	EEC-FM7S-50
EEC-FM7S-10	EEC-FM7S-25	EEC-FM7S-40	

For further detail on how to connect the drive, see the manual of the corresponding motor.

**7.**  
CABLES  
Motor feedback cables



DDS  
HARDWARE

Ref.1310

**EEC-FM7CS-□ cable**

**T. H7/12** Range of EEC-FM7CS-□ cables. The number indicates their length in meters including the connector.

EEC-FM7CS- 5	EEC-FM7CS-20	EEC-FM7CS-35	EEC-FM7CS-50
EEC-FM7CS-10	EEC-FM7CS-25	EEC-FM7CS-40	
EEC-FM7CS-15	EEC-FM7CS-30	EEC-FM7CS-45	

For further detail on how to connect the drive, see the manual of the corresponding motor.

**7.**

**CABLES**  
Motor feedback cables



DDS  
HARDWARE

Ref.1310

## 7.4 Direct feedback cable

The direct feedback is given by an external linear encoder (scale) or rotary encoder that may be incremental (with reference signals) or absolute (with reference signals).

### External incremental feedback

The attached figure shows the cable of the direct feedback supplied by FAGOR to connect an incremental feedback device (external linear or rotary) with FAGOR sinusoidal signals (1 Vpp) or square signals (differential TTL) and the drive. **This cable is supplied with connectors at both ends** and its sales reference is:

#### EC-□ PD cable

**T. H7/13** Range of EC-□ PD cables. The number indicates their length in meters including the connectors.

EC-1 PD	EC-3 PD	EC-6 PD	EC-9 PD	EC-12 PD
EC-2 PD	EC-4 PD	EC-8 PD	EC-10 PD	

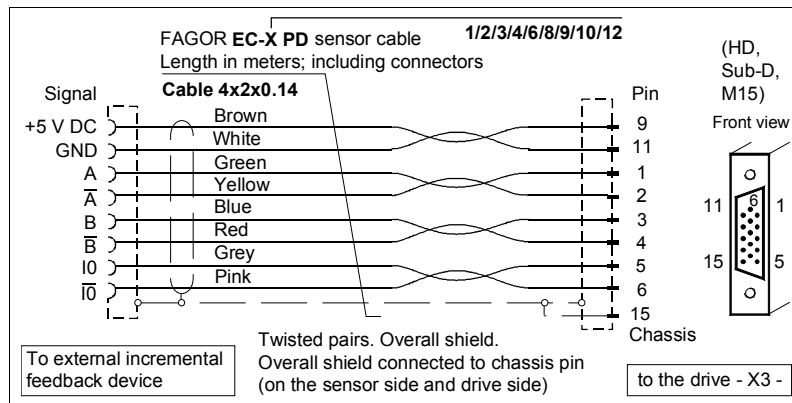

#### F. H7/2

Diagram of the direct feedback cable for an external FAGOR incremental feedback (linear or rotary) sinusoidal (1 Vpp) or square-wave (differential TTL).

### External absolute feedback

The attached figure shows the cable of the direct feedback supplied by FAGOR to connect an external FAGOR absolute linear encoder) with sinusoidal signals (1 Vpp) and the drive. This cable **is supplied with connectors at both ends** and its sales reference is:

#### EC-□B-D cable

**T. H7/14** Range of EC-□B-D cables. The number indicates their length in meters including the connectors.

EC-1B-D	EC-3B-D	EC-6B-D	EC-9B-D
---------	---------	---------	---------

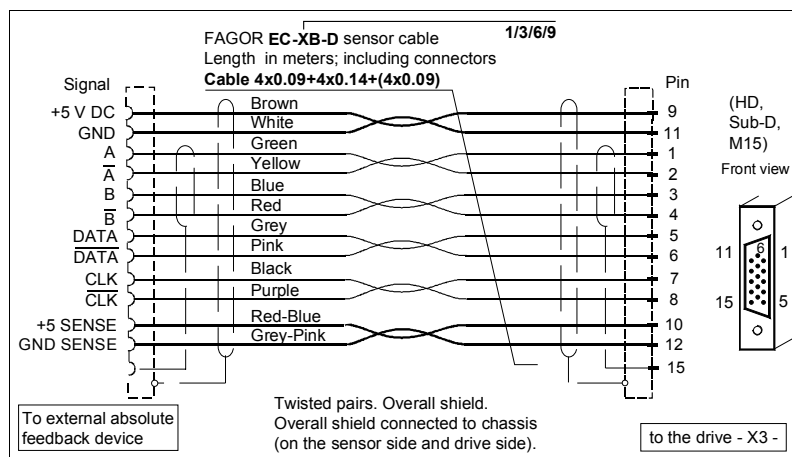

#### F. H7/3

Diagram of the direct feedback cable for the FAGOR absolute linear encoder.

7.

CABLES  
Direct feedback cable



DDS  
HARDWARE

Ref.1310

**7.**

**CABLES**  
Direct feedback cable

**External Stegmann sinusoidal encoder**

FAGOR does not supply the direct feedback cable for connecting an external Stegmann sinusoidal encoder **with the drive**. For this connection, you must know the pinout at the encoder end and match it with the pinout at the drive end. With this information, the user will be able to make the connection and make his own cable.

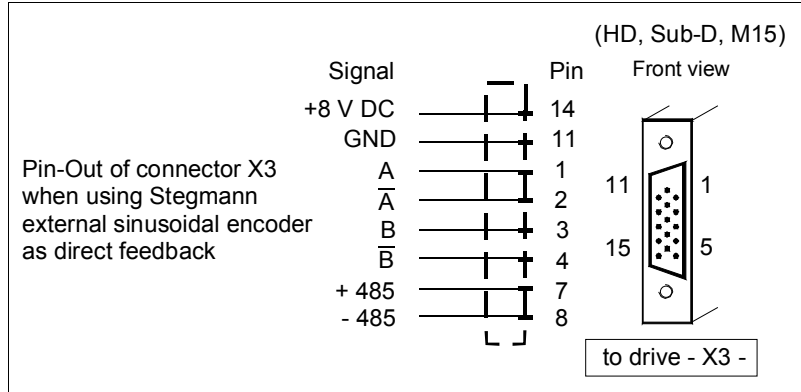

**F. H7/4**

Pinout for the direct feedback cable when using a Stegmann sinusoidal encoder as external feedback.



DDS  
HARDWARE

Ref.1310

## 7.5 Signal cables for control and communications

### Encoder simulator from the drive to the CNC

Depending on motor feedback, the drive can generate a set of signals that simulate those of a differential TTL encoder attached to the rotor of the motor. The attached tables show this cable supplied by FAGOR to connect the drive (X3) and the CNC 8055 (X1, X2, X3 or X4) / 8055i (X10, X11, X12 or X13) / 8065/8070 (LOCAL COUNTER 1/2). The attached tables show this cable supplied by FAGOR to connect the drive and the CNC. They are supplied with connectors at both ends and their sales reference is:

#### SEC-HD-□ cable

**T. H7/15** Range of SEC-HD-□ cables. The number indicates their length in meters including the connectors.

SEC-HD-1	SEC-HD-10	SEC-HD-25
SEC-HD-3	SEC-HD-15	SEC-HD-30
SEC-HD-5	SEC-HD-20	SEC-HD-35

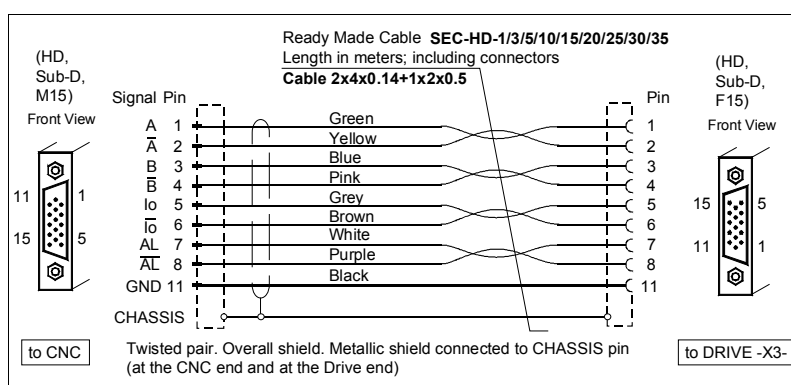

#### F. H7/5

Connection of the cable for the encoder simulation and the CNC.



**INFORMATION.** The max. length for SEC-HD-□ cables for best performance is 50 meters.

7.

CABLES  
Signal cables for control and communications

# 7.

CABLES  
Signal cables for control and communications

## SERCOS optical fiber

Fagor Automation supplies the fiber optic cables for SERCOS communications between the group of drives and the CNC in a ring connection and in lengths ranging from 1 to 100 meters. The cables between drives come with the connectors for each module. For SERCOS connection **under 40 m**, use the fiber optic cable with polymer core.

Its sales references are:

### SFO-□ cable

**T. H7/16** Range of SFO-□ cables. The number indicates their length in meters.

SFO-1	SFO-2	SFO-3	SFO-5	SFO-7	SFO-10	SFO-12
-------	-------	-------	-------	-------	--------	--------

### SFO-FLEX-□ cable

**T. H7/17** Range of SFO-FLEX-□ cables. The number indicates their length in meters.

SFO-FLEX-10	SFO-FLEX-20	SFO-FLEX-30	SFO-FLEX-40
SFO-FLEX-15	SFO-FLEX-25	SFO-FLEX-35	



**INFORMATION.** The max. length for fiber optic cables of the references mentioned earlier for best performance is 40 meters.

### Mechanical characteristics of the SFO-□ cable

**T. H7/18** Mechanical characteristics of the SFO-□ cable.

Flexibility	Normal. It must only be used in systems under static conditions where the minimum bending radius is 30 mm. Use only in static conditions!
Covering	PUR. Polyurethane resistant to chemical agents used in machine-tools.
Temperature	Work: - 20°C to + 80°C (- 4°F to 176°F) Storage: - 35°C to + 85°C (- 31°F to 185°F)

### Mechanical characteristics of the SFO-FLEX-□ cable

**T. H7/19** Mechanical characteristics of the SFO-FLEX-□ cable.

Flexibility	High. Special for cable-carrying chains with a minimum bending radius, in dynamic conditions, is 70 mm. Use only in dynamic conditions!
Covering	PUR. Polyurethane resistant to chemical agents used in machine-tools.
Temperature	Work: - 20°C to +70°C (- 4°F to 158°F) Storage: - 40°C to +80°C (- 40°F to 176°F)



**INFORMATION.** The SFO-FLEX-□ fiber optic cables are compatible with the SFO-□ cables. The SFO-FLEX-□ are more flexible.

**NOTE.** If the fiber optic cable for SERCOS communication between modules is going to be moving (dynamic conditions), **always** use the SFO-FLEX-□ cable. The SFO-□ cable will be enough for static conditions (resting). The useful life span of a SFO-□ cable cannot be guaranteed if it is installed in applications where it works under dynamic conditions (moving).

For SERCOS connection **over 40 m**, use the fiber optic cable with glass core.



DDS  
HARDWARE

Ref.1310

Their sales reference is:

**SFO-V-FLEX-□ cable**

**T. H7/20** Range of SFO-V-FLEX-□ cables. The number indicates their length in meters.

SFO-V-FLEX-40	SFO-V-FLEX-60	SFO-V-FLEX-100
SFO-V-FLEX-50	SFO-V-FLEX-75	

**Mechanical characteristics**

**T. H7/21** Mechanical characteristics of the SFO-V-FLEX-□ cable.

Flexibility	The minimum bending radius will be 60 mm in dynamic conditions and 45 in static conditions.
Covering	PUR. Polyurethane resistant to chemical agents used in machine-tools.
Temperature	Work: - 40°C to +80°C (- 40°F to 176 °F) Storage: - 40°C to +80°C (- 40°F to 176°F )

**7.**

**CABLES**  
Signal cables for control and communications



**DDS  
HARDWARE**

**Ref.1310**

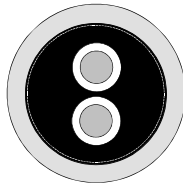

**7.**

**CABLES**  
Signal cables for control and communications

**CAN cable**

Cable supplied by Fagor Automation upon request. It is used to establish communication through a CAN field bus between drives and a master device (CNC, PC, ESA panel, etc.). It consists of a pair of twisted wires with a section of 0.25 mm<sup>2</sup>, overall shield and impedance of 120 Ω. It is supplied without connectors. It comes in lengths from 5 m to 150 m, in multiples of 5 m.

Its sales references are:

**CAN CABLE □M**

**T. H7/22** Range of CAN CABLE □M cables. The number indicates length in meters.

CAN CABLE 5M	CAN CABLE 30M	CAN CABLE 75M
CAN CABLE 10M	CAN CABLE 35M	CAN CABLE 100M
CAN CABLE 15M	CAN CABLE 40M	CAN CABLE 150M
CAN CABLE 20M	CAN CABLE 45M	
CAN CABLE 25M	CAN CABLE 50M	

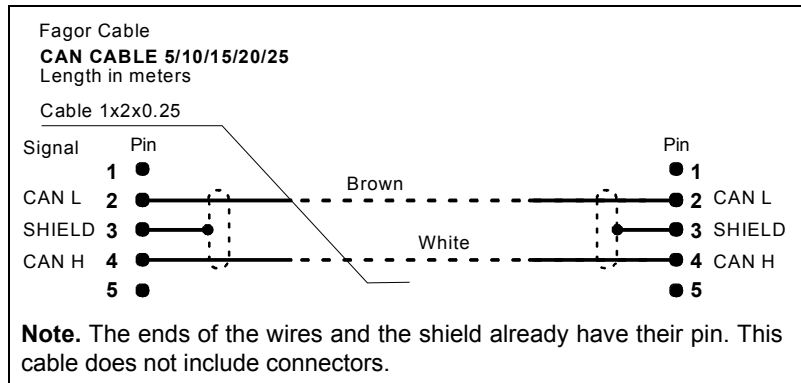

**F. H7/6**

CAN cable.

**Mechanical characteristics**

**T. H7/23** Mechanical characteristics of the CAN CABLE □M cable.

Type	Shield. It ensures EMC compatibility
Ext. Diameter	Øext = 6.3 mm
Flexibility	High. Special to be used in cable carrying chains with a bending radius of 15 times the Øext under dynamic conditions and 8 times the Øext under static conditions.
Covering	PUR. Polyurethane resistant to chemical agents used in machine-tools.
Temperature	Work: -30°C to +70°C (-22°F to 158°F) Storage: -5°C to +70°C (23°F to 158°F)
Rated voltages	Uo / U: 250/1000 Volts



**DDS  
HARDWARE**

**Ref.1310**

## 7.6 RS232/RS422 BE adapter

Before showing other connections, it shows the RS232/RS422 BE adapter and the pinout for each end.

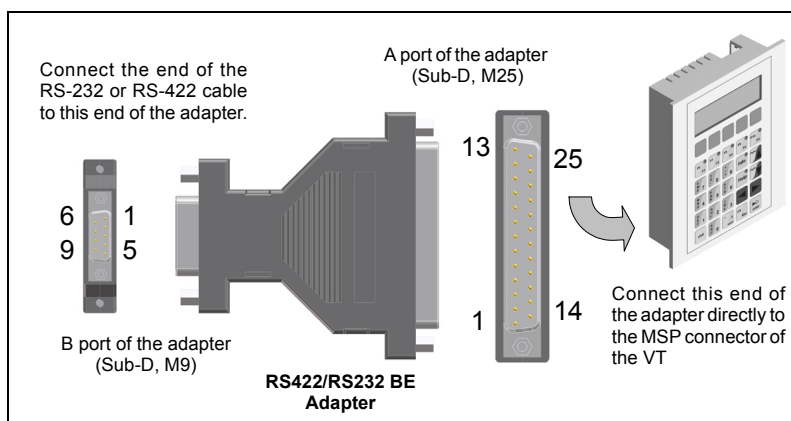

### F. H7/7

RS232/RS422 BE adapter.

### T. H7/24 Description of the pinout of port B connector.

1	N.C. (not connected)
2	T x RS232 OUT
3	R x RS232 IN
4	N.C. (not connected)
5	RS232 GND
6	R x RS422 + IN
7	R x RS422 - IN
8	T x RS422 + OUT
9	T x RS422 - OUT

**NOTE.** The pinout for port A is the same as for the MSP port of the VT panel from ESA.

### T. H7/25 Description of the pinout of port A connector.

1	N.C. (not connected)	14	IKT OUT
2	T x RS232 OUT	15	IKR OUT
3	R x RS232 IN	16	+ 5 V DC (reserved)
4	RTS RS232 OUT	17	N.C. (not connected)
5	CTS RS232 IN	18	* R x C.L. + IN
6	N.C. (not connected)	19	N.C. (not connected)
7	GND	20	N.C. (not connected)
8	N.C. (not connected)	21	N.C. (not connected)
9	* T x C.L. + OUT	22	T x R x 485 + IN / OUT
10	T x R x 485 - IN / OUT	23	T x RS422 + OUT
11	* T x C.L. -OUT	24	R x RS422 - IN
12	T x RS422 - OUT	25	* R x C.L. - IN
13	R x RS422 + IN		

\* C. L. : Current loop.

7.

CABLES  
RS232/RS422 BE adapter



DDS  
HARDWARE

Ref.1310

## 7.7 RS-232 serial line

**FAGOR does NOT supply these cables.** Nevertheless, these are the connection diagrams. Note that the RS232/RS422 BE adapter may be used to connect the RS-232 or RS-422 serial line with a VT panel from ESA.

**NOTE.** The user is free to use this FAGOR adapter or not. But, it should be used unless indicated otherwise because it makes the connection easier.

# 7.

CABLES  
RS-232 serial line

### RS-232 serial line between a PC and a drive

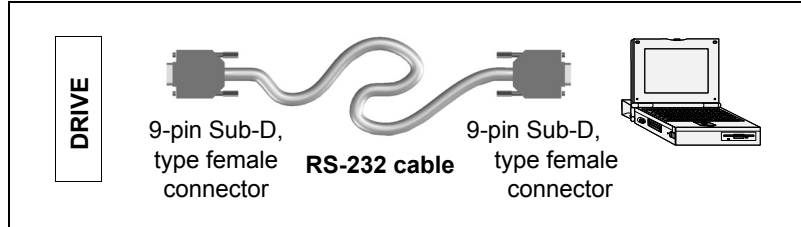

#### F. H7/8

RS-232 serial line connection between a PC and a drive.

The following connections may be used:

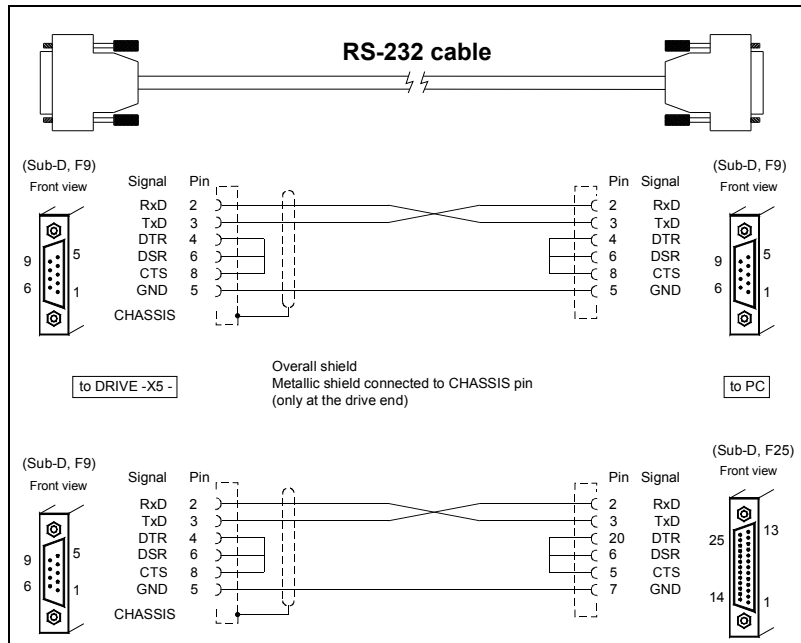

#### F. H7/9

RS-232 serial line cable between a PC and a drive.

**NOTE.** The metallic shield must be soldered to the hood of the connector at the drive end. The user must NOT connect the “reserved” pins anywhere.

It is up to the user to use the RS422/RS232 BE adapter or not for the connection. The following sections show all the connection possibilities.

### RS-232 serial line cable between a PC and a VT from ESA

This VT-PC connection is essential for transferring the communication driver and the project.

The connection cable to use will depend on whether the adapter RS232/RS422 BE is used or not.



DDS  
HARDWARE

Ref.1310

**PC-VT connection using an RS-232 cable (without adapter)**

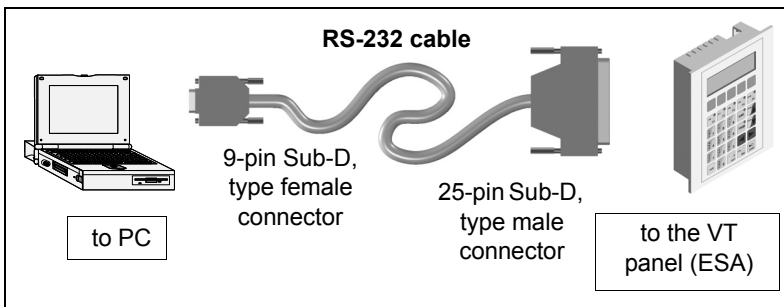

**F. H7/10**

RS-232 serial line connection between a PC and VT from ESA (without adapter).

The connection cable when not using the adapter RS232/RS422 BE has the following connectors at its ends:

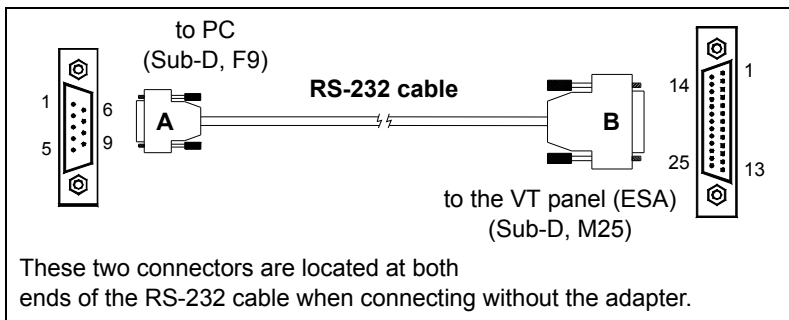

These two connectors are located at both ends of the RS-232 cable when connecting without the adapter.

**F. H7/11**

- A.** Connector of the RS-232 cable for direct connection to the PC.
- B.** Connector of the RS-232 cable for direct connection to the VT panel from ESA.

The connection is:

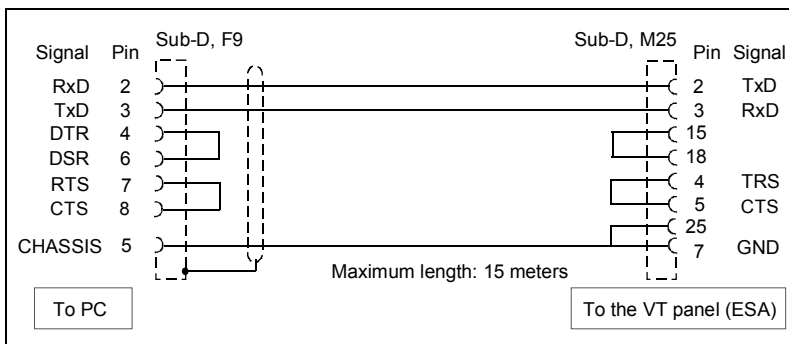

**F. H7/12**

RS-232 connection between PC and VT without adapter.

**NOTE.** See the previous section for further information on the pinout of the 25-pin connector of the MSP port of the VT panel from ESA .

**7.**

CABLES  
RS-232 serial line



DDS  
HARDWARE

Ref.1310

# 7.

CABLES  
RS-232 serial line

## PC-VT connection using an RS-232 cable (with adapter)

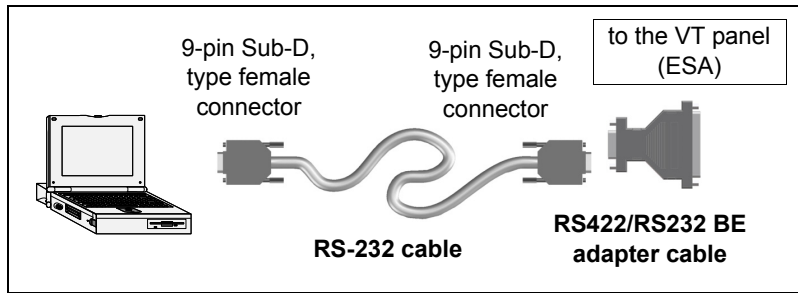

### F. H7/13

RS-232 serial line connection between a PC and VT from ESA (with adapter).

The adapter RS232/RS422 BE has the following connectors at its ends:

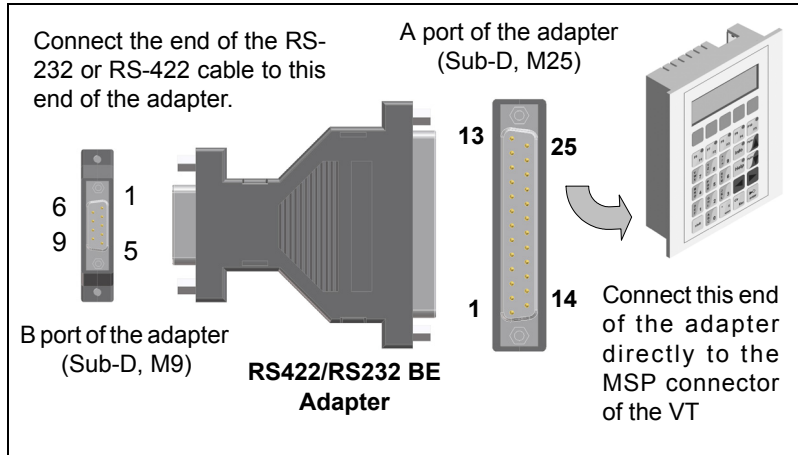

### F. H7/14

RS232/RS422 BE adapter.

The connection cable when using the adapter RS232/RS422 BE will have the following connectors at its ends:

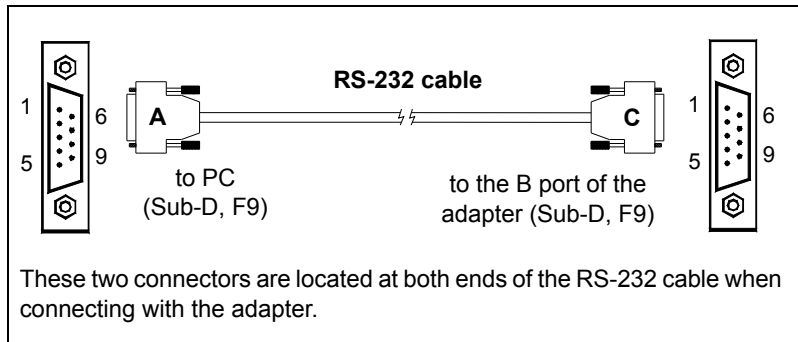

### F. H7/15

A. Connector of the RS-232 cable for direct connection to the PC.

C. Connector of the RS-232 cable to connect to the B port of the adapter.

The connection is:

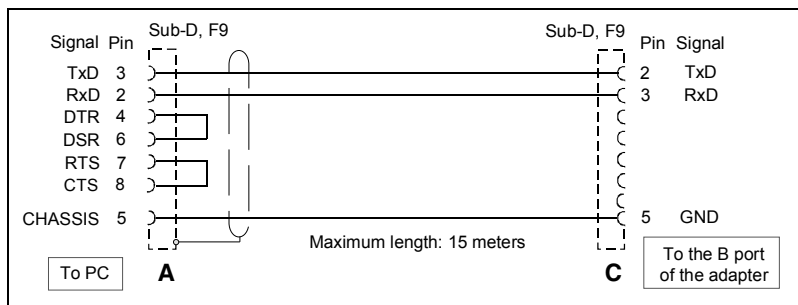

### F. H7/16

RS-232 connection between PC and VT with adapter.



DDS  
HARDWARE

Ref.1310

### RS-232 serial line cable between a VT and a drive

Once the project has been transferred from the PC to the VT (ESA), the video terminal may be connected to a single drive, hence establishing communication via the MSP serial port of the VT and the drive's RS-232 serial port.

**NOTE.** When mentioning a drive, it means any model of the FAGOR catalog, i.e. AXD, SPD, ACD, SCD, MMC and CMC models.

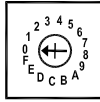

**MANDATORY.** The RS-232 serial line can only be used between the ESA VT and a single drive. The arrow of the drive's node selecting rotary switch (Node\_Select) must be pointing at 0.

It is now possible to handle and control from the Video Terminal the process application by communicating with the connected drive. The connection cable to be used is described next.

**NOTE.** The adapter RS232/RS422 BE is not required in any case.

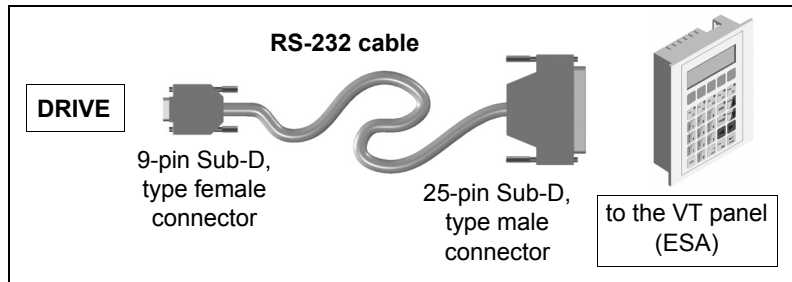

#### F. H7/17

RS-232 serial line connection between the VT from ESA and a drive (without adapter).

The connection cable has the following connectors at its ends:

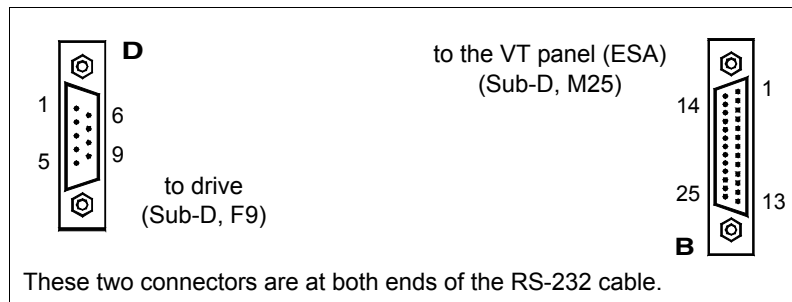

These two connectors are at both ends of the RS-232 cable.

#### F. H7/18

**D.** Connector of the RS-232 cable for direct connection to the drive.

**B.** Connector of the RS-232 cable for direct connection to the VT from ESA.

The connection is:

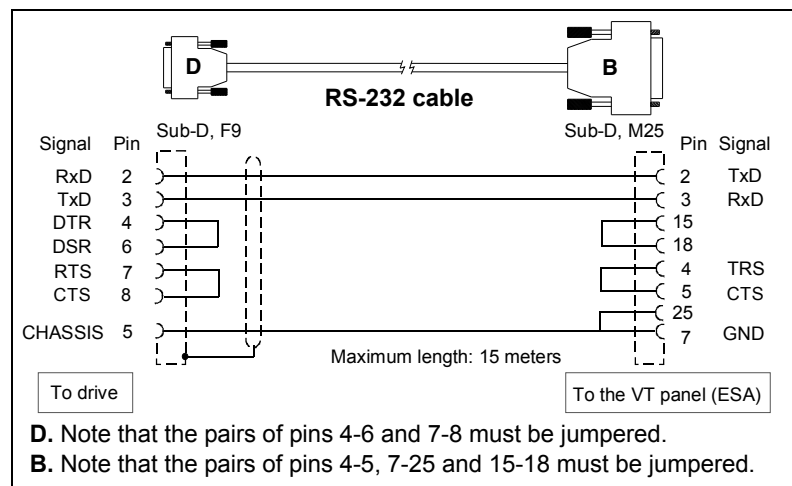

**D.** Note that the pairs of pins 4-6 and 7-8 must be jumpered.

**B.** Note that the pairs of pins 4-5, 7-25 and 15-18 must be jumpered.

#### F. H7/19

RS-232 connection between a VT and a drive (without adapter).

# 7.

CABLES  
RS-232 serial line



DDS  
HARDWARE

Ref.1310

## 7.8 RS-422 serial line

**FAGOR does NOT supply these cables.** Nevertheless, these are the connection diagrams. Note that the RS232/RS422 BE adapter may be used to connect the RS-232 or RS-422 serial line with a VT panel from ESA.

**NOTE.** The user is free to use this FAGOR adapter or not. But, it should be used unless indicated otherwise because it makes the connection a lot easier.

### RS-422 serial line cable between a VT and several drives (without adapter)

**NOTE.** Only for MMC or CMC drives.

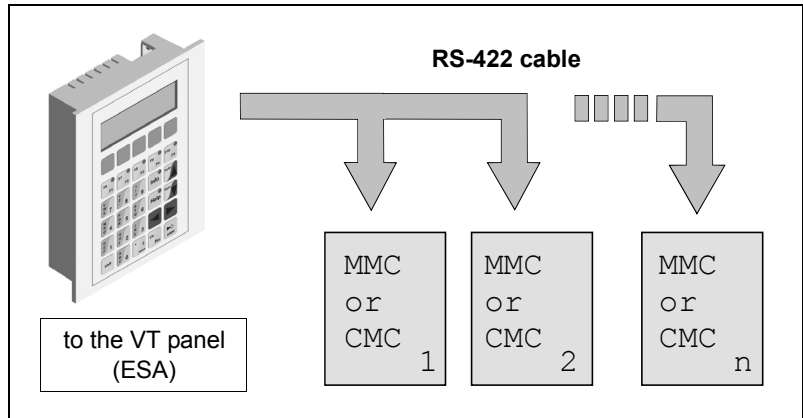

#### F. H7/20

RS-422 serial line connection between a VT from ESA and several MMC or CMC drives (without adapter).

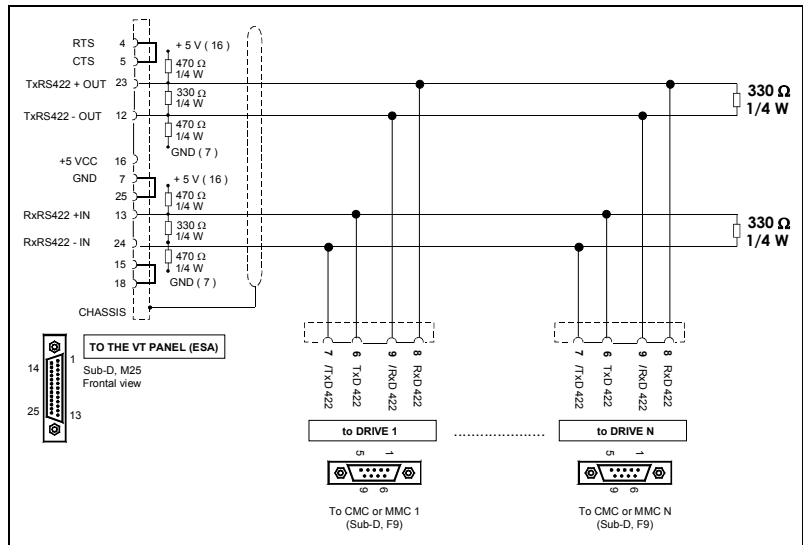

#### F. H7/21

RS232 serial line cable between a VT from ESA and several MMC or CMC drives (without adapter).

If the user chooses to use the **RS232/RS422 BE adapter**, the RS-422 serial line must be connected as instructed in the following section. This chapter has already described all the details on this adapter as well as the pinouts of its ends.

**7.**  
**CABLES**  
RS-422 serial line



DDS  
HARDWARE

Ref.1310

**RS-422 serial line cable between a VT and several drives (with adapter)**

**NOTE.** Only for MMC or CMC drives.

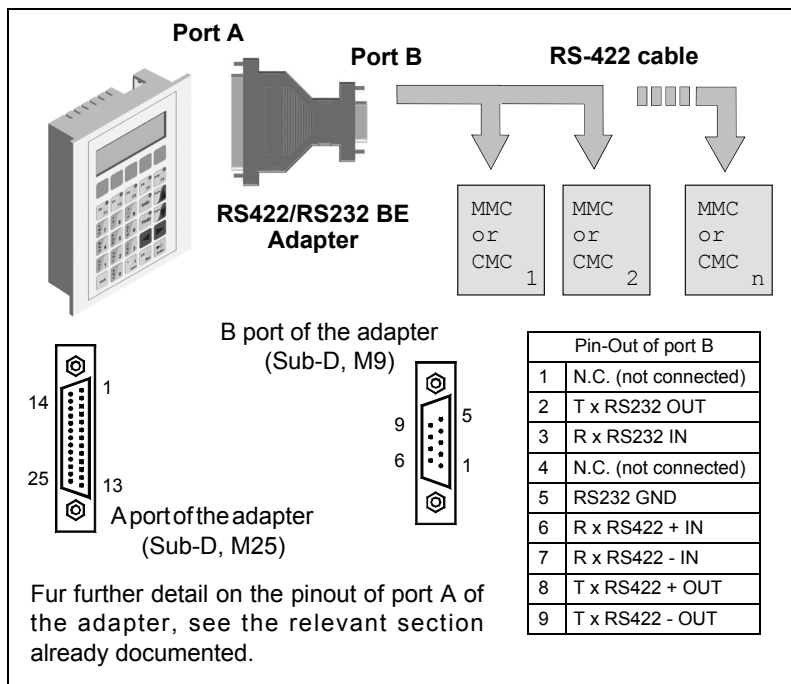

**7.**

**CABLES**  
RS-422 serial line

**F. H7/22**

RS-422 serial line connection between a VT from ESA and several MMC or CMC drives (with adapter).

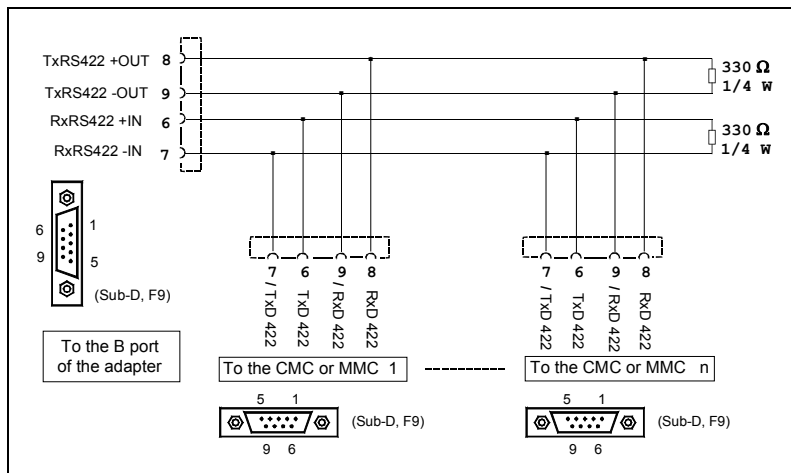

**F. H7/23**

RS-422 serial line cable between port B of the adapter and several MMC or CMC drives. Port A of the adapter must be connected to the MSP port of the VT panel from ESA.



**DDS  
HARDWARE**

Ref.1310



This chapter defines the installation process that only covers the DDS servo drive system itself.

The previous chapter already described how to connect the DDS system to the power lines.



**MANDATORY.** Only qualified personnel who know and understand the contents of this manual and all the other documentation related to this product and have been properly trained on this safety subject to recognize and prevent existing risks, are authorized to work with this servo system. Only qualified personnel may install, set up, repair and maintain this equipment.

## 8.1 Location

The type of considerations to bear in mind when placing the DDS servo drive system and run the cables must be:

- Environmental
- Mechanical
- Climatic
- Electrical
- Cooling

**NOTE.** It is entirely up to the installer to take care of these matters!

### Environmental considerations

It must be installed where:

- There are neither corrosive gasses nor explosives.
- The atmospheric conditions are favorable.
- It is not exposed to oils, water, hot air, high humidity, too much dust or metal particles suspended in the air.

### Mechanical considerations



**MANDATORY.** The DDS servo drive system that will usually include the safety controller is identified as a fixed installation meant to always work inside an electrical cabinet (enclosure) whose protection degree is IP 54 or greater. Note that the start button, the E-stop button and other elements may be installed outside the electrical cabinet (enclosure). The units must be installed vertically. Only maintenance personnel may access the electrical cabinet.

To secure the modules, use the holes and slots made for that purpose.

Vibrations should be avoided. If necessary use securing means made of a material which absorbs or minimizes vibrations.

**8.**  
**INSTALLATION** Location



**MANDATORY.** When integrating the unit into the electrical cabinet, make sure to leave a gap of at least 10 cm (3.93 inches) between it and the top, bottom and front panel of the cabinet or any other obstacle that obstructs air flow for easier heat evacuation.

For further detail, see next figure:

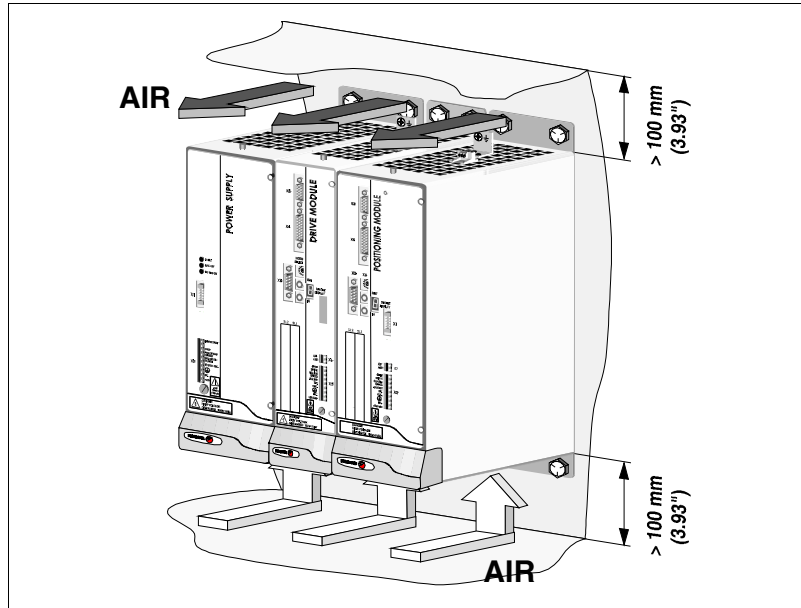

**F. H8/1**

Top and bottom clearance when installing the DDS system for easier heat evacuation.



**MANDATORY.** Mount the modular drive of greatest power next to the power supply module and use the same criteria for the rest of the drive modules.

**Climatic considerations**

The temperature inside the electrical cabinet containing the servo drive system must not exceed 55 °C (131 °F).



**MANDATORY.** Never install the DDS system next to a heat source.

The modules generate heat and when trying to decide whether the electrical cabinet containing the DDS system needs external cooling or not, one must know the power dissipated by each one of its modules.

See next table to know the power dissipated by each one of them.

**T. H8/1** Power dissipated by the modules of the DDS system.

Power supply module	Power dissipated at max. load.
PS-65A	275 W
PS-25B4	180 W
XPS-25	180 W
XPS-65	350 W
RPS-80	1 000 W
RPS-75	1 000 W
RPS-45	700 W
RPS-20	500 W



DDS  
HARDWARE

Ref.1310

Auxiliary modules	Dissipated power
APS-24	60 W
CM 1.60	0 W
ER+TH-x/x and ER+TH-18/x+FAN	It depends on the activation frequency of the Ballast protection circuit.
MAINS FILTER 42A	19 W
MAINS FILTER 130A	40 W
MAINS FILTER 180A	61 W

Modular drives	Power dissipated at 4/8 kHz
AXD/MMC 1.08	33/44 W
AXD/MMC 1.15	69/89 W
AXD/MMC 1.25	88/132 W
AXD/MMC 1.35	156/195 W
AXD/MMC 2.50	225/305 W
AXD/MMC 2.75	270/389 W
AXD/MMC 3.100	351/510 W
AXD/MMC 3.150	536/605 W
MMC 3.200	834/840 W
SPD 1.15	98/98 W
SPD 1.25	110/130 W
SPD 1.35	195/201 W
SPD 2.50	349/350 W
SPD 2.75	289/333 W
SPD 2.85	432/438 W
SPD 3100	496/546 W
SPD 3150	626/668 W
SPD 3200	1163/1187 W
SPD 3250	1333/1344 W

Compact drives	Power dissipated at 4/8 kHz
ACD/CMC 1.08	40/50 W
ACD/CMC 1.15	87/118 W
ACD/CMC 1.25	110/139 W
ACD/CMC 2.35	160/206 W
ACD/CMC 2.50	220/295 W
SCD 1.15	123/123 W
SCD 1.25	150/150 W
SCD 2.35	215/220 W
SCD 2.50	275/315 W
SCD 2.75	289/333 W



**INSTALLATION**  
 Location



**DDS  
HARDWARE**

**Ref.1310**

**Electrical considerations**



**MANDATORY.** The electrical installation my comply with standard EN 60204-1.

**Indications regarding EMC**

Electromagnetic compatibility is covered by the following standards:

**T. H8/2** Standards regarding electromagnetic compatibility.

EN 61800-3:2004 *	Adjustable speed electrical power drive systems-Part 3: EMC requirements and specific test methods.
EN 61326-3-1:2008	Electrical equipment for measurement, control and laboratory use - EMC requirements - Part 3-1: Immunity requirements for equipment performing or intended to perform safety related functions (functional safety) - General industrial applications.



\* **MANDATORY.** The installation that includes this servo system may need a harmonic suppressing filter to comply with the standard EN 61800-3:2004 which is harmonized with the EMC Directive. Otherwise, when applying solutions to limit the harmonics in each servo system included in the installation (except in systems with RPS, that would not require them) could be an expensive solution and/or would not make any technical sense. It is better to apply a global solution.



**MANDATORY.** The EMC directive defines equipment as any device or fixed installation. This device is identified as a fixed installation and is meant to work inside an electrical cabinet according to category C3 and meeting the EN 61800-3 standard.



**MANDATORY.** These **Power Drive Systems** are not meant to be used in a low voltage public mains that supplies energy to house installations. Radio frequency disturbances may be expected when used in this case.



DDS  
 HARDWARE

Ref.1310

**EMC instructions for equipment installation****MANDATORY.**

- Use galvanized or chromed plates in the installation.
- Make the connections with wide contact surfaces for the metal parts.
- Remove the paint from contact surfaces.
- Try to increase conductivity on two-dimensional contacts.
- Install a protection circuit if there is a risk of over-voltage.
- Run the motor power cable at least 20 cm away from the signal cable or use shields both on the motor cable and on the signal cable.
- Do not run the field bus cables and signal cables together in the same conduit as the DC and AC lines with a voltage higher than 60 V. The field bus cables, the signal lines and the analog lines must be run in the same conduit. **RECOMMENDATION.** Separate the conduits where the cables are running at least 20 cm and make them as short as possible. Do not install unnecessary cable loops and use short cables from the central ground point for connecting to a ground point outside the electrical cabinet.
- Avoid induction loops by choosing common routes for power, signal and data circuit cables.
- Use shielded cables for power supply and motor.
- On shielded cables, the unshielded portion of the cable used to connect them to the connectors must be as short as possible in order to reduce radiated emissions.
- The motor encoder cable must have double-shield. Although the system meets the current regulation regarding immunity using single-shielded cable, the results are better when using double-shielded cables.

**8.****INSTALLATION**  
Location**FAGOR** **DDS  
HARDWARE****Ref.1310**

Use equipotential wires in systems with:

**MANDATORY.**

- Wide-area installation.
- Different voltage sources.
- Mains through several buildings reducing the current in the cable shield and the emissions. Connect to ground the electrical cabinet, the door, the mounting plate, with ground straps or cables with a cross section larger than 10 mm<sup>2</sup> (6 AWG).
- The ground shields of the digital signal wires must be connected at both ends to a large surface or through a conductive housing of the connector. This reduces disturbances that affect the signal cables and also the emissions.
- The ground shields of the analog signal wires must be connected directly to the device (signal input), reducing the ground loops due to low frequency disturbances.
- When a unit does not have a ground connection, the shield must be connected on the side of the unit connected to ground.
- To connect large cable shield surfaces, use cable and ground clamps.
- Run a single shielded cable, in one piece, without joints. If a cable must necessary be cut for the installation, connect it with the shield connections and through a metal cover at the cut (joint) point. In the worst case, if it is not possible to use shielded connectors, keep a minimum length of cable exposed to disturbances guaranteeing a good connection between the shields. See figure **F. H8/2.A**.
- Mount switching devices such as contactors, relays or electro-valves with interference suppression elements or arc suppressors (e.g. diodes, varistors, RC circuits).
- Install power and control components separately.
- Install before mains and the servo drive system mains chokes to reduce harmonics and expand the useful life of the product. EMC limit values may be improved by also using external filters.
- Use equipotential cables when having long lines to reduce the current through the cable shield.
- When connecting power cables, the shield of this cable should be connected to a ground bar. See figure **F. H8/2.B**.



**8.**  
**INSTALLATION**  
Location

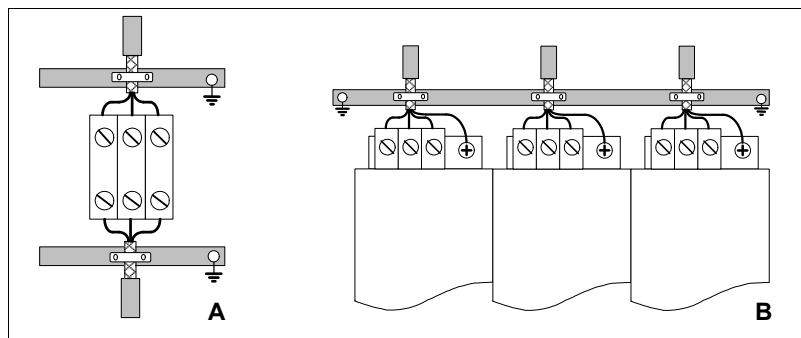

**F. H8/2**

**A.** Make the shielded cables as short as possible when the connectors are not shielded. **B.** Connection of the power cable shield to a bar that is connected to ground.



DDS  
HARDWARE

Ref.1310

See example of electrical installation in the next figures.

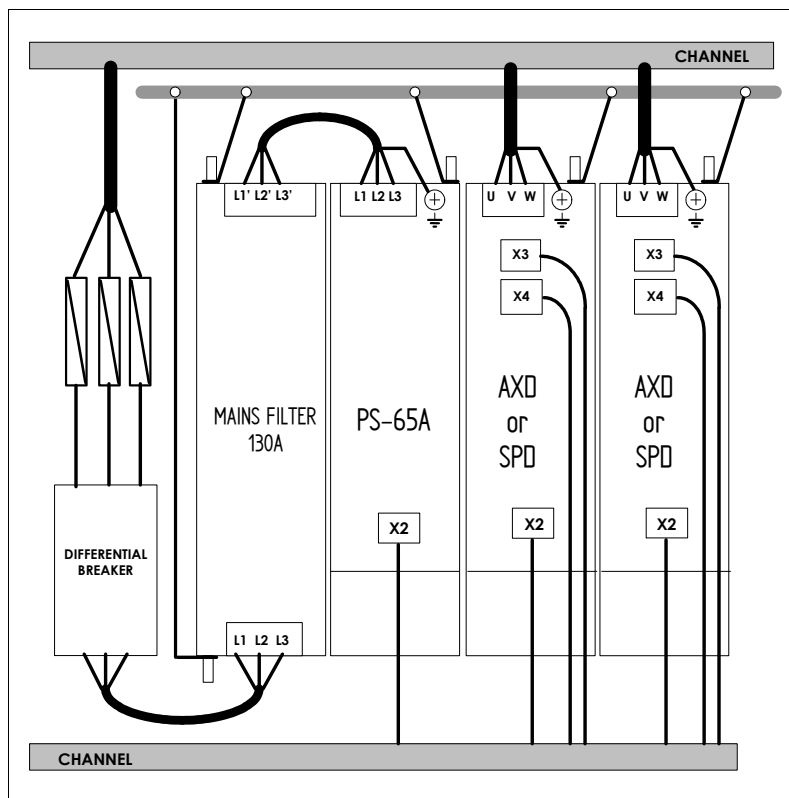

**F. H8/3**

Cables for connecting the DDS system with a PS-65A power supply.

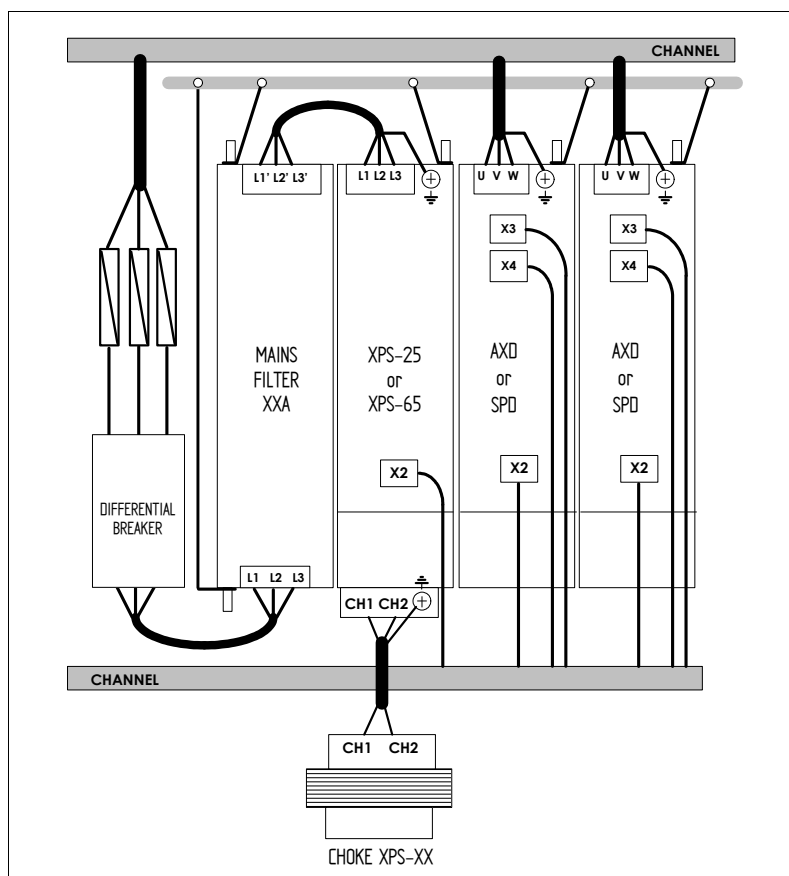

**F. H8/4**

Cables for connecting the elements of the DDS system with an XPS power supply.

**8.**  
INSTALLATION  
Location



DDS  
HARDWARE

Ref.1310

**8.**  
**INSTALLATION**  
Location

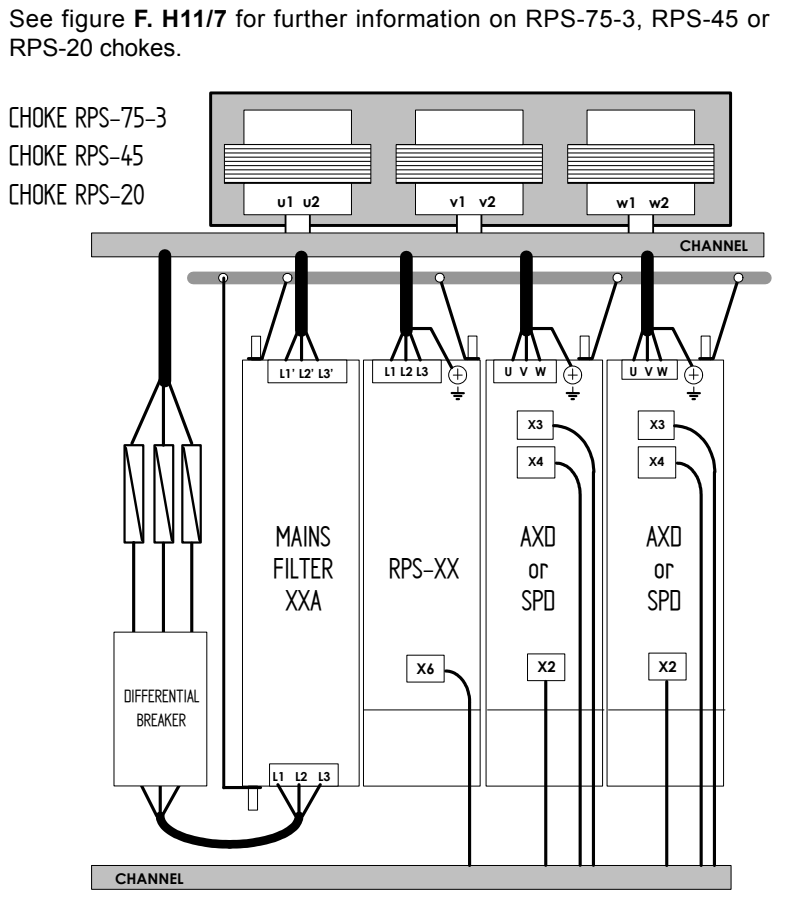

**F. H8/5**

Cables for connecting the DDS system with an RPS power supply.

**Ventilation related considerations**



**MANDATORY.** The ventilation for the electrical cabinet must be enough to dissipate the heat generated by all the devices and components working inside.

The following should be used to cool the electrical cabinet:

- **Heat exchangers:** They prevent contaminated air (mist, metallic dust in suspension, etc.) from getting into the electrical cabinet hence eliminating the chances of accumulating particles, condensation, etc. in the cooling circuits of the DDS system modules.

If it is impossible to use heat exchangers, then:

- **Air extraction system:** They prevent the air from entering the electrical cabinet with a fan.



DDS  
HARDWARE

Ref.1310

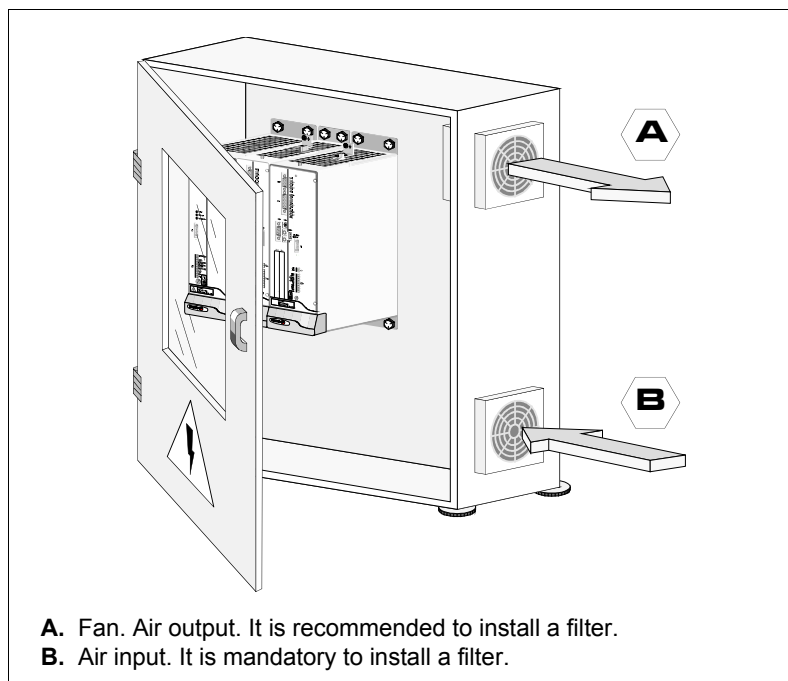

#### F. H8/6

Location of the air intake and output in the electrical cabinet

- Place the extractor fan at the top of the cabinet and the air intake at the bottom. See previous figure.
- To have a filter in the air input. The fan should also have a filter.
- Decrease the air intake speed from the outside by making the air input window larger than that of the fan. The required power and air flow depends on the power installed.
- Install the DDS system as far away as possible from air inputs and outputs.
- Carry out periodic maintenance on air filters.

Use the following suggestions to minimize the maintenance of this type of cooling systems and the contamination of the electrical cabinet:

- Set the fan to work only when the inside temperature of the electrical cabinet exceeds the predetermined limit (for example 45 °C). This will decrease its running time and the flow of the incoming air while increasing the lifespan of the fan. The cost of this solution is minimal using a bi-metal type thermostat or controlling it by using one of the outputs of the PLC or CNC.

Install a fan whose speed varies depending on the air temperature. This type of fans have an NTC sensor either integrated into it or supplied as an accessory by the fan manufacturer.

## 8.2 Inductive components

Installing the DDS system requires certain precautions regarding the connection of the inductive components such as contactors, relays, electrovalves, motor brakes or, in general, any type of coil.

Hence:

- All inductive circuits or components must have their own interference suppressor that must be installed as close as possible to the inductive component.
- The mentioned interference suppressors will be RC circuits, varystors or suppressor diodes.



**MANDATORY.** Do **not** use **fly diodes** as interference suppression elements for inductive components. These diodes can only serve as interference suppressor of the inductance due to the cabling itself.

- The excitation cables of the inductive components and the signal cables must not run in the same channel especially when not using shielded cables for these signals. A typical scenario is when using inductive proximity switches or similar usually connected with an unshielded cable.
- In extreme situations and if the sensors used on the machine are very sensitive to the interference conducted through the supply cables (24 V DC), it may be necessary to isolate or decouple them from that of the supply of the system elements (inductive components, drives, etc.).

8.

**INSTALLATION**  
 Inductive components



DDS  
HARDWARE

Ref.1310

## 8.3 System installation

### Preparation

After knowing the system's environment, the step before installing the DDS system is the following:

- Preparing the mounting fixtures inside the electrical cabinet. See chapter 11. **DIMENSIONS**, that shows all the necessary values.
- Unpack motors, drive modules, auxiliary modules and other elements that make up the DDS system.
- Mount each of the motors on the machine.
- Install all the modules making up the servo drive system in the electrical cabinet.

### Procedure

Follow these steps for a complete system installation:

- Mount all the system modules in the electrical cabinet.
- Mount the mains filter.
- Connect electrically and mechanically all the modules with each other.
  1. Connect the plates on the power bus located at the bottom of each module (under the cover).



**DANGER. Remember that an auxiliary power supply is already integrated into the XPS and RPS power supplies. If it is necessary to also install an APS-24 auxiliary power supply module for any reason together with one of these power supplies, NEVER connect APS-24 modules whose reference is PF 23A or older. With newer references, you may connect the APS-24 module to the power DC bus of the DDS system regardless of the main power supply it may come with.**

2. Connect the ground bars at the top and make the connection next to the ground terminal.
  3. Connect the internal bus.
  4. Connect the external Ballast resistor accordingly. See the section “heat dissipation” in this chapter.
- Connection with motors and the CNC.
    1. Cable from mains to the drive system through the filter.
    2. Power cable from each motor to each drive.
    3. Feedback cable from each motor to each drive.
    4. Circuit for the control of the brake (if applicable).
    5. Power for the 24 V DC auxiliary power supply from mains (APS-24, PS-25B4, XPS or RPS).
    6. Power the control circuits of each drive module with 24 V DC.
  - Control and communications signals.
    1. Encoder simulator cable from each drive to the CNC (if applicable).
    2. Analog velocity command voltages from the CNC to each drive. See the section “analog command” in this chapter.
    3. Connection of the control signals of the modules, inputs and outputs.
    4. SERCOS ring or CAN bus connection accordingly. See the section “SERCOS connection” or “CAN connection” in this chapter.
    5. Identify each system drive with its rotary switch.
    6. Module connection with the CNC through a fiber optic ring (SERCOS) or cable (CAN) accordingly. See the section “SERCOS connection” or “CAN connection” in this chapter.
    7. Module connection with an ESA panel via RS-422 if applicable. See the section “RS-422 serial line connection” in this chapter.

8.

INSTALLATION  
System installation

**FAGOR** 

**DDS  
HARDWARE**

**Ref.1310**

# 8.

**INSTALLATION**  
System installation



**INFORMATION.** Remember that FAGOR provides all the cables needed for the installation. If the user chooses to make his own cable, - see chapter 7. **CABLES** - that indicates the pinout of the connectors at both ends, mechanical characteristics and other considerations.

- Adjust the modules through the RS-232 serial line using the application for PC (WinDDSSetup).



**INFORMATION.** In order for the FAGOR Servo System to meet the European Directive on Electromagnetic Compatibility 2004/108/EC, the modules installation rules must be strictly followed regarding:

- Installation of the “MAINS FILTER □A”.
- Electrical installation of the power stage: wiring to mains and motor-drive power connection.

### Electrical precautions



**WARNING.** The system must always be installed before applying voltage according to the EN 60204-1 standard. Ignoring it may cause serious injuries, even death.

Once the installation is completed and before doing anything with the servo drive system:



**WARNING.**

- Always disconnect all power supplies, including the external power that feeds the control board that could be present.
- Wait at least 4 minutes until the capacitors of the DC bus are fully discharged. Make sure that the DC BUS voltage is lower than 42 V DC.
- Install and close all covers and ground the drive system before applying voltage
- Turn off the mains voltage using an appropriate switch to achieve a voltage-free condition.



**MANDATORY.** The cross section of the protective ground conductor must comply with the applicable standards. Ground the cable shields at both ends; however, the shields are not protective ground conductors.



DDS  
HARDWARE

Ref.1310

## 8.4 Connection between modules

### Power bus connection

The power bus is connected through the terminals hidden under the cover at the bottom of each module. To do this, use 2 of the 3 plates and the washers and nuts supplied with each module.



**MANDATORY.** All the modules must be tightly joined to each other guaranteeing a good electrical contact.

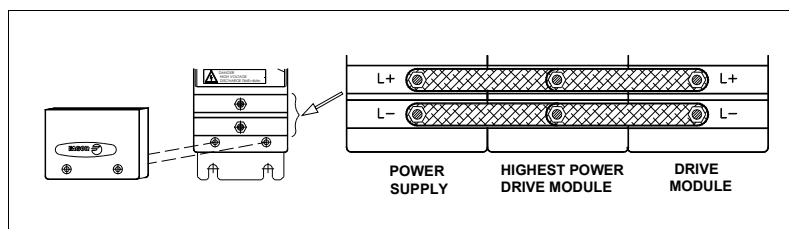

**F. H8/7**

Power bus connection.

The tightening torque must be between 2.3÷2.8 Nm.

The power supply module must provide the power needed by all the drives connected to it. If this power exceeds the maximum value that the power supply can provide, two power supplies will be required.

Assign to each of them the supply of a separate group of drives.

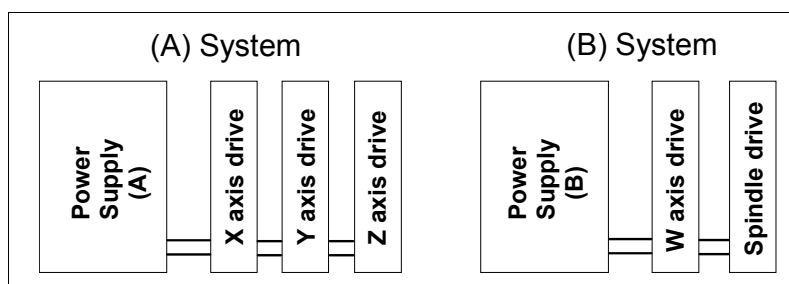

**F. H8/8**

If two power supplies are needed, they must be installed in separate groups.



**WARNING.** The power buses of different power supply modules must never be connected in parallel. Always make separate groups, connecting each power supply to a different group of drives.

8.

**INSTALLATION**  
 Connection between modules

**Joining the chassis between modules**

The chassis of the modules must be connected to each other through the terminal on top of each module. To do this, the third plate and the washers and nuts supplied with each module.

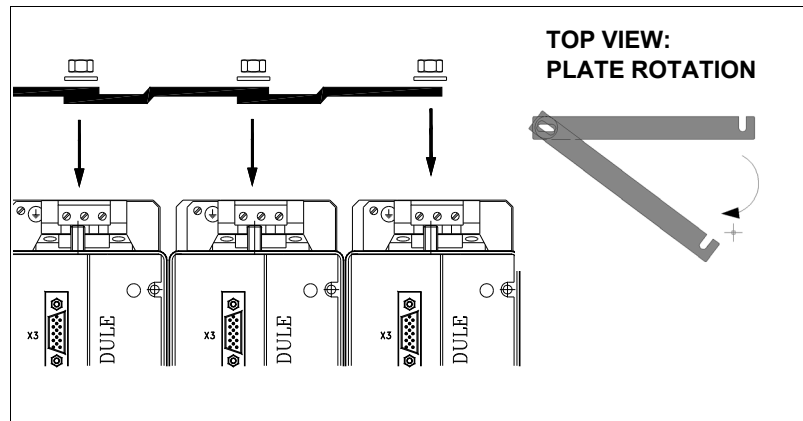

**F. H8/9**

Joining the chassis between modules.

The tightening torque must be between 2.3÷2.8 Nm.

Connecting these terminals by means of metal plates offers mechanical rigidity; but **it does not guarantee** proper ground connection of each module.

To replace a drive module in case of a failure or remove it from the DDS system for inspection, follow these steps to “free” it from the other modules.

- A.** Loosen the screw and the nut of the affected module.
- B.** Loosen the nut of the adjacent drive on each side that joins it to the affected drive.
- C.** Rotate the plate of the affected drive and that of the one to its left, see figure **F. H8/9**.

After these steps, the drive will be totally free from the rest of the drives that were joined by the plate.

All the cables connecting it to the rest of the modules must also be removed.



DDS  
HARDWARE

Ref.1310

## Ground connection



**MANDATORY.** It is up to the system integrator to meet all the requirements of local and national electrical codes as well as all the regulations applicable regarding the grounding of the whole unit.

The chassis of each modules must be connected to a single point and from there to the ground terminal of the electrical cabinet. When applying a 10 A current between this ground point and any of these points, the voltage drop must not exceed 1 V. Use the washers and nuts supplied with each module to make the ground connection.

When not having a separate ground point, join the plates to the terminal of the power supply module which, in turn, will be connected to mains ground.

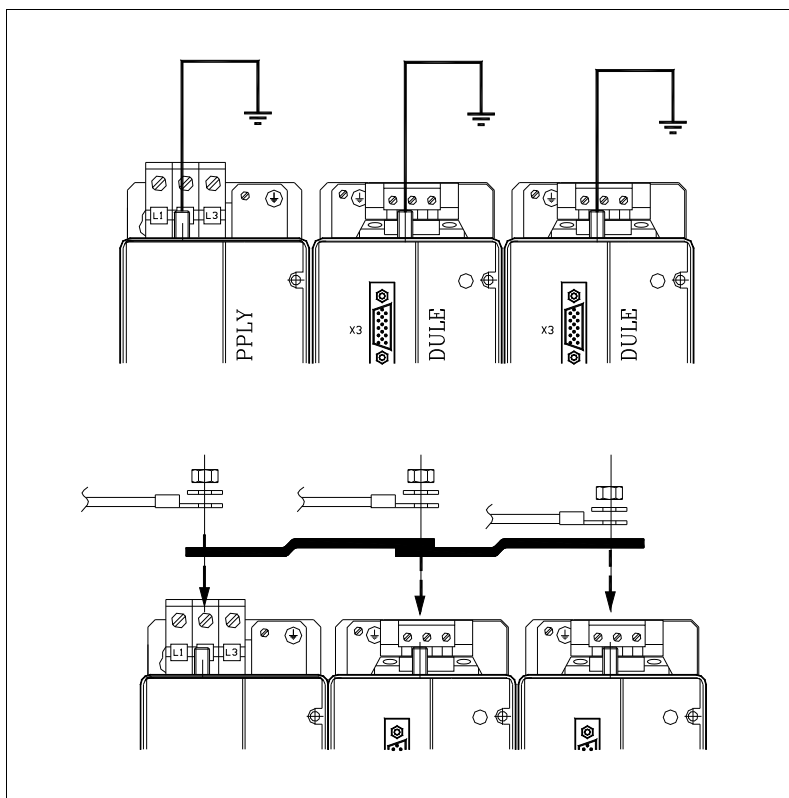

**F. H8/10**

Ground connection.

The tightening torque must be between 2.3÷2.8 Nm.



**MANDATORY.** Take a ground cable (as short as possible) from each module to each main machine ground point.



**MANDATORY.** In order to ensure compliance with the European Directive on Electromagnetic Compatibility 2004/108/EC, it is a must to:

- Verify that all the requirements of local and national electrical codes are met as well as all the regulations applicable regarding the grounding of the whole unit.
- Power the system through “MAINS FILTER □A”.
- Secure the filter onto a metallic support with a good contact on its whole base, good ground connection and as close to the power supply as possible.
- Make all the ground connections indicated in the figure **F. H8/10** with a cable having a section equal to or greater than the three-phase power supply and at least 6 mm<sup>2</sup>.
- Always use shielded cables for three-phase motor connections. See chapter **7. CABLES**.

8.

INSTALLATION  
Connection between modules

**FAGOR** 

DDS  
HARDWARE

Ref.1310

### Internal bus connection

To make this connection, join the X1 connectors of each module with the ribbon (flat) cables supplied with each of them as shown in the next figure:

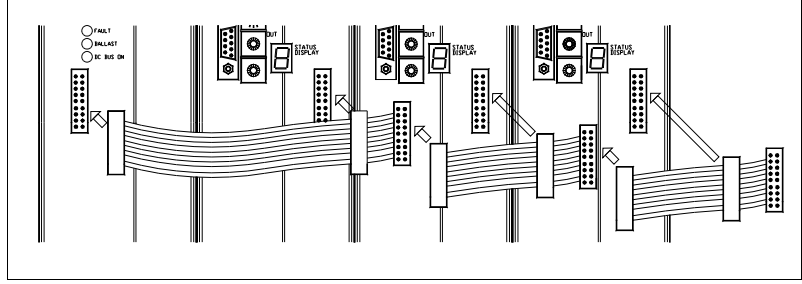

**F. H8/11**

Internal bus connection.

8.

INSTALLATION

Connection between modules



DDS  
HARDWARE

Ref.1310

### Connection to the external Ballast resistor

The external resistor modules are designed to be installed in the corresponding terminals of the power supplies or compact drive modules (with an integrated power supply) in order to dissipate the excess energy generated when braking the servomotors.

See chapter 5, the section regarding the “external Ballast resistor selection guide” to know whether it is necessary or not to install an external Ballast resistor or the internal one is enough.

See chapter 4, section “RESISTOR MODULES”, for further detail on the external Ballast resistors associated with the power supplies and with the compact drives when required to install one.

### Resistor configurations with power supply

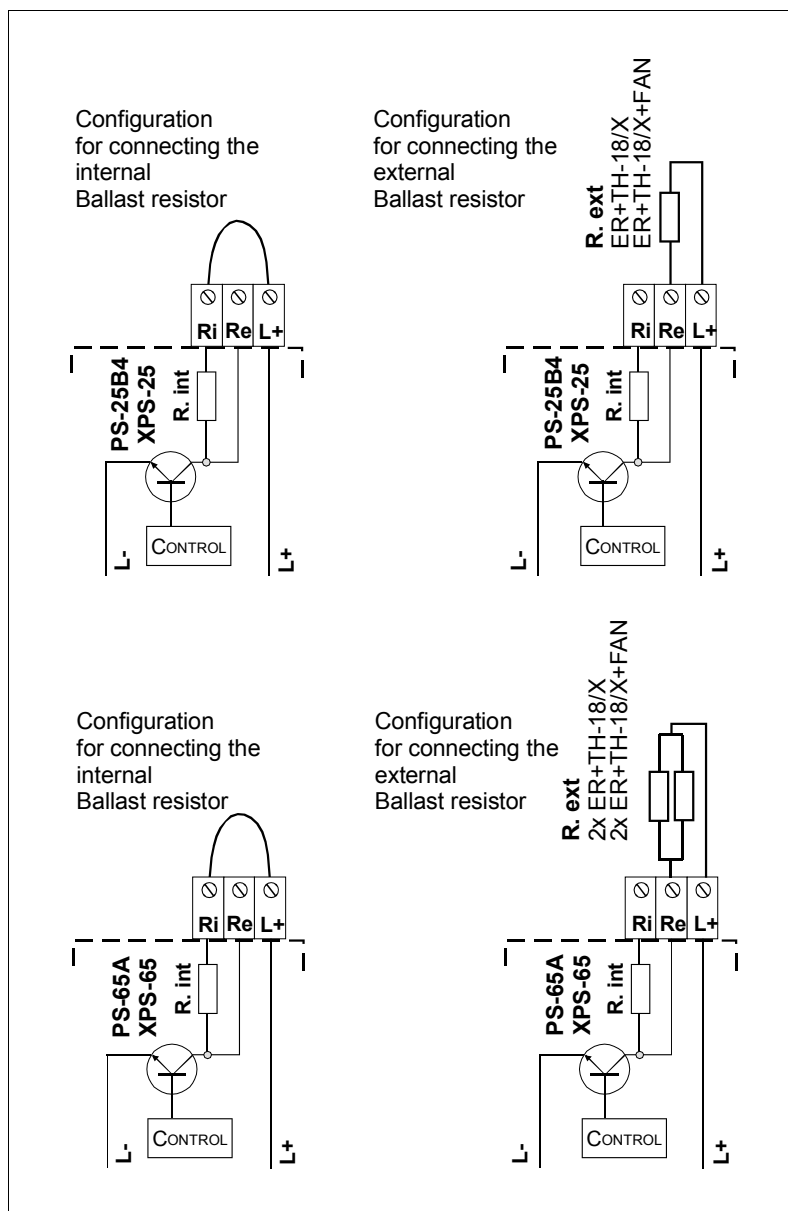

F. H8/12

Electrical configurations of the ballast resistor for power supplies.



**WARNING.** Never connect an external resistor in parallel with the internal Ballast resistor. It may cause severe damage to the system.



**INSTALLATION**  
Connection between modules



**DDS  
HARDWARE**

Ref.1310

8.

**INSTALLATION**  
Connection between modules

**Electrical configurations of the resistor with compact drives**

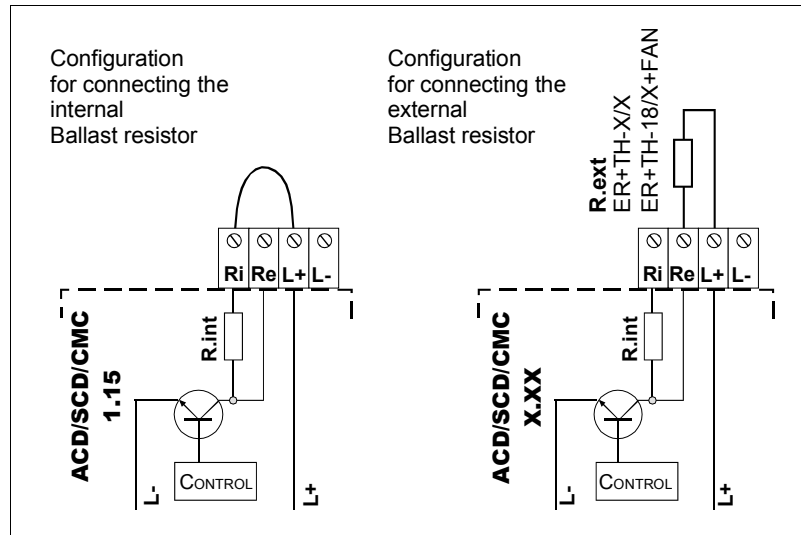

**F. H8/13**

Electrical configurations of the Ballast resistor with compact drives.



**WARNING.** Never connect an external resistor in parallel with the internal Ballast resistor. Ignoring this warning may cause severe damage to the system.

### How to install an external Ballast resistor with internal thermostat and with no fan



**WARNING.** On top of the ER+TH modules, the air temperature can reach values over 120 °C (248 °F). Therefore, the resistor should be mounted away from the rest of the modules or even outside the electrical cabinet, **always vertically** and away from cables and other temperature sensitive material.

**Always install it vertically**

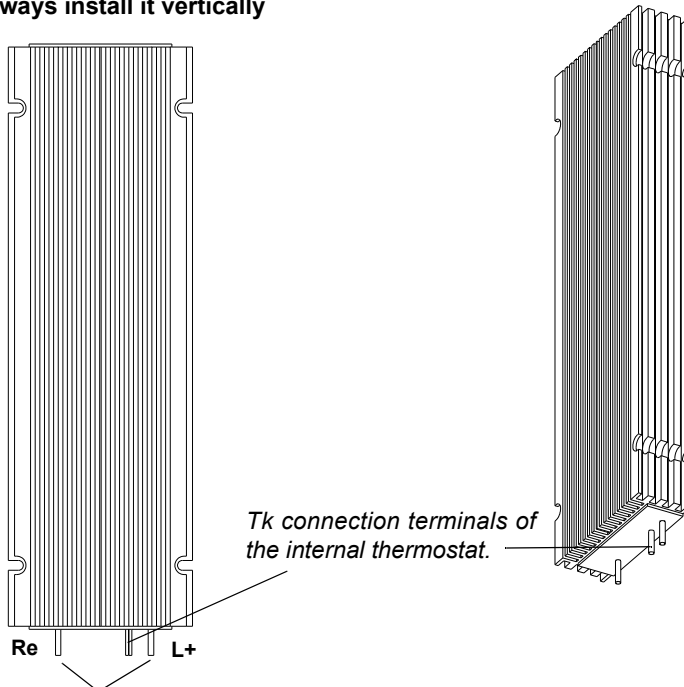

Ballast resistor connection terminals.

**Diagram**

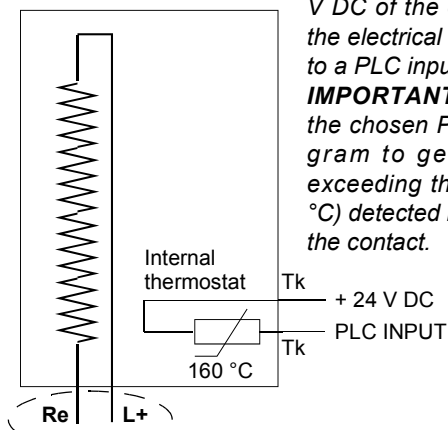

Take either one of the two pins to + 24 V DC of the external power supply of the electrical cabinet and the other one to a PLC input.

**IMPORTANT.** Remember to manage the chosen PLC input in the PLC program to generate an error when exceeding the limit temperature (160 °C) detected by the sensor and to open the contact.

Take the Ballast resistor terminals to the Re and L+ terminals of the terminal strip of the Ballast of the power supply or compact drive accordingly.

**F. H8/14**

Installing the external Ballast resistor with internal thermostat and with no fan.

8.

INSTALLATION  
Connection between modules



DDS  
HARDWARE

Ref.1310

**How to install an external Ballast resistor with an external thermostat and with no fan**



**WARNING.** On top of the ER+TH modules, the air temperature can reach values over 120 °C (248 °F). Therefore, the resistor should be mounted away from the rest of the modules or even outside the electrical cabinet, **always vertically** and away from cables and other temperature sensitive material.

**8.**

**INSTALLATION**  
Connection between modules

**Always install it vertically**

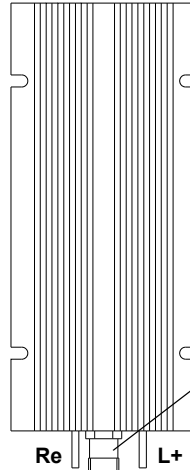

Ballast resistor connection terminals.

Element to connect with the external thermostat

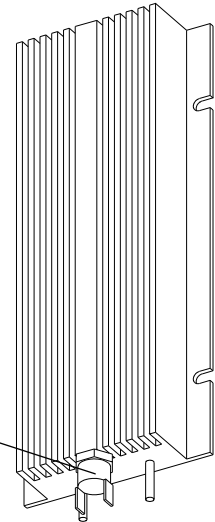

External thermostat

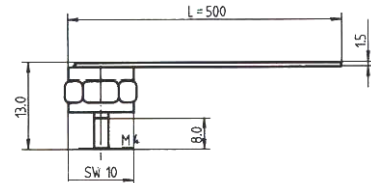

**Diagram**

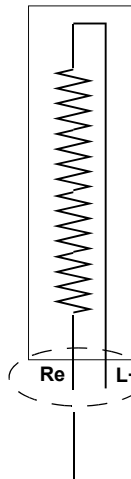

Take either one of the two pins to + 24 V DC of the external power supply of the electrical cabinet and the other one to a PLC input.

**IMPORTANT.** Remember to manage the chosen PLC input in the PLC program to generate an error when exceeding the limit temperature (160 °C) detected by the sensor and to open the contact.

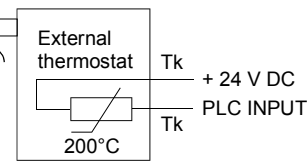

Take the Ballast resistor terminals to the Re and L+ terminals of the terminal strip of the Ballast of the power supply or compact drive accordingly.

**F. H8/15**

Installing the external Ballast resistor with internal thermostat and with no fan.



DDS  
HARDWARE

Ref.1310

### How to install an external Ballast resistor with internal thermostat and fan



**WARNING.** Therefore, the resistor should be mounted away from the rest of the modules or even outside the electrical cabinet, **always vertically** and away from cables and other temperature sensitive material.

#### Always install it vertically

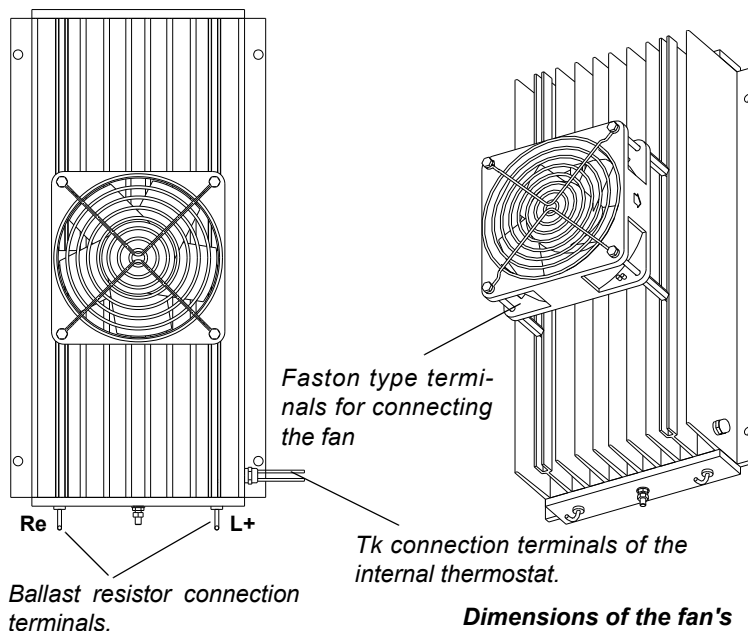

Ballast resistor connection terminals.

Tk connection terminals of the internal thermostat.

#### Dimensions of the fan's Faston terminals

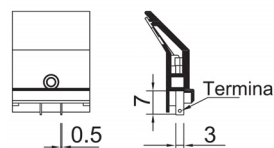

#### Diagram

Take the fan connection terminals to an outlet of the electrical cabinet, single phase 50/60 Hz, 220/240 V AC. Consumption: 0.15/0.13 A, 23/20 W.

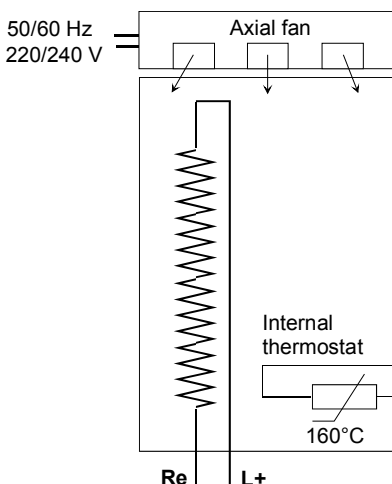

Take either one of the two pins to + 24 V DC of the external power supply of the electrical cabinet and the other one to a PLC input.

**IMPORTANT.** Remember to manage the chosen PLC input in the PLC program to generate an error when exceeding the limit temperature (160 °C) detected by the sensor and to open the contact.

Take the Ballast resistor terminals to the Re and L+ terminals of the terminal strip of the Ballast of the power supply or compact drive accordingly.

#### F. H8/16

Installing the external Ballast resistor with internal thermostat and fan.

# 8.

INSTALLATION  
Connection between modules



DDS  
HARDWARE

Ref.1310

### How to install two external Ballast resistor in parallel. Diagrams

# 8.

**INSTALLATION**  
 Connection between modules

#### Always install both resistors vertically

##### Diagram for two resistors in parallel with fan and internal thermostat

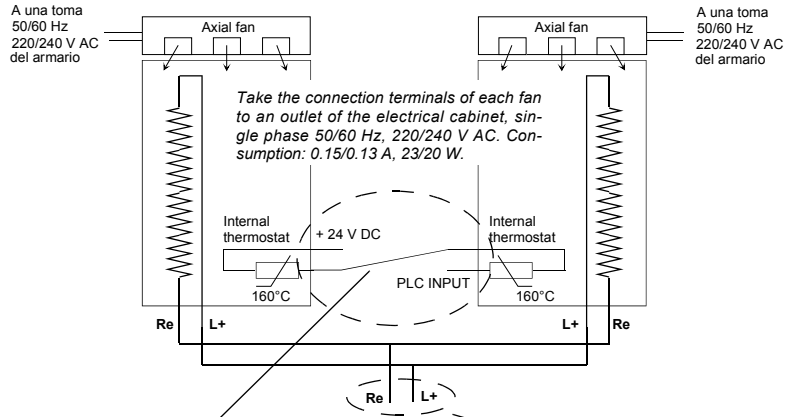

Take the terminal labeled + 24 V DC to an external 24 V DC power supply of the electrical cabinet and the other one labeled PLC INPUT to a PLC input. **Important.** Remember to manage the chosen PLC input in the PLC program to generate an error when exceeding the limit temperature (160 °C) detected by the sensor and to open the contact.

Take the indicated terminals to the Re and L+ terminals of the terminal strip of the Ballast of the power supply (only PS-65A or XPS-65).

##### Diagram for two resistors in parallel with an internal thermostat and no fan

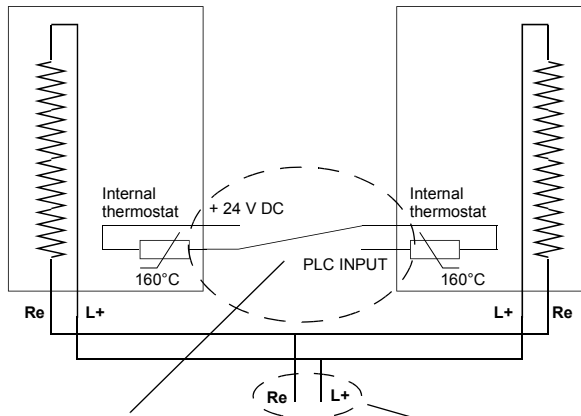

Take the terminal labeled + 24 V DC to an external 24 V DC power supply of the electrical cabinet and the other one labeled PLC INPUT to a PLC input. **Important.** Remember to manage the chosen PLC input in the PLC program to generate an error when exceeding the limit temperature (160 °C) detected by the sensor and to open the contact.

Take the indicated terminals to the Re and L+ terminals of the terminal strip of the Ballast of the power supply (only PS-65A or XPS-65).

#### F. H8/17

Installing two external Ballast resistors in parallel.



DDS  
HARDWARE

Ref.1310

## Ohm values



**WARNING.** The Ohm value of the external Ballast resistor must be the same as that of the internal resistor of that module.

See the tables in section “**RESISTOR MODULES**” of chapter 4 that show the compact drives and the possible external Ballast resistors associated with them.



**MANDATORY.** On all compact drives (except those whose reference is SCD-NR x.xx), the external resistor supplied with the units. ACD/SCD/CMC 1.08 /1.15 models are also an exception.

On compact drives “ACD/SCD/CMC 1.08/1.15”, as opposed to the rest of the compact models, do not install any external Ballast resistor. The internal one is enough, except on “SCD 1.15” models where it would be possible to install the internal resistor ER+TH-43/350 if the application so required.

In general, on compact models “ACD/CMC 1.08/1.15” the internal dissipation Ballast resistor will be enough, but if it is not in a particular situation, it is possible to install an external resistor of the same Ohm value as the internal one and greater dissipation power.

**NOTE.** Actually, the external resistor provided with the unit is considered enough for most applications. If it is not enough, install one of the same Ohm value and greater power.

On any compact drive whose reference is SCD-NR x.xx no external Ballast resistor will be supplied with the unit. The user will place the order for the external resistor required by the application with a FAGOR representative. Remember that it must have the same Ohm value as the internal resistor of the module.

8.

INSTALLATION  
Connection between modules

**FAGOR** 

**DDS  
HARDWARE**

**Ref.1310**

**8.**

**INSTALLATION**  
Connection between modules

**Heat dissipation**

The external Ballast resistors can generate a great deal of heat. That's why, sometimes, depending on the temperature of the installation area, it may be necessary to evacuate the heat by means of fans.



**INFORMATION.** If a fan is required due the conditions of the location where the resistor will be installed, remember that Fagor Automation offers external ballast resistors with fan.

See an example with data on the temperatures reached in points of the top of the module and the effect of the fan:

**T. H8/3** Temperatures reached in the points defined earlier in the figure **F. H8/18**. \*Temperature variation due to the effect of the fan (PAPST 614). Temperature in °C (conversion: °F = 32 + 1.8 °C).

Dissipated power (W)	734	896	1042	1400	1400 *
Ambient temperature (°C)	25	22	24	24	24
T1 (°C)	90	89	115	138	74
T2 (°C)	157	170	185	217	113
T3 (°C)	80	79	88	104	64
T4 (°C)	60	68	72	82	46
T5 (°C)	50	54	57	65	47
T6 (°C)	40	40	44	45	44

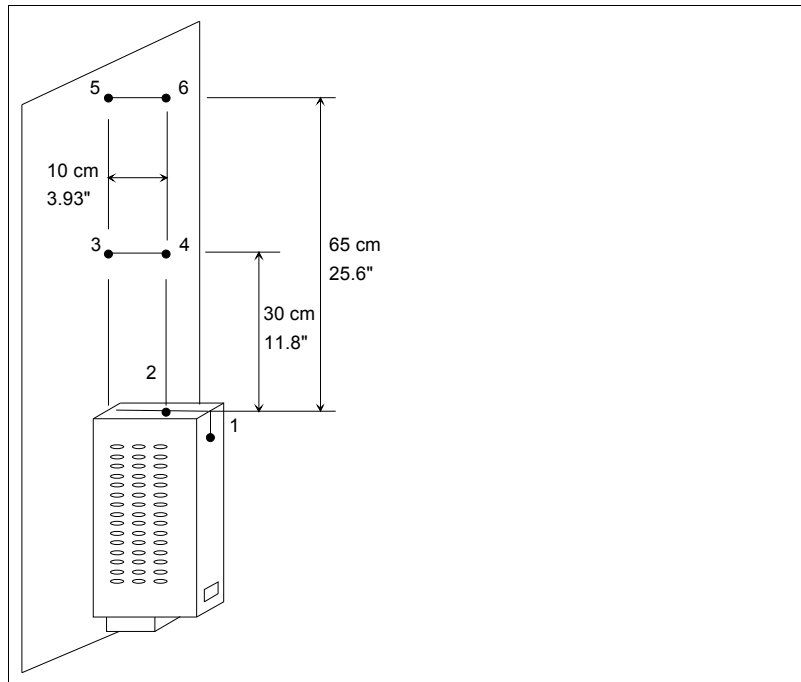

**F. H8/18**

Location of the temperature measuring points.



DDS  
HARDWARE

Ref.1310

## 8.5 Power supply connections

See chapter 6. **POWER LINE CONNECTION** of this manual for connecting the mains cable through the filter.

To connect the power cable, the motor-drive cable and the brake control circuit, see the relevant chapter in the motor installation manual.

### Power supply for the control of modules

The internal circuits of all electronic modules need 24 V DC.

The power supply module PS-65A and the modular drives need this voltage supplied through their connector X2.

These modules have stabilizing system for the supplied voltage.

The maximum consumption of each module is:

Power supply PS → 1 A

Modular drive → 2 A



**MANDATORY.** The 24 V DC voltage supply is essential for the system to run.

The auxiliary power supply APS-24 offers 24 V DC and 10 A. Regenerative power supplies XPS and RPS and non-regenerative power supplies PS-25B4 supply themselves and also output a total of 8 A of their 24 V DC. Compact drives are self-supplied and offer up to 110 mA of these 24 V DC.



**MANDATORY.** All these 24 V DC can also be used in the circuit of the electrical cabinet, but never to activate the brake of a motor. **This is an absolute must in order to comply with the CE requirement for the machine.**



**WARNING.** The 24 V DC can also be used in the circuit of the electrical cabinet, but **NEVER TO ACTIVATE THE MOTOR BRAKE!**



**WARNING.** The 24 V DC power supply output generated in the FAGOR "POWER SUPPLY MODULE" unit must only be used for the 24 V DC control input. This voltage cannot be used to connect any other kind of device of the machine nor to take this signal outside the electrical cabinet where it is generated.



**INFORMATION.** Proper performance cannot be guaranteed in all possible cases and situations, especially when connecting inductive components.

8.

INSTALLATION  
Power supply connections

**FAGOR**

**DDS  
HARDWARE**

Ref.1310

**8.**

**INSTALLATION**  
Power supply connections

**Connection of the APS-24 power supply**

Take two mains phases and ground to the input connector X1 of the auxiliary power supply APS-24. See figure:

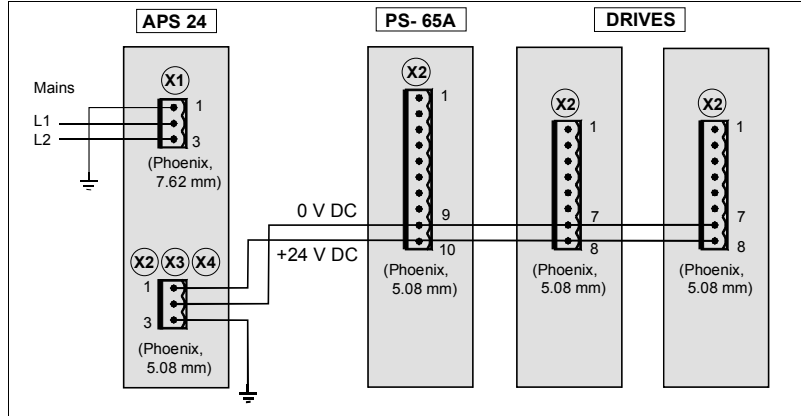

**F. H8/19**

Connection of the APS-24 with the PS-65A and the modular drives.

**Connection of the auxiliary power supply of the PS-25B4 and the XPS**

Take the two mains phases and ground to the input connector X3 of the auxiliary power supply integrated into the main power supply. See figure:

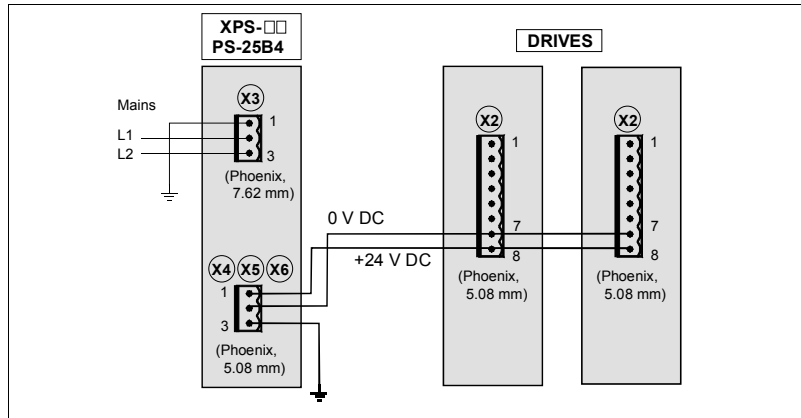

**F. H8/20**

Connection of the auxiliary power supply integrated into the PS-25B4 and XPS with the modular drives.

**Connection of the auxiliary power supply of the RPS**

Take the three mains phases and ground to the input connector X1 of the main power supply. See figure:

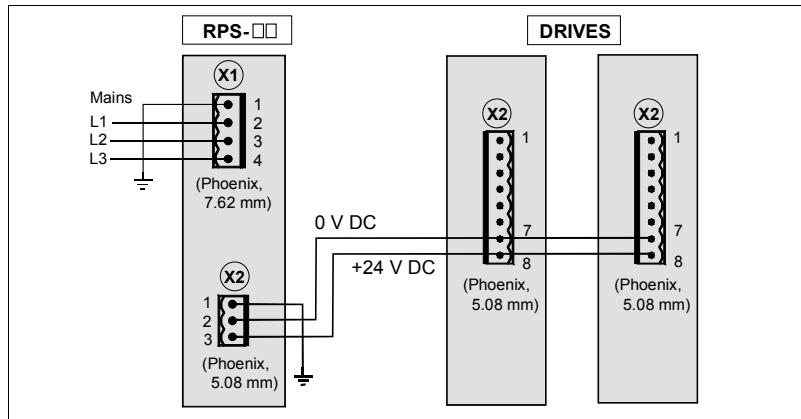

**F. H8/21**

Connection of the auxiliary power supply integrated into the RPS with the modular drives.



**DDS  
HARDWARE**

Ref.1310

## 8.6 Connection of the control and communications signals

### Motor feedback connection

The motor feedback device is an encoder.

The connection is made between the motor feedback connector and connector (X4) of the drive module. For further detail on the cables supplied by FAGOR for connecting the motor feedback, see chapter 7. **CABLES**. The technical data for the motor feedback device connector is shown in the corresponding motor manual.

### Direct feedback connection

The direct feedback device may be a linear encoder (incremental or absolute) or an external rotary encoder.

The connection is made between the connector of the linear encoder or external encoder and connector (X3) of the drive module. For further detail on the cables supplied by FAGOR for connecting the direct feedback, see chapter 7. **CABLES**.

### Encoder simulator connection

Depending on motor feedback, the drive can generate a set of signals that simulate those of a TTL encoder attached to the rotor of the motor.

The encoder simulator board of the drive module is connected to the CNC through the connector X3 of each drive (see its front panel) and connectors X1, X2, X3 or X4 of the 8055 CNC. For an 8055i CNC, the connectors will be X10, X11, X12 and X13.

For further detail on CNC connection, see the corresponding CNC manual.

See chapter 7. **CABLES** for further detail on the cables supplied by FAGOR for this connection.

### Connection for the reception of the analog command

Connector X7 of the drive has two analog input to receive the analog velocity command sent out from connector X8 of the 8055 CNC. Connector X7 offers  $\pm 15$  V DC to easily generate the velocity command with a potentiometer. An internal parameter of the drive selects the input that the servo system attends to.

See parameter IP1 in chapter 13 of the “dds-software” manual.

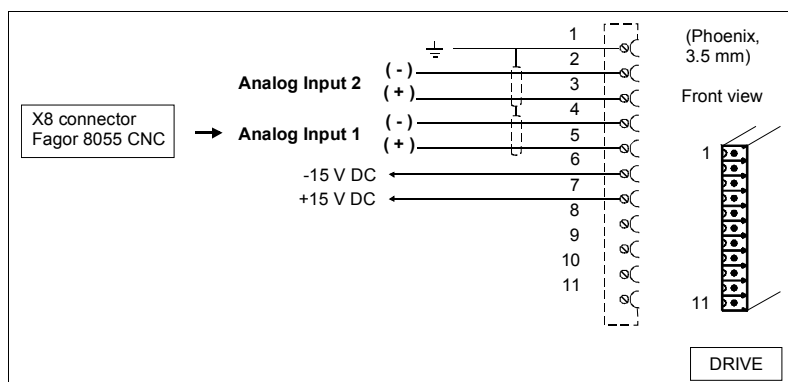

#### F. H8/22

Analog velocity command inputs.

8.

INSTALLATION  
Connection of the control and communications signals



DDS  
HARDWARE

Ref.1310

8.

INSTALLATION

Connection of the control and communications signals

**Connection for the digital outputs**

When the drive outputs are connected to inductive loads, we must protect the optocoupler with circuits such as the ones shown in the next figure:

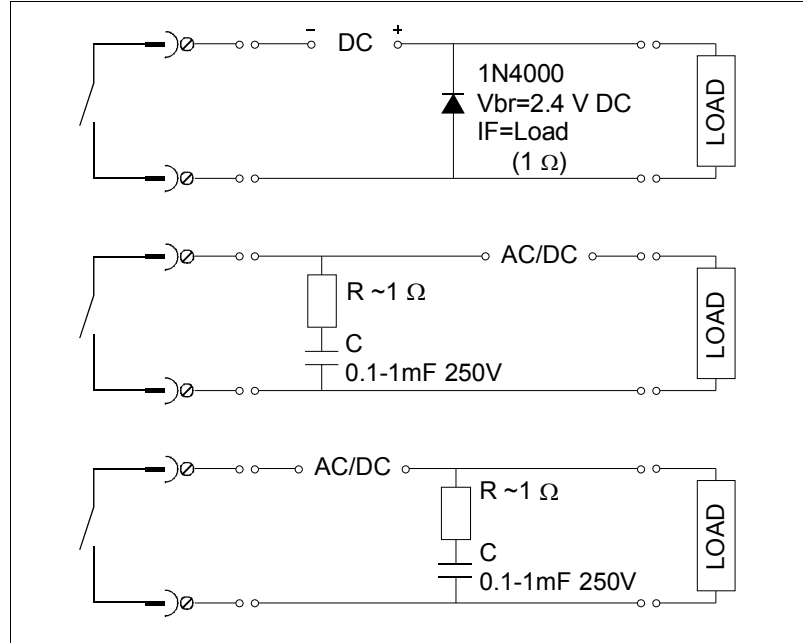

**F. H8/23**

Protection circuits for the opto-coupler of the digital output with inductive loads.

## SERCOS ring connection

The SERCOS IEC 1491 interface is an international standard for digital communications between CNC's and servo drives of CNC machines.

The SERCOS communication ring integrates several functions:

- It carries the velocity command from the CNC to the drive in digital format with greater accuracy and immunity against outside disturbances.
- It carries the feedback signal from the drive to the CNC.
- It communicates the errors and manages the basic control signals of the drive (enables).
- It allows setting, monitoring and diagnosis of the parameters from the CNC with simple and standard procedures.

All this drastically reduces the hardware required at the drive, hence, making it more reliable.

Its open standard structure provides compatibility between CNC's and servo systems from different manufacturers on the same machine.

The different drive modules and the CNC are connected through SERCOS connector X6 carried by each drive of the FAGOR catalog (see their front panel) through optic fiber. See chapter 7. **CABLES** of this manual

It is a ring connection where the 16-position rotary switch (0-15) of each drive permits selecting the address of each module integrated in it.

### Particular

Differentiate each drive with the 16-position rotary switch "NODE SELECT" with sequential numbers starting from 1.

**NOTE.** The module must be reset in order for any change made on the rotary switch to be effective.



**INFORMATION.** The DRIBUSID parameters of the CNC must have the same ID numbers as the ones assigned by means of the Node\_Select switch. See figure F. H8/24.

If the same motor is to be used as C axis and spindle, the two CNC tables must have the same value for the DRIBUSID parameter.

**If the zero identifier is assigned to a drive, that module will be ignored,** even when the ring stays closed for all purposes for the rest of the drives. That drive may receive an analog velocity command and be adjusted through the serial line.

### Example.

For example, a machine has four servo drives identified as 1, 2, 3 and 4. To ignore the second one, another one must be renamed so they are consecutive. The easiest solution for a situation like this will be 1, 0, 3 and 2.

**NOTE.** Remember that the DRIBUSID parameters of the CNC can also be modified the same way.

If the drive is going to be identified in the SERCOS ring with a number higher than 15, this value cannot be selected using the rotary "NODE SELECT" switch because it only has 15 positions. Identifying axes in the ring with addresses higher than 15 requires setting QP13. See this parameter in chapter 13 of the "dds-software" manual.

### Example.

How to identify an axis addressed in position 24 in the system SERCOS ring? When the identifier of the axis in the ring is higher than 15 (like in this case), QP13 must be set so it meets the ratio:

$$\text{Defined ID} = \text{ID to be selected at the rotary switch} + (15 \times \text{QP13}).$$

Hence, for **defined ID = 24**, select the A position at the drive's rotary "NODE SELECT" switch (same as 9) and set QP13=1.

# 8.

**INSTALLATION**  
Connection of the control and communications signals

## Interconnection

Connect in the SERCOS ring all the drives that will be governed by the CNC.

- With each fiber optic line, connect the OUT terminal of the first drive with the IN terminal of the next adjacent drive.
- Repeat this procedure with the second drive and so on up to the last drive.
- Connect the OUT terminal of the last drive with the IN terminal of the CNC.
- Connect the IN terminal of the first drive with the OUT terminal of the CNC.

When all these connections have been made, the ring will be closed. See figure F. H8/24.

**NOTE.** With each drive, FAGOR supplies a fiber optic line to connect it to its adjacent module and, upon request, the rest of the required optical fiber. See chapter 7. **CABLES.**

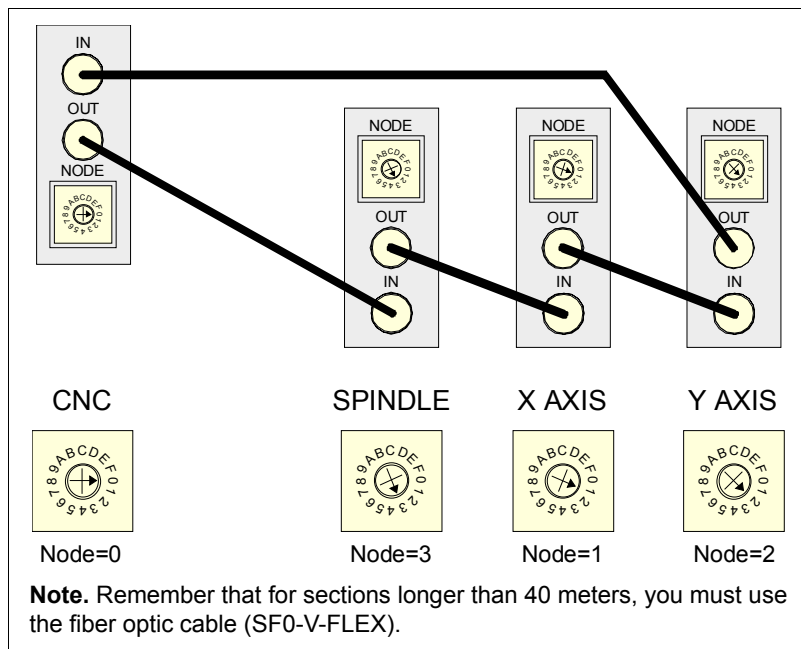

**F. H8/24**

General connection diagram for the SERCOS ring between the CNC and the drives.

**NOTE.** Note that if the machine has two separate servo drive system (each with its own power supply) and a single CNC, the same ring must interconnect all the drives of the machine.



**WARNING.** The bending radius of fiber optic cables SF0 and SF0-FLEX must always be more than 30 mm. For SF0-V-FLEX cables, this radius must be more than 60 mm.

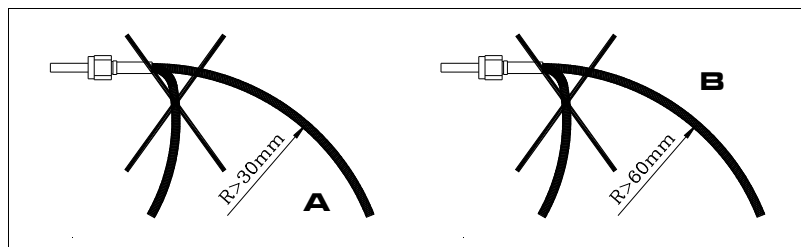

**F. H8/25**

Minimum bending radius. **A.** Fiber optic cables SF0 and SF0-FLEX. **B.** Fiber optic cable SF0-V-FLEX.



DDS  
HARDWARE

Ref.1310

### Handling fiber optic cables

FAGOR supplies the fiber optic cables with its terminals protected with a hood. Remove the terminal protecting hood before connecting any of these cables.

Either to remove the terminal protecting hood or to connect and disconnect the cable, the cable must always be held by the terminal, never pull at the cable because it could get damaged. See figure:

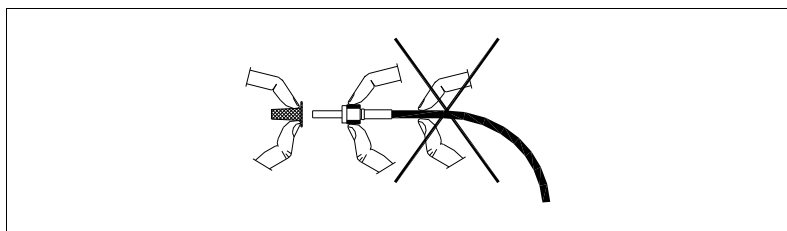

#### F. H8/26

Handling fiber optic cables.

### Transmission speed selection

From version 06.05 on, the drive may have a SERCOS board capable of transmitting data at 2, 4, 8 or 16 MBd.

**NOTE.** This board is only compatible with software version 06.05 and later. See chapter 13. **COMPATIBILITY.**

In this data transmission, each drive can receive and transmit 8 IDns (SERCOS identifiers) or 16 Words through the fast channel.

The communication speed between all the drives being governed by the CNC in the SERCOS ring is selected by hardware using the “boot” button on top of the SERCOS board connector. See figure F. H8/27.

**NOTE.** Consequently, the serial connection will no longer be necessary to select the transmission speed.

The parameter associated with the communication speed selection of the SERCOS ring is QP11 and every time a speed is selected, this parameter is associated the corresponding value.

See table T. H8/4 that shows the possible transmission speeds that will be displayed at the drive and chapter 13 of the “dds-software” manual to know the meaning of parameter QP11.

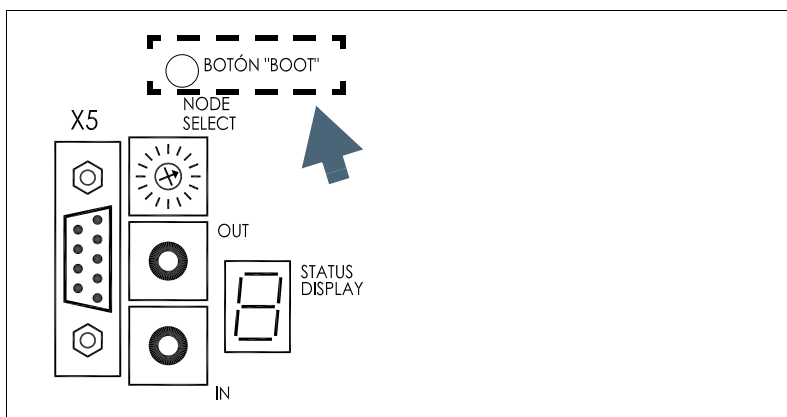

#### F. H8/27

Location of the “BOOT” button at the drive.

8.

INSTALLATION  
Connection of the control and communications signals



DDS  
HARDWARE

Ref.1310

**8.**

**INSTALLATION**  
Connection of the control and communications signals

**Transmission speed changing procedure**

In an initial state (0 state), the display shows the information that already showed in previous versions (errors, SERCOS phase, etc.). Keeping the “boot” button pressed for 3 seconds (long push) it switches to a new state (state 1) that is used for selecting the communication speed and the display shows the speed currently selected.

In this state 1, every time this button is pressed for less than 0.8 seconds (short push), the display shows the next communication speed value that may be selected.

Hence, apply several short pushes until the desired speed is displayed.

Once the display shows the desired speed, apply a long push and QP11 will be assigned its associated value that will be saved into the flash memory of the drive and will reset the drive.

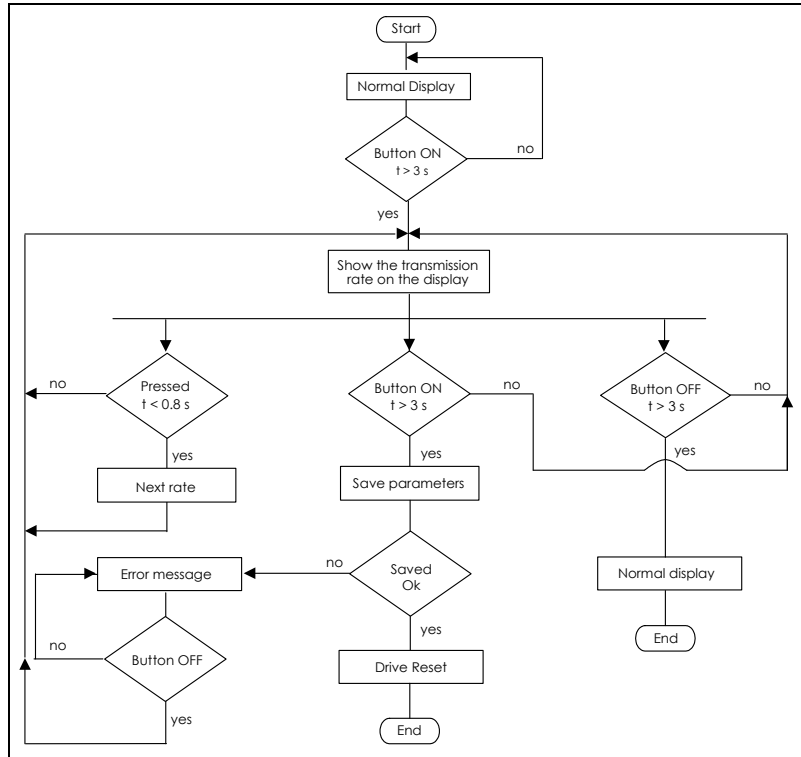

**F. H8/28**

Diagram of the SERCOS transmission speed selecting procedure.

**Anomalous events during the procedure**

Any error that comes up when saving parameters into flash memory, will be displayed with an error message on the display while the “boot” button is pressed and then it will return to state 1 (speed selection).

**NOTE.** Any attempt to select a value other than those assigned to the possible transmission speeds will generate an error and it will not be selected.

Any change of the communication speed is maintained after the drive is turned off if the command to save parameters has been previously executed successfully.

If, for any reason, the drive is turned off or reset in any stage of this procedure, when started up again, the transmission speed value given by QP11 will be the last one that was successfully assigned in previous changes.

The speed change procedure may be ignored (without making any changes) at any time if the command to save parameters has not been executed.

**NOTE.** While in state 1, after 8 seconds without pressing the “boot” button, the drive switches to 0 state and the display shows the initial information.



**DDS  
HARDWARE**

**Ref.1310**

**Values that may be assigned to the transmission speed**

The possible values, supported by the hardware, that may be selected to set the transmission speed are:

**T. H8/4** Transmission speed with SERCOS interface. Display at the drive.

Value	Speed	Shown on the display
QP11= 0*	4 MBd	4
QP11= 1*	2 MBd	2
QP11 = 2	2 MBd	2
QP11 = 4	4 MBd	4
QP11 = 8	8 MBd	8
QP11 = 16	16 MBd	16

\* to be compatible with previous versions of the SERCOS board.

See the values that will be assigned to their associated parameter QP11 in chapter 13 of the “dds-software” manual.

**8.**

**INSTALLATION**  
Connection of the control and communications signals



**DDS  
HARDWARE**

**Ref.1310**

**8.**

**INSTALLATION**  
Connection of the control and communications signals

**SERCOS connection with a FAGOR 8055 CNC**

A drive is connected to a FAGOR 8055 CNC via SERCOS through connector COM1 located on the front panel of the CPU module. See figure:

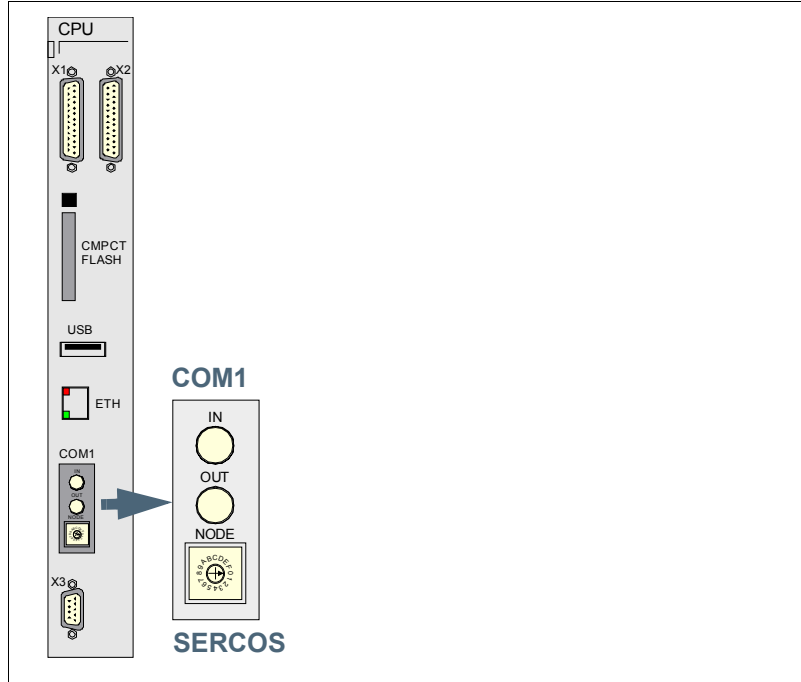

**F. H8/29**

SERCOS connector of the FAGOR 8055 CNC.

If the CNC has a CPU-turbo card, the SERCOS connection of the CNC with the drives will be made through the SERCOS module, not from the CPU module mentioned earlier. See figure:

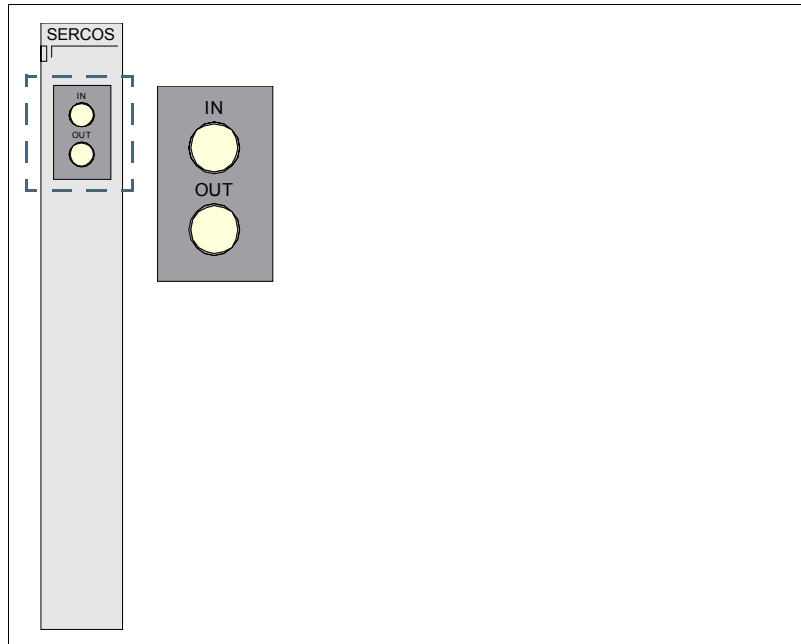

**F. H8/30**

SERCOS connector of the FAGOR 8055 CNC with CPU-turbo.

For further information, see the installation manual of the 8055 CNC.



**DDS  
HARDWARE**

**Ref.1310**

### SERCOS connection with a FAGOR 8055i CNC

The SERCOS connection of the FAGOR 8055i CNC will be made through the SERCOS DRIVES connector on the top rear of the module. See figure:

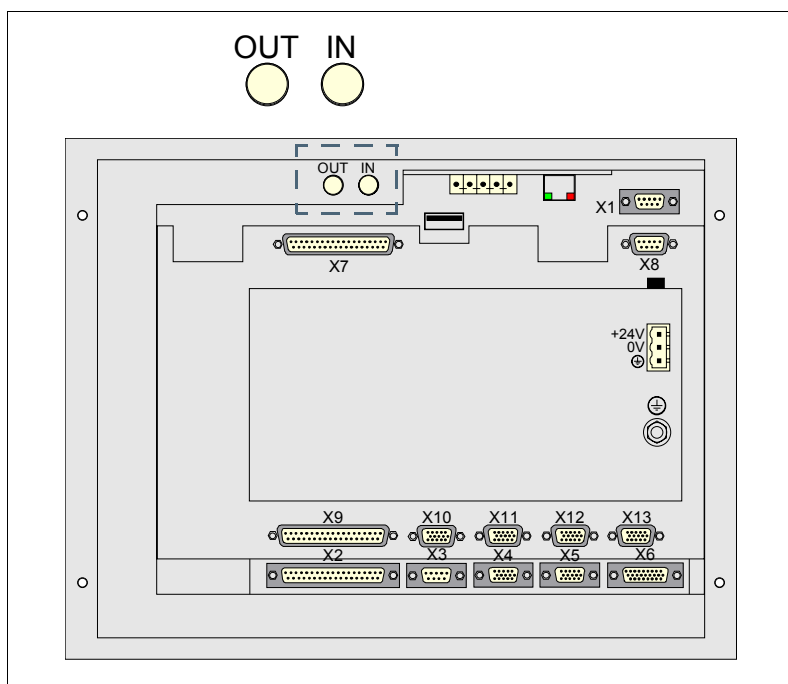

**F. H8/31**

SERCOS connector of the FAGOR 8055i CNC.

For further information, see the installation manuals of the FAGOR 8055i CNC.

### SERCOS connection with a FAGOR 8070 CNC

The FAGOR 8070 CNC is connected to the drives via SERCOS through the X2 connector located on the right side of the module. See figure:

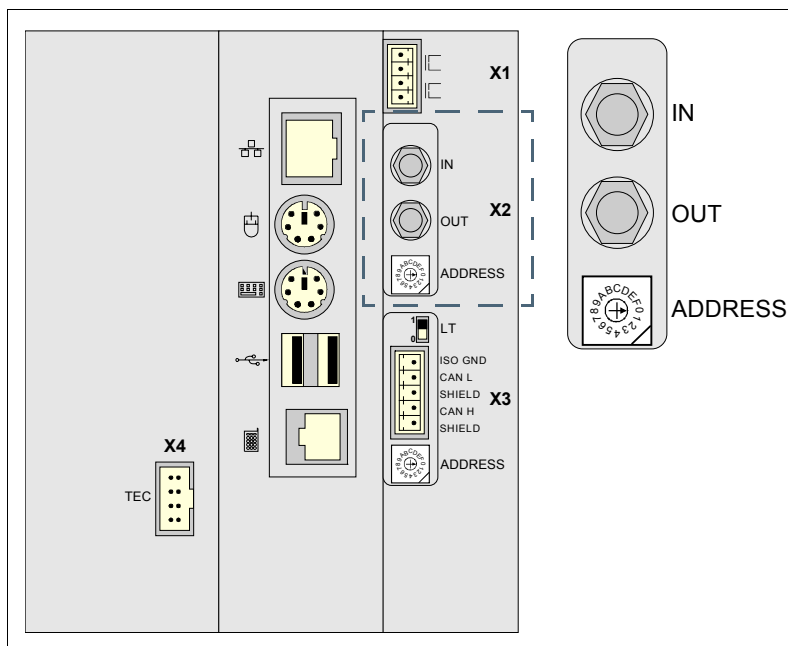

**F. H8/32**

SERCOS connector of the FAGOR 8070 CNC.

For further information, see the installation manual of the 8070 CNC.

# 8.

INSTALLATION  
Connection of the control and communications signals



DDS  
HARDWARE

Ref.1310

# 8.

## CAN bus connection

The ISO 11898 CAN interface is an international standard for digital communications between CNC's and servo drives of CNC machines. The communication protocol is CanOpen according to EN 50325-4.

The CAN communication bus integrates several functions:

- It carries the velocity command from the CNC to the drive in digital format with greater accuracy and immunity against outside disturbances.
- It carries the feedback signal from the drive to the CNC.
- It communicates the errors and manages the basic control signals of the drive (enables).
- It allows setting, monitoring and diagnosis of the parameters from the CNC with simple and standard procedures.

Its open standard structure provides compatibility between CNC's and servo systems from different manufacturers on the same machine.

The different drive modules and the CNC are connected through CAN connector (X6) carried by each drive of the FAGOR catalog (see their front panel) through the CAN cable. See chapter 7. **CABLES** in this manual .

It is a tree type connection where the 16-position rotary switch (0-15) of each drive permits selecting the address of each module integrated in it.

**NOTE.** Remember that it is not possible to use both SERCOS and CAN interfaces at the same time. The hardware can only be used with one of the two boards in the drive.

### Particular

Differentiate each drive with the 16-position rotary switch "NODE SELECT" with sequential numbers starting from 1.

**NOTE.** The module must be reset in order for any change made on the rotary switch to be effective.



**INFORMATION.** The DRIBUSID parameters of the CNC must have the same ID numbers as the ones assigned by means of the Node\_Select switch. See figure F. H8/24.

If the same motor is to be used as C axis and spindle, the two CNC tables must have the same value for the DRIBUSID parameter.

If a drive is assigned the 0 identifier, the module will be ignored.

### Example.

For example, a machine has four servo drives identified as 1, 2, 3 and 4. To ignore the second one, another one must be renamed so they are consecutive. The easiest solution for a situation like this will be 1, 0, 3 and 2.

**NOTE.** Remember that the DRIBUSID parameters of the CNC can also be modified the same way.

### Interconnection

Connect in the CAN field bus all the drives that will be governed by the CNC.

- Use the CAN cable to connect the first drive to the adjacent one (this one will then be the second drive) through their X6 connectors.
- Repeat this procedure with the second drive and so on up to the last drive.
- Use a CAN cable to connect the X6 connector of the first drive to the CAN connector of the CNC model being used.

**NOTE.** Note that the CAN cable is supplied without connectors. Before connecting it, put the cable and connectors together as indicated in figure F. H8/33.

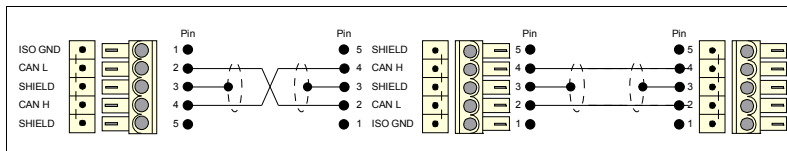

**F. H8/33**

CAN cable to connect a CNC and two drives.

**NOTE.** Note that the connectors of the intermediate modules (when connecting several drives in the bus) receive two wires, in each pin of the CAN connector, coming from each adjacent module. The connectors of the modules at either end only receive one.

Making all these connections will conclude the connection process. See figure.

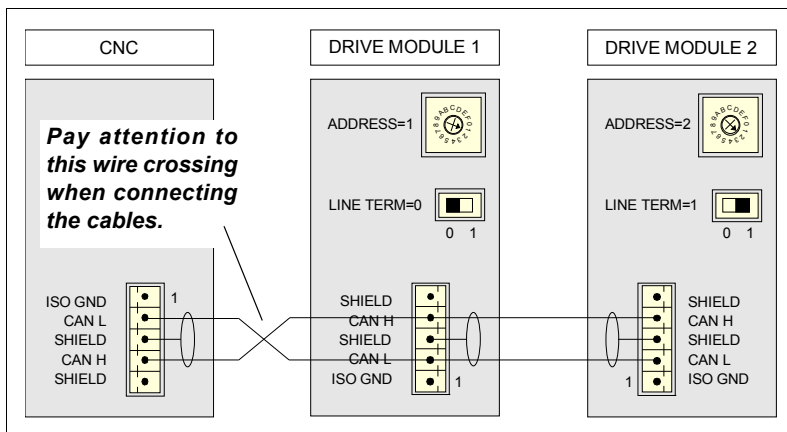

**F. H8/34**

General connection diagram for the CAN bus between the drives and the master device (CNC, etc.). CAN cable connection.

**NOTE.** No more than six drive modules (axes + spindles) can be connected in the CAN bus.



**WARNING.** The bending radius of the CAN cable must always be more than 50 mm.

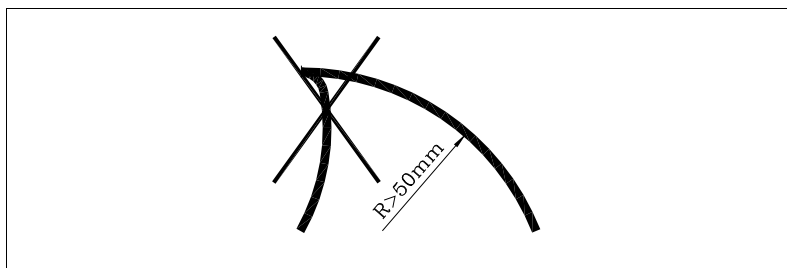

**F. H8/35**

Minimum bending radius of the CAN cable.

8.

INSTALLATION  
Connection of the control and communications signals



DDS  
HARDWARE

Ref.1310

# 8.

INSTALLATION  
Connection of the control and communications signals

### Line terminating resistor (RT)

After connecting the modules, make sure that the external elements connected to the bus have their terminating resistor RT activated.

**NOTE.** The RT switch (located under the CAN connector) of the last drive (usually the one farthest away from the CNC) must be activated (position 1 → switch down) and the rest of the drives connected to the bus must be deactivated (position 0 → switch up).

The CNC (or the ESA panel), located at the end of the bus always has the line terminating resistor activated. See figure F. H8/32.

### Transmission speed selection

From version 07.02, 08.01 and newer, the drive may have a CAN card capable of transmitting data at 1 MB, 800 kBd or 500 kBd.

**NOTE.** This card is not compatible with drive software versions older than 07.02. See chapter 13. **COMPATIBILITY.**

In this data transmission, each drive can receive and transmit 4 IDns (CAN identifiers) or 4 Words (64 bits) through the fast channel.

The communication speed between all the drives being governed by the CNC in the CAN bus is selected by hardware using the “boot” button on top of the CANcard connector. See figure F. H8/36.

**NOTE.** Consequently, the serial connection will no longer be necessary to select the transmission speed.

The parameter associated with the communication speed selection of the CAN bus is QP11 and every time a speed is selected, this parameter is associated the corresponding value. See table T. H8/5 that shows the possible baudrate values that will be shown on the drive display. Chapter 12 of the “dds-software” manual explains the meaning of parameter QP11.

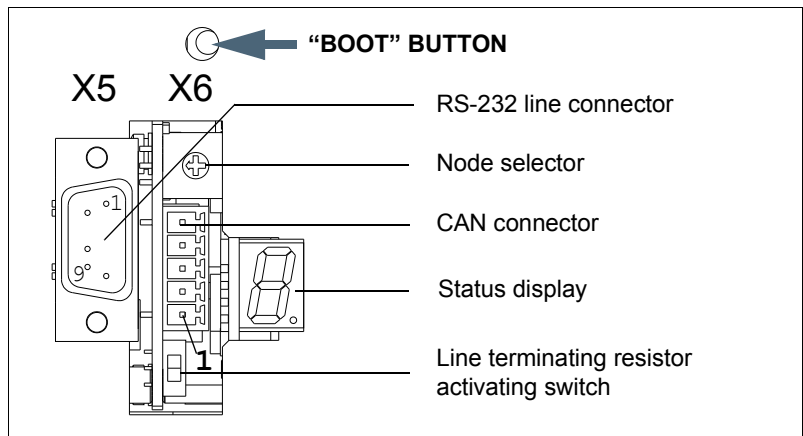

**F. H8/36**

Location of the “BOOT” button at the drive.

### Change of transmission speed

In an initial state (0 state), the display shows certain information that lacks interest for the operator, except the software version, errors and warnings if there are any. Keeping the “boot” button pressed for 3 seconds (long push) it switches to a new state (state 1) that is used for selecting the communication speed and the display shows the speed currently selected.

In this state 1, every time this button is pressed for less than 0.8 seconds (short push), the display shows the next communication speed value that may be selected. Hence, apply several short pushes until the desired speed is displayed.



DDS  
HARDWARE

Ref.1310

Once the display shows the desired speed, apply a long push and QP11 will be assigned its associated value that will be saved into the flash memory of the drive and will reset the drive.

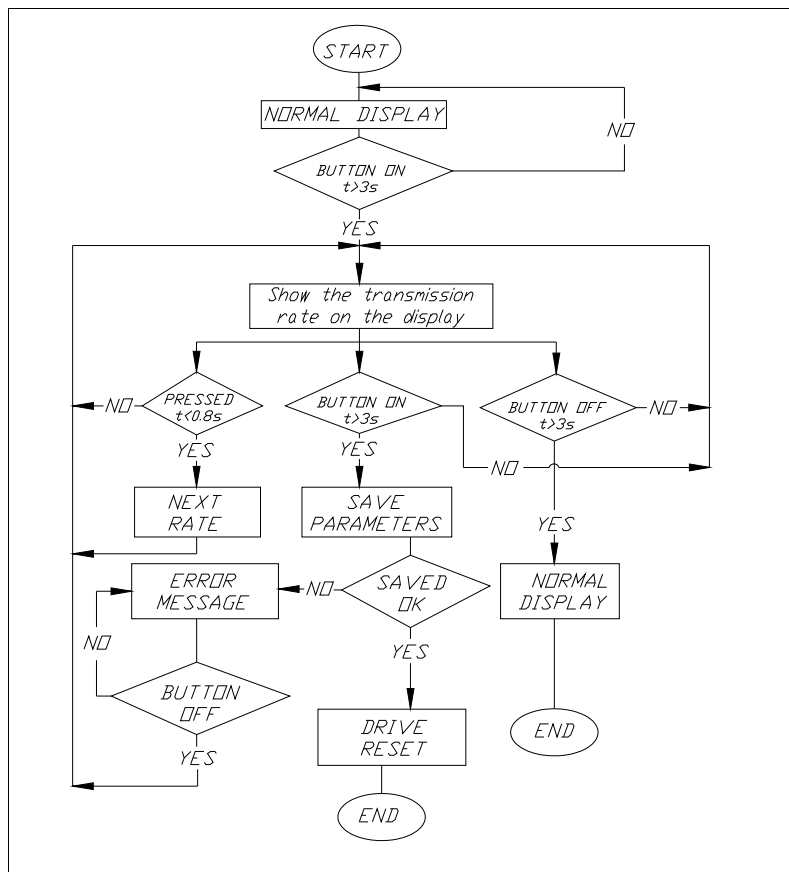

**F. H8/37**

Diagram of the CAN transmission speed selecting procedure.

**Anomalous events during the procedure**

Any error that comes up when saving parameters into flash memory, will be displayed with an error message on the display while the “boot” button is pressed and then it will return to state 1 (speed selection).

**NOTE.** Any attempt to select a value other than those assigned to the possible transmission speeds will generate an error and it will not be selected.

Any change of the communication speed is maintained after the drive is turned off if the command to save parameters has been previously executed successfully.

If, for any reason, the drive is turned off or “reset” in any stage of this procedure, when started up again, the transmission speed value given by QP11 will be the last one that was successfully assigned in previous changes.

The speed change procedure may be ignored (without making any changes) at any time if the command to save parameters has not been executed.

**NOTE.** While in state 1, after 8 seconds without pressing the “boot” button, the drive switches to 0 state and the display shows the initial information.



**INSTALLATION**  
Connection of the control and communications signals



**DDS  
HARDWARE**

**Ref.1310**

# 8.

**INSTALLATION**  
 Connection of the control and communications signals

### Values that may be assigned to the transmission speed

The possible values, supported by the hardware, that may be selected to set the transmission speed are:

#### T. H8/5 Transmission speed with CAN interface. Display at the drive.

Status display	Transmission speed (rate)
1.	1 MBd
8	800 kBd
5	500 kBd

See the values that will be assigned to their associated parameter QP11 in chapter 12. **PARAMETERS, VARIABLES AND COMMANDS** of the “dds-software” manual.

#### CAN connection with an ESA video terminal

The CAN connection of the ESA terminal with FAGOR drives is made through the connector located at the bottom of the VT module. See figure.

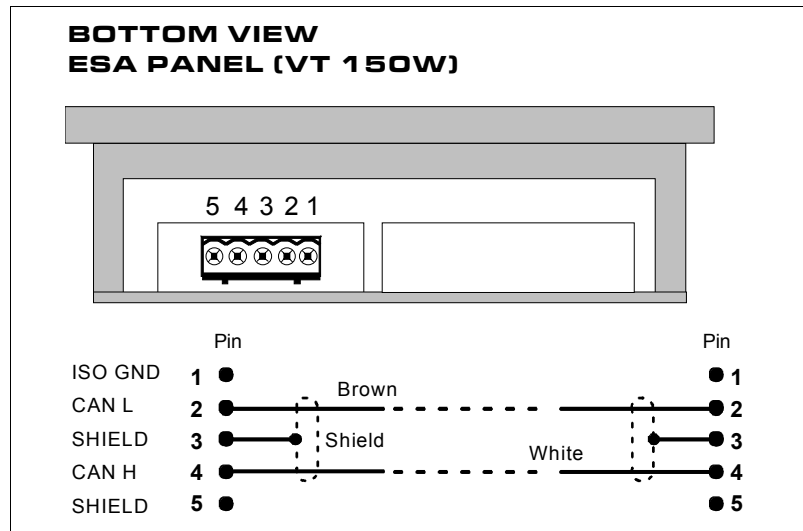

#### F. H8/38

CAN connector of the ESA Video terminal.

#### CAN connection with a FAGOR 8055 CNC

The FAGOR 8055 CNC is connected to the drives via CAN through connector COM1 located on the front panel of the CPU module. See figure:

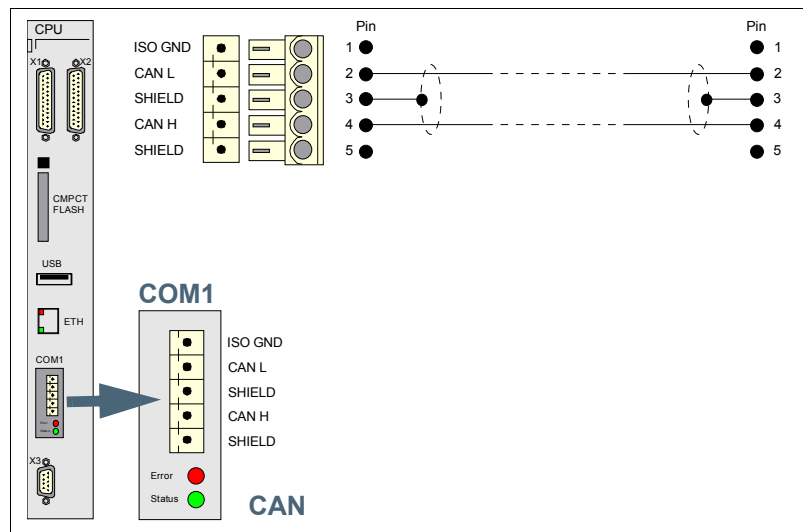

#### F. H8/39

CAN connector of the FAGOR 8055 CNC.

For further information, see the installation manual of the FAGOR 8055 CNC.



**DDS  
HARDWARE**

Ref.1310

### CAN connection with a FAGOR 8055i CNC

The CAN connection of the FAGOR 8055i CNC will be made through the CAN DRIVES connector on the top rear of the module. See figure:

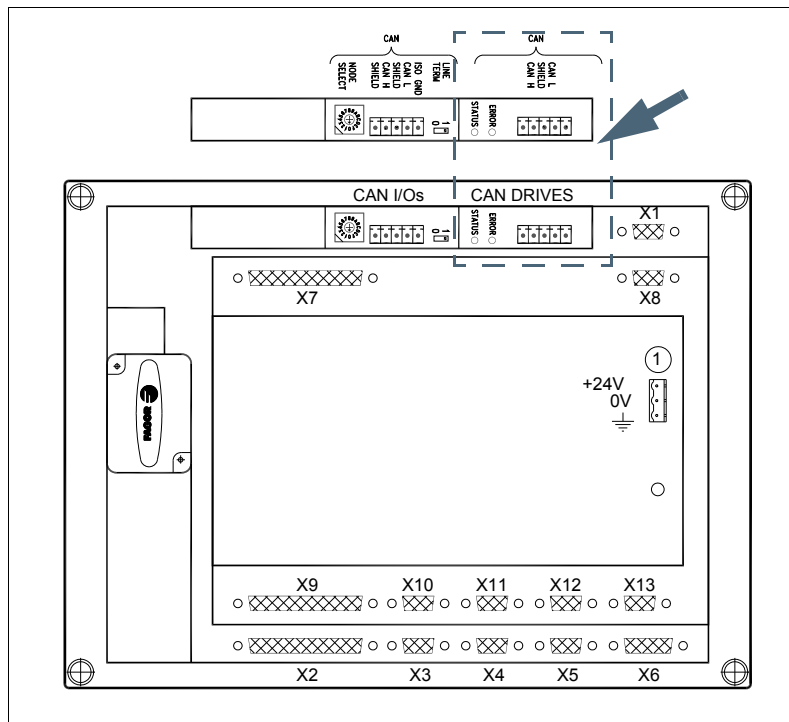

**F. H8/40**

CAN connector of the FAGOR 8055i CNC.

For further information, see the installation manual of the FAGOR 8055i CNC.

# 8.

**INSTALLATION**  
Connection of the control and communications signals



**DDS  
HARDWARE**

**Ref.1310**

# 8.

## RS-422 serial line connection

**NOTE.** This communication interface may be set only between drive modules MMC or CMC and an ESA video terminal as a master element.

The various drive modules and the ESA panel are connected through the RS-232/422 serial port (connector X6) of the drive and the serial port of the video terminal (connector MSP).

The RS-232/422 serial port is implemented only on FAGOR drives in motion control applications (see their front panel).

The connection is made through the RS-232/422 cable.

See chapter 7. **CABLES** of this manual.

It is a tree type connection where the 16-position rotary switch (0-15) of each drive permits selecting the address of each module integrated in it.

**NOTE.** The system communication through RS-232/422 is configured using the WinDDSSetup application for PC. See the “communications” tab of the <preferences> menu in chapter 16. **WINDDSSSETUP** of the “dds-software” manual.

### Particular

In order to establish communication via RS-232 serial line, each drive of the system must be differentiated using the 16-position “NODE SELECT” switch. The direction of the arrow of the switch must coincide with an identifier other than zero, hence assigning a node number that will identify in the system.

If the drive is going to be identified in the SERCOS ring with a number higher than 15 in a tree-like structure that has RS-422 communications line, this value cannot be selected using the rotary “NODE SELECT” switch because it only has 15 positions.

Identifying the axes with addresses higher than 15 requires setting QP13. See this parameter in chapter 13 of the “dds-software” manual.

### Example.

How to identify an axis addressed in position 26 in the system when communicating via RS-422 serial line ?

When the identifier of the axis is higher than 15 (like in this case), QP13 must be set so it meets the ratio:

$$\text{Defined ID} = \text{ID to be selected at the rotary switch} + (15 \times \text{QP13}).$$

Hence, for **defined ID = 26**, select C (same as 11) at the drive's rotary “NODE SELECT” switch and set QP13=1.

In order to establish communication via RS-232 serial line, the direction of the arrow of the switch of the corresponding module must coincide with the zero identifier.

**NOTE.** The module must be reset in order for any change made on the rotary switch to be effective.

### Interconnection

Use the RS-232/422 cable to connect all the drives that will be governed by the video terminal. See chapter 7. **CABLES** of this manual.



DDS  
HARDWARE

Ref.1310

### RS-232/422 serial line connection with an ESA video terminal

The RS-232/422 connection of the ESA terminal with the drives is made through the MSP connector located at the bottom of the VT module. See figure:

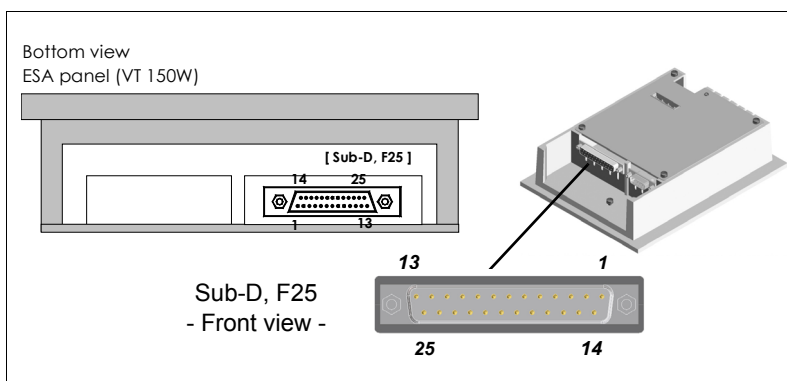

#### F. H8/41

MSP connector of the ESA video terminal for the RS-422 connection.

The MSP serial port (Multi Serial Port) is a part of any ESA video terminal and is used to connect it with other devices. Hence, the project is transferred from the PC to the VT through this port.

This port is accessed from a 25-pin female SUB-D connector and may establish communication with other devices through RS-232, RS-422, RS-485 and C.L. (TTY-20 mA) protocols.

**NOTE.** Pin 16 does not contemplate communicating with any type of load. Any disturbance going into this pin can damage the video terminal and the process.

The pinout of the MSP connector is described in the following table:

#### T. H8/6 Pinout of the MSP connector.

\* C.L. means < Current Loop >.

Pin	Signal	Pin	Signal
1	Not connected	14	IKT OUT
2	TxRS232 OUT	15	IKR OUT
3	RxRS232 IN	16	+5 V DC (reserved)
4	RTS RS232 OUT	17	Not connected
5	CTS RS232 IN	18	* R x C.L. +IN
6	Not connected	19	Not connected
7	GND	20	Not connected
8	Not connected	21	Not connected
9	* Tx C.L. + OUT	22	TxRx485+IN/OUT
10	TxRx485-IN/OUT	23	TxRS422 +OUT
11	* Tx C.L. - OUT	24	RxRS422 -IN
12	TxRS422 - OUT	25	* R x C.L. - IN
13	RxRS422 +IN		

# 8.

**INSTALLATION**  
Connection of the control and communications signals



**DDS  
HARDWARE**

**Ref.1310**

**8.**

**INSTALLATION**  
Connection of the control and communications signals

**RS-232/422 serial line connection with a drive**

The RS-232/422 connection of the drive (only MMC or CMC models) is made through the X6 connector on the front panel of the module. See figure:

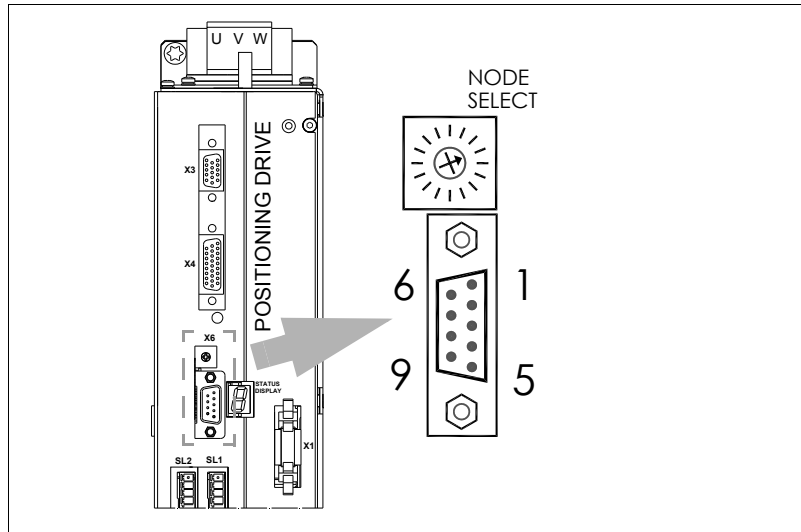

**F. H8/42**

Connector X6 of the drive (MMC or CMC) for the RS-232/422 connection.

This port is accessed through a 9-pin male SUB-D type connector and can establish communication with other devices using the RS-232/422 protocol.

The pinout of connector X6 (RS-232/422 serial line) is described in table **T. H8/7**.

**T. H8/7** Pinout of connector X6 (RS-232/422).

Pin	Signal	Pin	Signal
1	Not connected	6	TxD 422
2	RxD 232	7	#TxD 422
3	TxD 232	8	RxD 422
4	+5 V ISO	9	#RxD 422
5	GND ISO		

**RS-232 serial line connection between a PC and an ESA VT**

To make this connection is essential for transferring the communication driver and the project.

The connection is made through the MSP connector at the bottom of the VT module and the RS-232 serial line connector of the PC.

The connection must be made according to the diagram shown in chapter **7. CABLES** in this manual.

**RS-232 serial line connection between a PC and the drive**

This connection is necessary in order to establish communication between the WinDDSSetup application for PC and the drive. This connection may be used to set up the drive.

The connection must be made according to the diagram shown in chapter **7. CABLES** in this manual.



DDS  
HARDWARE

Ref.1310

## 8.7 Check the installation

Check the installation:

- Mechanical fixtures for the whole system
- Distances
- Tighten all the mounting screws with their corresponding tightening torque.
- Electrical connections and wiring:
  - Connection of protection wires
  - Fuses, value and type
  - Ends of the wires of the cables
  - Cables and connectors installed correctly
  - Mechanical latches of the connectors
  - Control cables
  - Necessary shielded connections according to EMC
  - Compliance with electromagnetic compatibility measures
  - Satisfactory covers and seals of the electrical cabinet to reach the necessary protection level.

**8.****INSTALLATION**  
Check the installation**FAGOR** **DDS  
HARDWARE****Ref.1310**

# 8.

## INSTALLATION



DDS  
HARDWARE

Ref.1310

See section on - **SAFETY CONDITIONS** - at the beginning of this manual.

The references of drive modules certified according to the STO safety function are unmistakably determined in the declaration of conformity and in the TÜV certificate. Both documents may be found at the beginning of this manual.

They can also be physically identified because all these units carry the TÜV seal on their outside label.

## 9.1 STO safety function

9.

FUNCTIONAL SAFETY  
STO safety function

The STO (**Safe Torque Off**) is the only safety function Fagor Automation drives AXD/SPD offer according to the standard IEC 61800-5-2.

This safety function may be used to safely disconnect the motor torque and it is always active.

### STO first channel

It is the external main contactor - **KM1** that will remove input power to the power supply (PS, XPS or RPS). To perform the monitoring, the contactor has to have an N.C. contact (**N**ormally **C**losed) that complies with IEC 60947-4-1 or with IEC 60947-5-1.

### STO second channel

It is **pin 2 “Drive Enable”** of connector X2 of the AXD/SPD, that will disable motor torque. The N.C. contact (**N**ormally **C**losed) may be monitored through pins AS1, AS2 of connector X7.

### PL d or SIL 2

When a machine requires a PL d or SIL 2, it requires an external safety controller PL d or SIL 2 that disconnects the motor torque in the two channels. The safety controller must watch the status of each channel (only when demanded by the STO) keeping the motor torque off in case of failure.

### Safe state

The safety controller may use the “Torque OFF” state to achieve a safe state of the machine.

### Brake

Requesting the STO safety function while the servo system is moving, and there is no brake causes the motor to only stop by friction (coasting).

If there are external forces on to the motor (e.g. vertical axis), where an unwanted movement (e.g. due to gravity) can cause a risky situation, this must not be used without additional measures to protect against dropping.

A risk analysis of the machine may require a brake to help stop the motor.

### Failure reaction and failure reaction time

After a request from STO, if one of the channel fails, its corresponding feedback contact opens. The safety controller does not allow engaging the system and consequently, the failure reaction time is zero. Do not mistake it with the response time of the STO function itself that could be of some ms. See **9.7 Response time**.

## 9.2 Interface

**DRIVE MODULE**

**X3**  
**X4**

**X5** **X6**  
NODE  
OUT  
IN

**STATUS DISPLAY**

**SL2** **SL1**

**X1**

**X7**  
AS1  
AS2

**X2**  
GND  
DRIVE ENABLE  
SPEED ENABLE  
DR. O.K.  
0 V  
+24 V DC

**SAFE TORQUE OFF (second channel input)**

**Aerial male connectors X2 and X7. Mechanical data.**

AXD/SPD	
Connector data	
Nr of poles (X2/X7)	8/2
Gap (mm)	5
Min./max. tightening torque (Nm)	0.5/0.6
Screw thread	M3
Min./max. section (mm <sup>2</sup> )	0.2/2.5

**Female connector X2. Electrical data.**  
8-pin connector whose 3 pins to consider are:

<b>1</b>	GND	0 volts reference for Drive Enable and Speed Enable
<b>2</b>	Drive Enable	24 V DC. Motor current enable 0 V DC. STO (Safe Torque Off, 2nd channel input) 24 V DC ±10%, I < 50 mA.
<b>3</b>	Speed Enable	24 V DC. Drive speed enable. Out of certification.

See sub-section:  
**X2 connector** in chapter 3 of this manual.

**Female connector X7. Electrical data.**  
2-pin (AS1-AS2) connector associated with the (N.C., Normally Closed) contact of a safety relay with guided pins of free potential. The state of the of the Drive Enable input is open high "H".

Dielectric strength 1800 Vrms

**Contact data**  
Current I<sub>max</sub> = 1 A  
Voltage = 24 V DC

See sub-section:  
**X7 connector** in chapter 3 of this manual.

**FUSE (250V) 2,5AGF**

**DANGER HIGH VOLTAGE DISCHARGE TIME > 4 Min**

**FAGOR**

9.

FUNCTIONAL SAFETY  
Interface

**FAGOR**

DDS  
HARDWARE

Ref.1310

F. H9/1

Interface of the STO safety function, second channel.

### 9.3 Examples

**Note.** These examples use an external safety relay.

#### Example 1. STO (Safe Torque Off) safety function with PL d or SIL 2

This STO safety function corresponds to an uncontrolled stop in accordance with stop category 0 of IEC 60204-1.

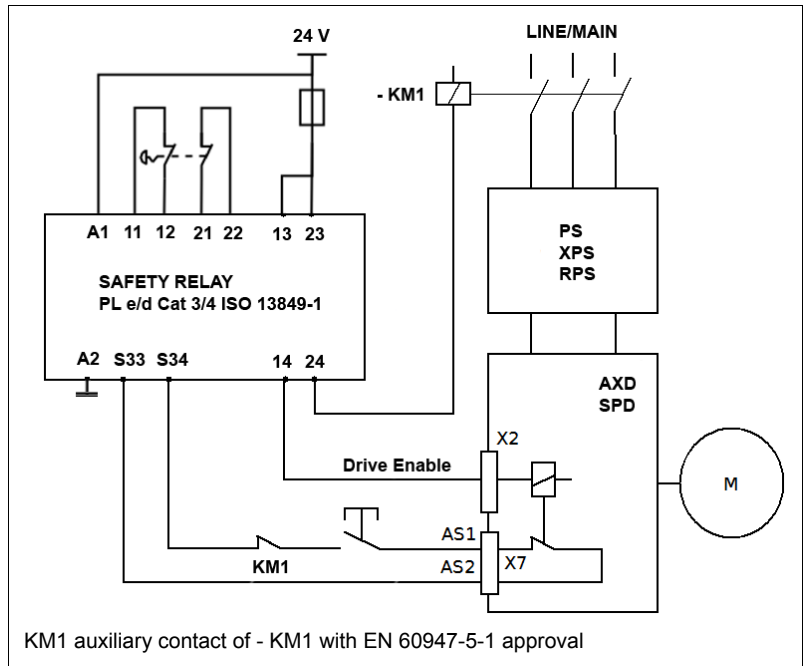

#### F. H9/2

STO safety function (with PL d or SIL 2) monitoring the status of both channels with an external safety relay.

#### Example 2. SS1 (Safe Stop 1) safety function with PL d or SIL 2

This SS1 safety function corresponds to a controlled stop in accordance with stop category 1 of IEC 60204-1.

When requiring an SS1 safety function, it is necessary to use a safety relay with delayed contacts and non-delayed contacts so as to do a controlled stop before removing motor torque. See an example with this type of operation.

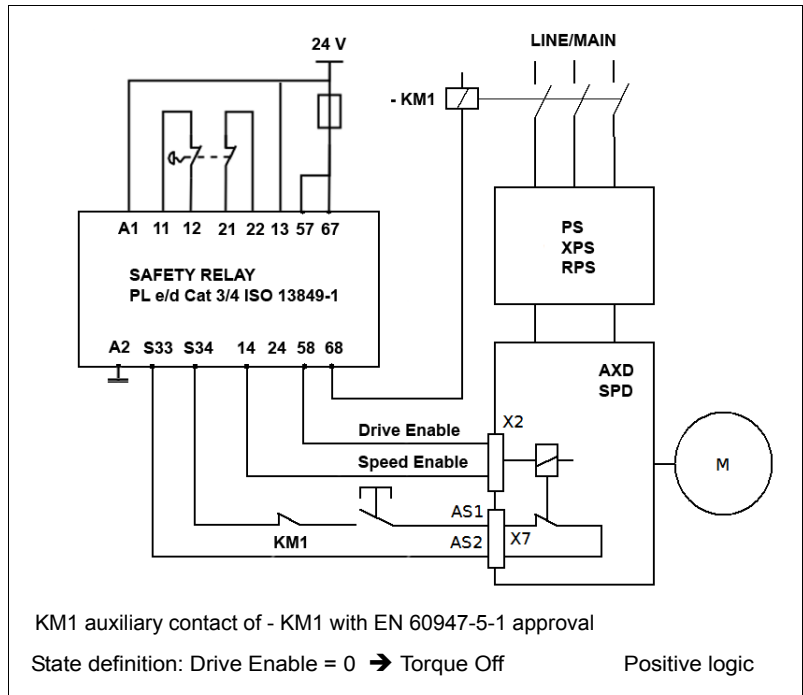

#### F. H9/3

SS1 safety function (with PL d or SIL 2).



DDS  
HARDWARE

Ref.1310

**Considerations to bear in mind in the previous examples**

- The auxiliary 24 V DC power supply must be independent from the power controlled by external main contactor - KM1.
- To achieve PL d or SIL 2, the safety controller must check the feedback of the STO safety function; i.e. the feedback of the Drive Enable (state of the internal contact through AS1- AS2) and the feedback of external main contactor - KM1 (status of the KM1 contact) at all the requests of the STO safety function.

**9.****FUNCTIONAL SAFETY**  
Examples**FAGOR** **DDS  
HARDWARE****Ref.1310**

## 9.4 Precautions

### Safe Torque Off (STO)



---

**DANGER.**

- ❑ The lack of Drive Enable does not isolate the system from mains nor does it discharge the DC BUS.
  - ❑ Opening the main external contactor - KM1 isolates the system from mains, but the DC BUS is still alive for the time period indicated on the front plate of the unit.
- 

### DDS system in general

The precautions to bear in mind regarding the installation of Fagor Automation's Digital Drive System are described in the section on - **SAFETY CONDITIONS** - in this manual.

9.

FUNCTIONAL SAFETY  
Precautions



DDS  
HARDWARE

Ref.1310

## 9.5 Risk analysis

The machine manufacturer must run a thorough analysis of the possible risks of the whole system and take the necessary measures to ensure the safety of the machine as a whole. The residual risk of the machine remaining after carrying out all the protection measures taken.

### Residual risk of AXD/SPD drive

The residual risk regarding the AXD/SPD drive may be prevented if necessary with additional external measures.

- ❑ Only a simultaneous failure of two IGBT's (the top one and the bottom one of the output stage) can cause the axis to move for an instant ( < 180 electrical degrees). If accessing the machine while stopping is risky (according to risk analysis), take the necessary measures.
- ❑ The action of external forces on to the motor (eg. gravity on vertical axes) causing unwanted movement of the motor can cause a risky situation if it is possible to access the machine. Take the necessary measures to ensure protection against a drop.
- ❑ The unit must always be replaced by another one of the same type. Otherwise, the parameters will not match the safety configuration and its performance may be risky.

**9.****FUNCTIONAL SAFETY**  
Risk analysis**FAGOR** **DDS  
HARDWARE****Ref.1310**

## 9.6 Technical data of the safety function

Fagor Automation drives AXD/SPD only offer the safety function STO (Safe Torque Off) defined according to the standard IEC 61800-5-2.

To calculate the Performance Level (PL of ISO 13849-1) and/or the Safety Integrated Level (SIL of IEC 62061) use the following data referred to AXD/SPD drives given in the following tables:

**T. H9/1** Calculation data according to IEC 61508 and IEC 61800-5-2.

Lifetime	years	20
SFF (Safe Failure Fraction)	%	99
PFH (Average frequency of a dangerous Failure per Hour)	1/h	1.5654E-07
HFT (Hardware Fault Tolerance)		1
SIL (Safety Integrity Level)		2

This data is calculated considering a contactor with 500,000 life cycles and a demand from the STO safety function every 5 minutes running 24 hours a day. For higher demands, check with Fagor Automation.

**T. H9/2** Calculation data according to ISO 13849-1.

PL (Performance Level)		d
MTTFd (Mean Time To dangerous Failure)	years	21.4
DC (Diagnostic Coverage)	%	98
Category		3
CCF (Common Cause Failure)		80

**Note.** Bear in mind that PFH and MTTFd are calculated values and show the probability of failure. This does not guarantee the useful life of a particular product.

The external main contactor - KM1 installed must comply with standard IEC 60947-4-1 (if it is a mirror-contact type) or with IEC 60947-5-1 (if its contact is joined mechanically).

The Drive Enable has been designed to be used in high-demand mode (more than once a year) according to standard IEC 61800-5-2.

9.  
**FUNCTIONAL SAFETY**  
 Technical data of the safety function



DDS  
HARDWARE

Ref.1310

## 9.7 Response time

FAGOR recommends measuring the response time of the implemented safety functions. This measurement must be taken from the instant the danger condition takes place (e.g. door opened) to the instant the safety function is executed (e.g. machine stopped). This time will depend on the design.

The following table shows delay data related to both channels in the indicated conditions.

**T. H9/3** Delay data.

	<b>Delay</b>	<b>Comment</b>
Internal channel (AXD/SPD drive)	< 15 ms	Measurement taken in a circuit equivalent to that of figure <b>F. H9/2</b> with a safety relay for emergency stop from Telemecanique™. The delay of the internal circuit is less than 15 ms.
External channel (main contactor)	Depends on used - KM1 contactor	Measurement taken with a Schneider™ contactor. The delay of the DDS system between the actual opening of the contacts and the "Torque Off" is less than 35 ms.

# 9.

**FUNCTIONAL SAFETY**  
Response time



**DDS  
HARDWARE**

**Ref.1310**

## 9.8 Cabling and grounding

9.

**FUNCTIONAL SAFETY**  
Cabling and grounding

### Safe Torque Off (STO)

The following recommendations must be taken into account when designing the STO safety function:

- A fuse **MUST** be installed that can limit the current of at least the STO channel input of the AXD/SPD drive (pin 2 “Drive Enable” of X2). FAGOR recommends installing a “1 A” slow fuse to limit the input current through this pin. In the case of the figure where a safety relay has been used, the fuse may be installed on the 24 V DC line to activate both the AXD/SPD input and the external main contactor so it also protects the internal contacts of the safety relay.
- Try keeping power cables and signal cables apart from each other.
- Run the STO channels activating cables through separate conduits
- Install an intermediate auxiliary relay to activate the coil of the contactor for high power units where the consumption current and peak current of the external main contactor is significant; although the mirror contact in series with the start button must belong to the external main contactor. Never to the intermediate relay.

### DDS system in general

The instructions regarding the cabling and grounding when installing Fagor Automation's Digital Drive System are described in chapter **8. INSTALLATION** in this manual.

## 9.9 Commissioning

Check that each of the two channels of the STO, i.e. - KM1 and Drive Enable, separately, remove motor torque.

Also check the feedback of each channel.

Document the tests of the safety function on the minutes (record).

**9.****FUNCTIONAL SAFETY**  
Commissioning**FAGOR** **DDS  
HARDWARE****Ref.1310**

## 9.10 Maintenance, repair and analyze hazardous events

Although it is not required due to its low probability, FAGOR recommends to demand the STO safety function at least once every 24 hours in order to detect possible failures in the STO circuit.

The external main contactor - KM1 and Drive Enable have electromechanical components that wear out in time. Their failures due to deterioration must be detected by the diagnostics of the safety controller.

The test interval of the Drive Enable is the same as its useful life, i.e. 20 years. After this period, the Drive Enable is no longer reliable.

The useful life (mission) of the STO safety function is 20 years. After that time, the safety function will no longer be valid. The expiration date must be calculated by adding 20 years to the date shown on the version label of the unit. Write down this value in the maintenance plan of the installation. Do not use the safety function after that date.

If the STO safety function has been implemented according to ISO 13849 PL d (see examples in this chapter), **the safety controller will detect an error** at the Drive Enable reading AS1-AS2 or and error at external main contactor - KM1 with its feedback contact **only when carrying out a demand of the STO**.

If the external main contactor - KM1 breaks down, it must be replaced.

### Repair

- Neither the user nor the OEM is authorized to repair any AXD/SPD modules, not even to replace boards.
- If the Drive Enable circuit breaks down, the AXD/SPD must be replaced and commissioning test and registering must be done again.

9.

FUNCTIONAL SAFETY

Maintenance, repair and analyze hazardous events

## 9.11 Decommission and disposal

The machine manufacturer must indicate the procedure to be used for decommissioning the machine.

Respect environmental regulations. Observe that the AXD/SPD drive modules do not carry batteries.

Bear in mind the storage and shipping requirements when disposing of the AXD/SPD units.

**9.****FUNCTIONAL SAFETY**  
Decommission and disposal**FAGOR** **DDS  
HARDWARE****Ref.1310**



# CONNECTION DIAGRAMS

# 10

## 10.1 SPD modular drive with FM7 asynchronous spindle motor

Connection diagram of an SPD modular drive with an FM7 asynchronous spindle motor that has TTL encoder feedback.

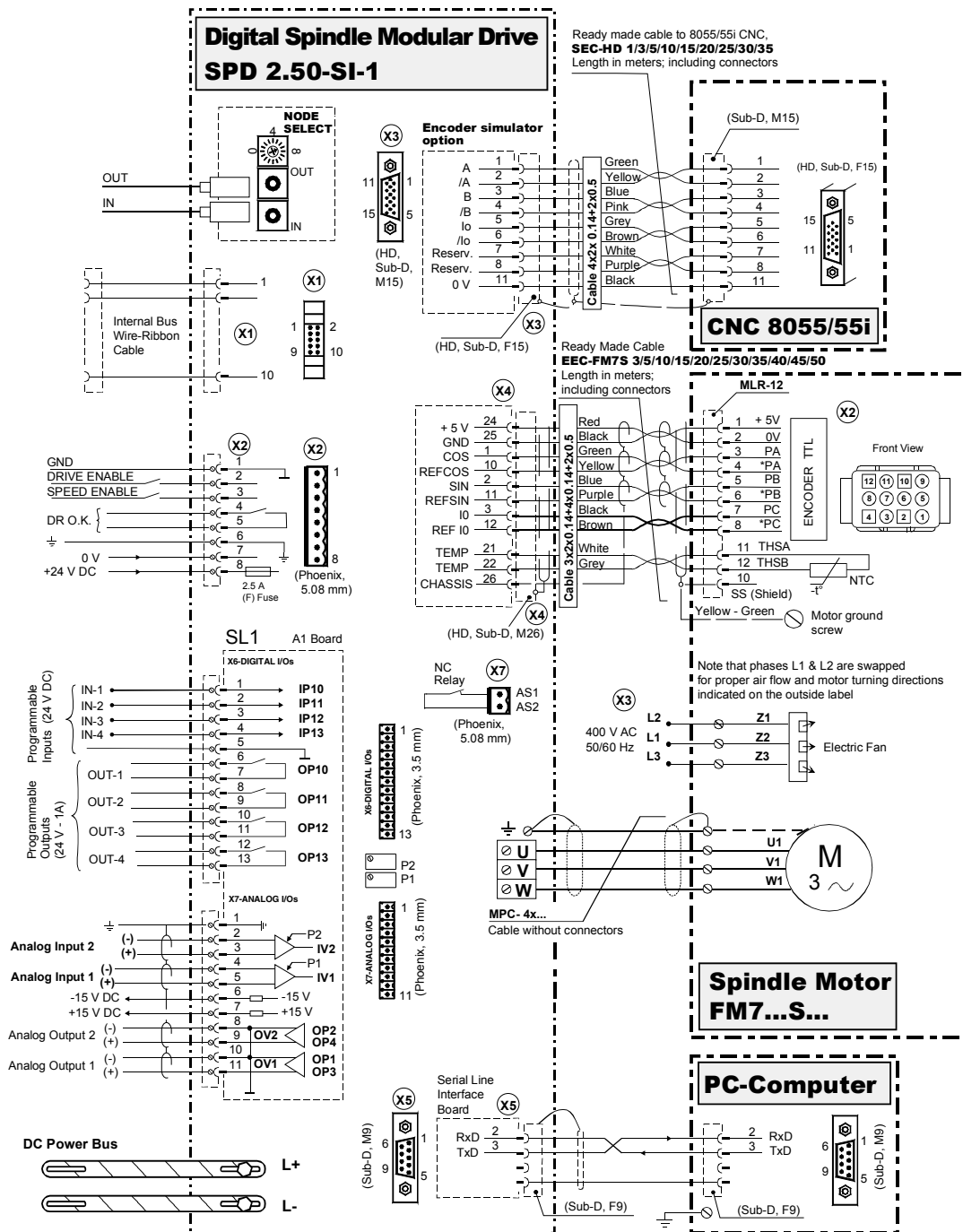

F. H10/1

Connection of an SPD modular drive with an FM7 asynchronous spindle motor with TTL encoder.



DDS  
HARDWARE

Ref.1310

## 10.2 AXD modular drive with FKM synchronous axis servo motor

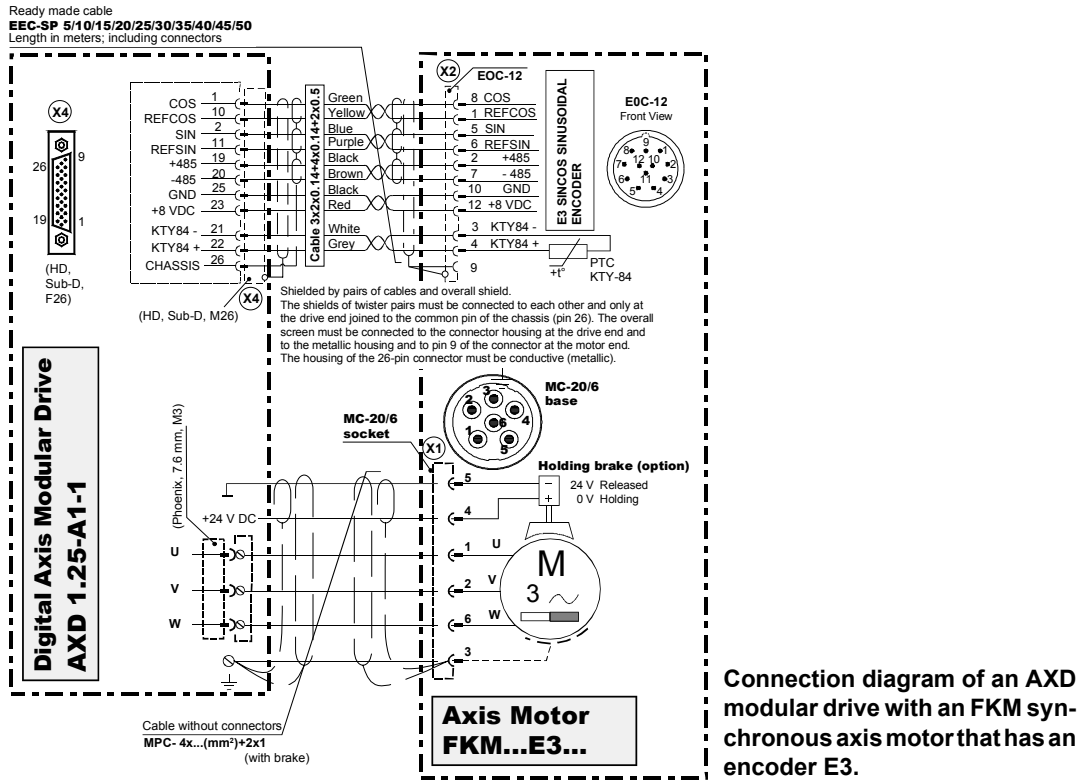

### F. H10/2

Connection of an AXD modular drive with an FKM synchronous axis servo motor with encoder E3.

## 10.3 AXD modular drive with FXM synchronous axis servo motor

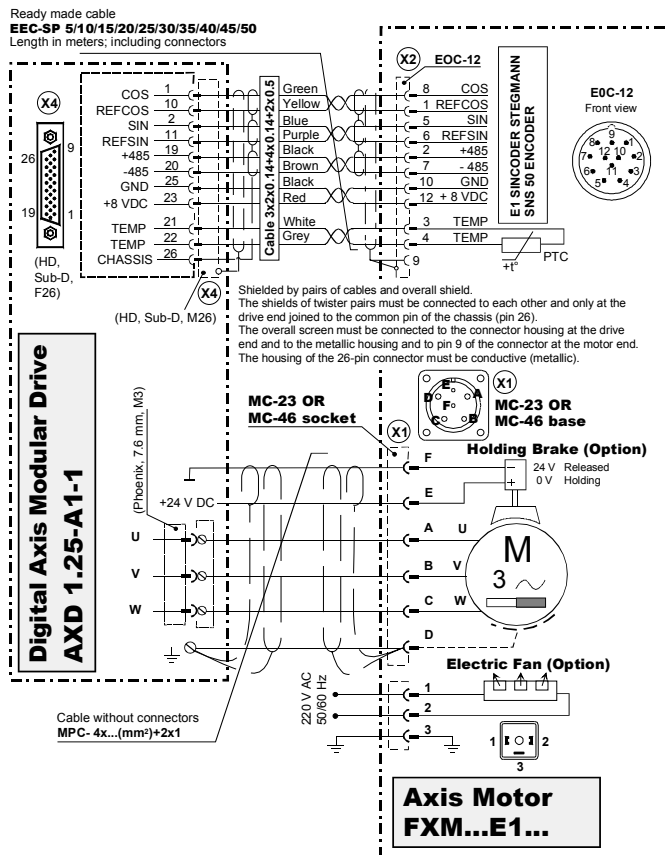

### F. H10/3

Connection of an AXD modular drive with an FXM synchronous axis servo motor with encoder E1.

10.

CONNECTION DIAGRAMS

AXD modular drive with FKM synchronous axis servo motor



DDS  
 HARDWARE

Ref.1310

# 10.4 SCD compact drive with FM7 asynchronous spindle motor

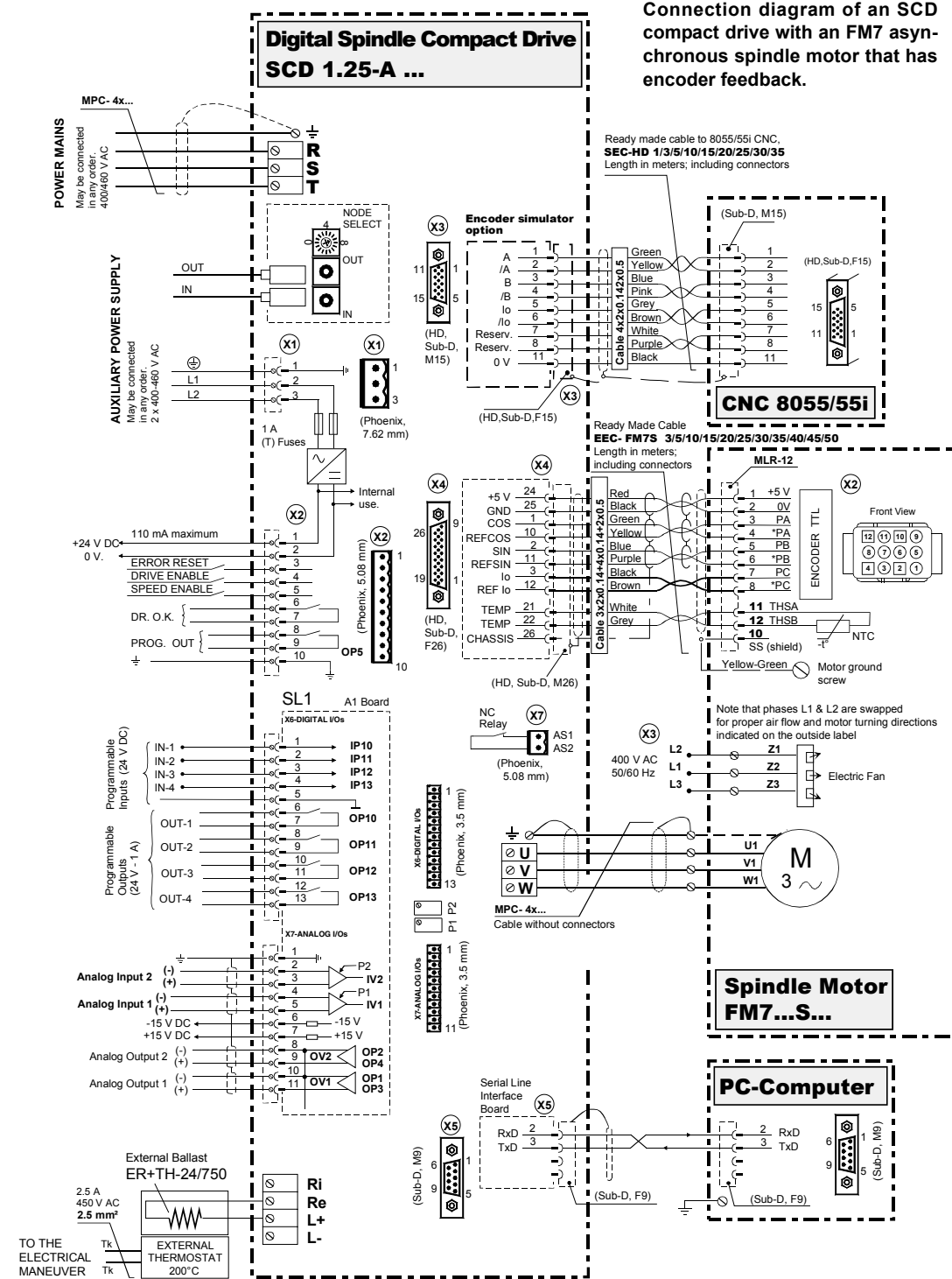

## F. H10/4

Connection of an SCD compact drive with an FM7 asynchronous spindle motor with TTL encoder.



**DDS  
HARDWARE**

Ref.1310

# 10.5 ACD compact drive with FKM synchronous axis servo motor

## 10.

### CONNECTION DIAGRAMS

ACD compact drive with FKM synchronous axis servo motor

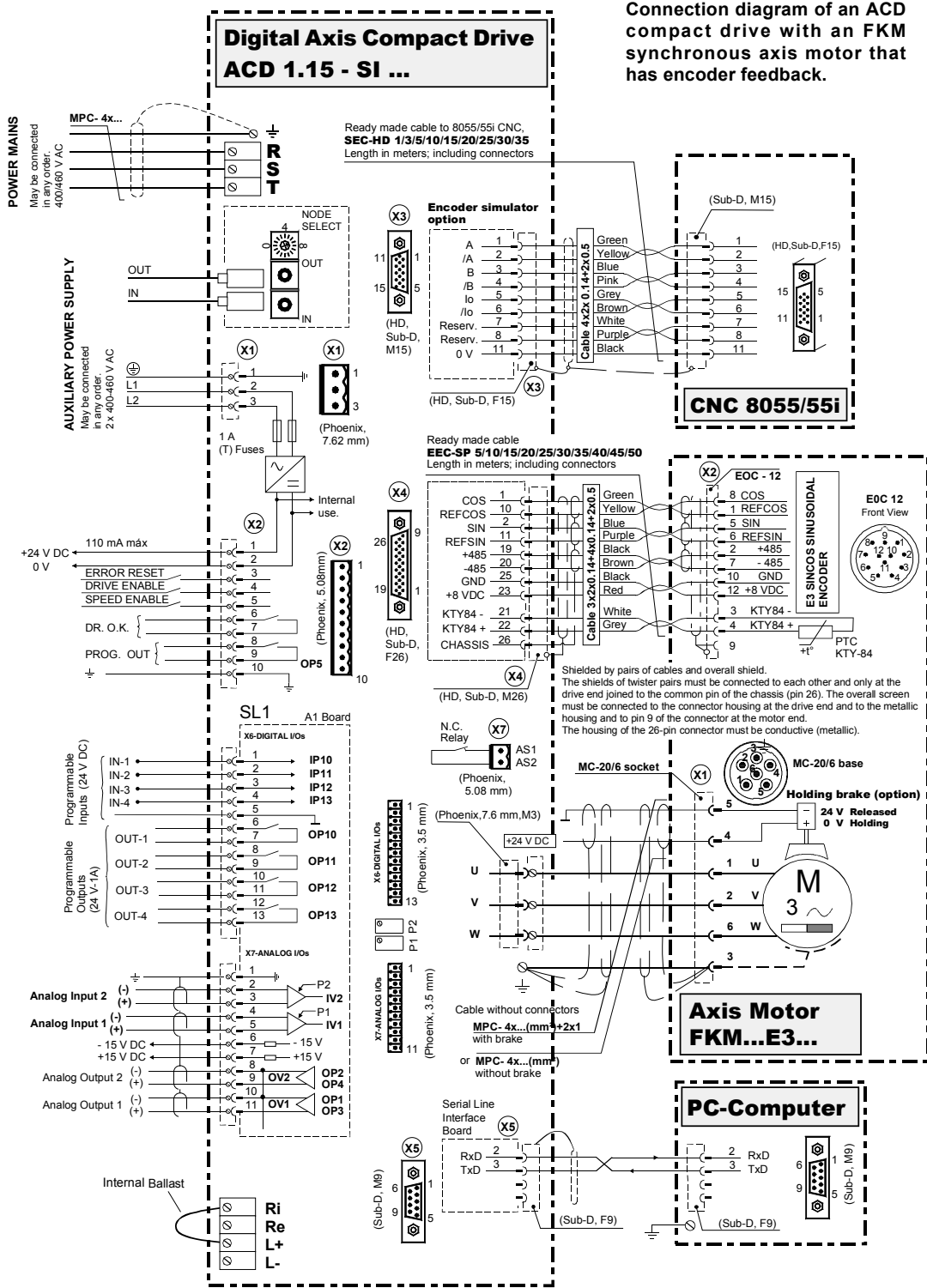

### F. H10/5

Connection of an ACD compact drive with an FKM synchronous axis servo motor with encoder.



DDS  
HARDWARE

Ref.1310

# 10.6 ACD compact drive with FXM synchronous axis servo motor

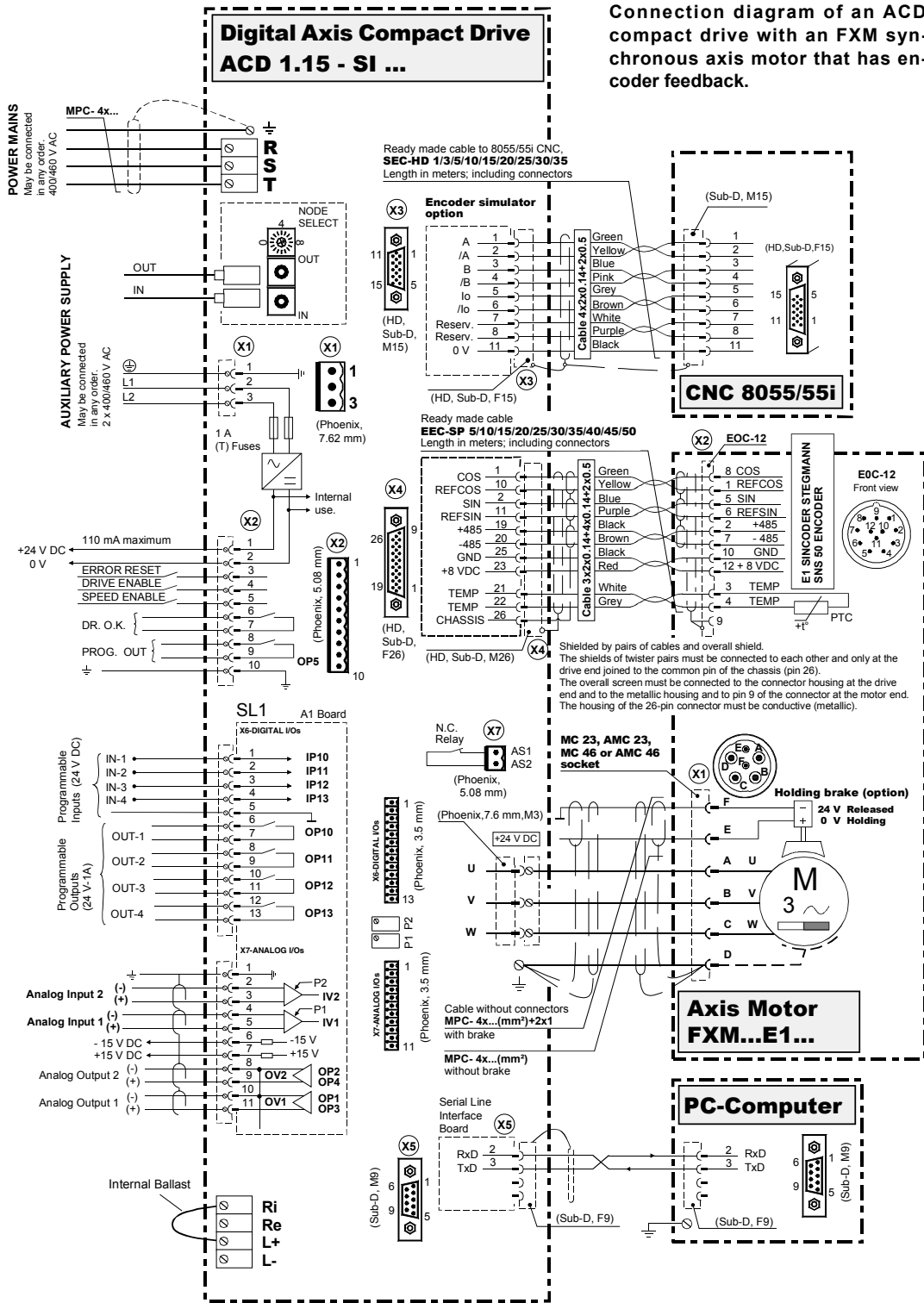

## F. H10/6

Connection of an ACD compact drive with an FXM synchronous axis servo motor with encoder.



DDS  
HARDWARE

Ref.1310

## 10.7 Electrical cabinet. Diagrams

# 10.

**CONNECTION DIAGRAMS**  
 Electrical cabinet. Diagrams



### DANGER.

**The diagrams of this chapter do not meet the European Machinery Directive 2006/42/EC.**

Complying with the European Machinery Directive usually requires PL d or SIL 2 (milling machines and lathes). The AXD/SPD reaches PL d or SIL 2 (see models in the Declaration of Conformity). An external safety controller PL d or SIL 2 is necessary as well as bearing in mind the concepts in chapter 9. **FUNCTIONAL SAFETY.**

Before showing the diagrams of the electrical cabinet, described later on, read this brief explanation of the actions followed by the modules on system start-up. All the references to electrical devices, for example to the switch - S1, power contactor - KM1, relay - KA3 appear in later diagrams. Consult these diagrams to interpret the explanatory texts.

### Voltage for control circuits

- **Power** with 24 V the internal control circuits of each modular drive through the power supply module or of each compact drive through its integrated power supply, closing the main power switch or main key - S1. Refer to the diagrams shown later to locate - S1 in the system.

Internally, each module checks its hardware and configuration.

If the status of each drive is OK and no errors have occurred, each drive closes its DR.OK contact.

If the status of **all** the drives that make up the DDS system is correct and no errors have occurred, each one of them lets the power supply know through the internal bus (only the modular drives). If the power supply does not register any errors either, it closes its "System OK" contact.

The power supply then starts charging the power bus with a "Soft-Start".

- **Activate** the control input "Speed Enable" of each drive and the "System Speed Enable" input of the power supply - see the location of the relay - KA2 in the diagrams. - The CNC, in turns, enables the SPENA mark -.
- **Activate** the control input "Drive Enable" of each drive - see the location of the relay - KA3 in the diagrams. - The CNC, in turns, enables the DRENA mark -.

**NOTE.** The motor is now ready to follow the velocity command given by the CNC.

All the following diagrams for power and control circuits in the electrical cabinet described in this chapter are only **orientation purposes** for the technician designing the machine and they may be further completed or simplified at will according to each application.

### Emergency line

The purpose of relay - KA1 is to confirm that the system is in running condition both mechanically and electrically. This relay closes its contact when **all and each of the** following conditions are met:

- The System\_OK contact of the power supply is closed.
- No emergency has been activated.
- The spindle motor temperature is correct (it does not overheat) and
- none of the axes of the machine has reached its limit switch.



DDS  
HARDWARE

Ref.1310

**NOTE.** Observe that a push-button (N.O., **N**ormally **O**pen) is included in parallel with the limit switches for disabling (via PLC) the movement of the axes of the machine in the opposite direction.

After activating the relay - KA1, its associated contact closes, to allow supplying three-phase power to the system by pressing the ON button closing the contactor - KM1. To remove power, press the OFF button.

### Error reset

When an error appears at any drive, its “Drive OK” and, therefore, the “System OK” contact of the power supply that feeds it will be open. The relay - KA1 will be deactivated and its associated contact open and will not be possible to supply power to the power supply until the cause of the error is eliminated, as long as it is a non-resettable error.

**NOTE.** Some of these errors (called non-resettable) may be eliminated by applying 24 V DC to the Error Reset pin of the power supply. See chapter 14 in the “man\_dds\_soft.pdf” manual for further information on these errors.

The contact associated with the ON button resets the errors. This procedure may close the “Drive OK” and “System OK” activating the - KA1 relay and, while ON is still pressed, enable - KM1.

**NOTE.** This circuit configuration joins the error reset and the system power-up in a single push-button.

### Activating the “System Speed Enable” of the power supply and the “Speed Enable” of the drives

The “System Speed Enable” signal of the power supply is activated after closing the contact KA2 with 24 V DC as a result of activating the relay - KA2. Observe that KM1 has been closed earlier.

Now, the CNC may enable each axis (CNC Enable) and enable the “Speed Enable” signal of each drive by means of relays - KA4, - KA5, - KA6 and - KA7.

### Activating the “Drive Enable” of the drives

Closing the contact associated with - KA2 excites the relay - KA3 with 24 V; this relay activates the “Drive Enable” signal of all the drive modules.

**NOTE.** Observe that - KA3 is a delayed-deactivation relay where the desired delay time  $t$  may be programmed. It may be used to keep contactor - KM1 closed while braking a system for the necessary number of seconds to give the power supply enough time to return the excess energy to mains as long as the system has regenerative power supplies and it is connected to mains (S1 closed) obviously. The delay time “ $t$ ” to program relay - KA3 must be slightly longer than the time it takes the system to come to a full stop.



**INFORMATION.** In the diagrams provided later on, the green ON light indicates that the “System Speed Enable” of the power supply is activated; in other words, the “Speed Enable” in each drive related to it and the SPENA signal of the CNC (sent to each drive via SERCOS or CAN) are activated and there will then be motor torque (Drive Enable signal at each drive and DRENA signal of the CNC). The red OFF light indicates that all the previous signals are disabled.

**NOTE.** Remember that a drive will only respond to an external velocity command when the Drive Enable, Speed Enable and System Speed Enable signals (besides the DRENA and SPENA signals of the CNC) are active (24 V DC).

# 10.

CONNECTION DIAGRAMS  
Electrical cabinet. Diagrams

**FAGOR**

DDS  
HARDWARE

Ref.1310

# 10.

A stop may be caused by:

- **opening the main power switch - S1**, one or several fuses have blown or there is simply a power outage while the system is running. The motor brakes with emergency ramps if they were initially set by parameters. Regardless of the power supply being used, it will not be possible to return to mains the excess energy generated by braking (remember that the mains connection has been opened). It causes a voltage rise at the power bus as a result of saving that energy at the capacitors.

**NOTE.** Remember that the energy saved at the capacitors responds to the formula: **Energy saved = 0.5 C·V<sup>2</sup>**

When exceeding a certain bus voltage (760-768 V DC) the Ballast circuit is activated to dissipate that excess of energy in a resistor (internal or external) and the motor performs a controlled stop (with motor torque).

Even when having activated the Ballast circuit, if there is a problem with it (e.g. poor connection of the external resistor) the bus voltage would keep rising until reaching its maximum value allowed (790 V DC) and would issue error **E215** for bus over-voltage. It would deactivate the "Drive Enable" function and the motor would stop by friction without motor torque.

- **Opening of power contactor - KM1** because the contact KA1 associated with the relay - KA1 has opened. The braking operation would be the same as in the previous case when using a PS-65A or a PS-25B4 power supply. If it is a regenerative power supply (XPS or RPS) it brakes with emergency ramps if they have been previously set by parameters. The excess energy generated by braking is returned to mains just a few seconds before opening contactor - KM1 thanks to the delayed deactivation of the relay - KA3. If for any reason the power bus voltage kept rising, the braking operation would be the same as that of the previous case.

**NOTE.** Remember that RPS power supplies do not have a Ballast circuit and if the application requires one, an off-the-shelf circuit will have to be used.

## Brake control

In some applications (e.g. the vertical Z axis on a milling machine) a electromechanical holding brake is used on the rotor of the motor.



**WARNING.** This brake must never be used to brake moving axes. It must only be used to hold or lock vertical axes that have been stopped previously !

Hence, the brake holds the rotor when loses voltage at its terminals. When the machine is out of service, the brake locks up the vertical Z axis to keep it from falling due to gravity.

**NOTE.** The reaction time of a brake integrated into an axis feeding FAGOR motor may vary between 7 ms and 97 ms depending on the model.



**MANDATORY.** While the brake is locking the vertical axis motor, the motor must be kept with torque. See parameter GP9 in chapter 13 of the "man\_dds\_soft.pdf" manual.



**MANDATORY.** When powering the machine up, the brake must never be released until the system assumes control of that axis. See the TV100 variable in chapter 13 of the "man\_dds\_soft.pdf" manual.

## Remember that

The control circuits of compact drives as well as RPS, XPS and PS-25B4 power supplies are powered at 24 V DC by an internal auxiliary power supply. PS-65A power supplies will need an external APS-24 auxiliary power supply to power them because they do not have one integrated into them.

In compact drives and power supplies, the auxiliary power supply must be powered at **single-phase** 400-460 V AC. But not RPS power supplies; they must be powered at **three-phase** 400-460 V AC.

Closing the main power switch - S1 must take two phases to connector X1 when using compact drives or an APS-24 as auxiliary power supply of the PS-65A and to connector X3 when using XPS or PS-25B4 power supplies. In the case of RPS power supplies, there are three phases instead of two and they must go to connector X1.



**INFORMATION.** It is necessary to install external protection fuses in the power lines of the auxiliary power supply. They are internally integrated into the main power supply.

Opening of contactor - KM1 does not remove the supply of power to the auxiliary power supply in any case. But opening the main switch - S1 does and the 24 V DC are maintained until the stop takes place.

# 10.

CONNECTION DIAGRAMS  
Electrical cabinet. Diagrams

**FAGOR**

DDS  
HARDWARE

Ref.1310

BLOCK DIAGRAM OF THE DDS SYSTEM START-UP WITH PS-XX POWER SUPPLIES

10.

CONNECTION DIAGRAMS  
Electrical cabinet. Diagrams



DDS  
HARDWARE

Ref.1310

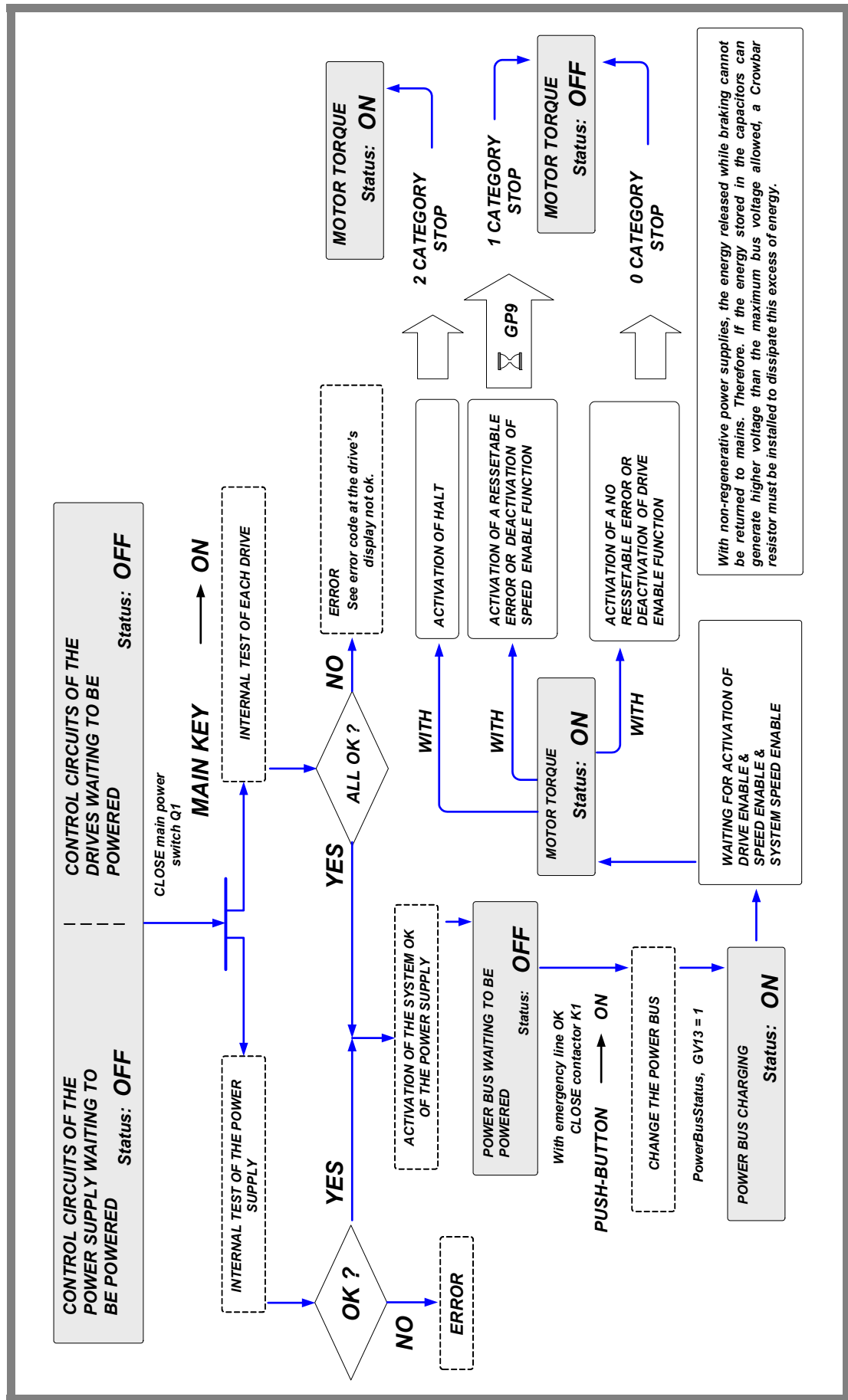

F. H10/7

Block diagram of the DDS system start-up with non-regenerative power supplies.

BLOCK DIAGRAM OF THE DDS SYSTEM START-UP WITH XPS AND RPS POWER SUPPLIES

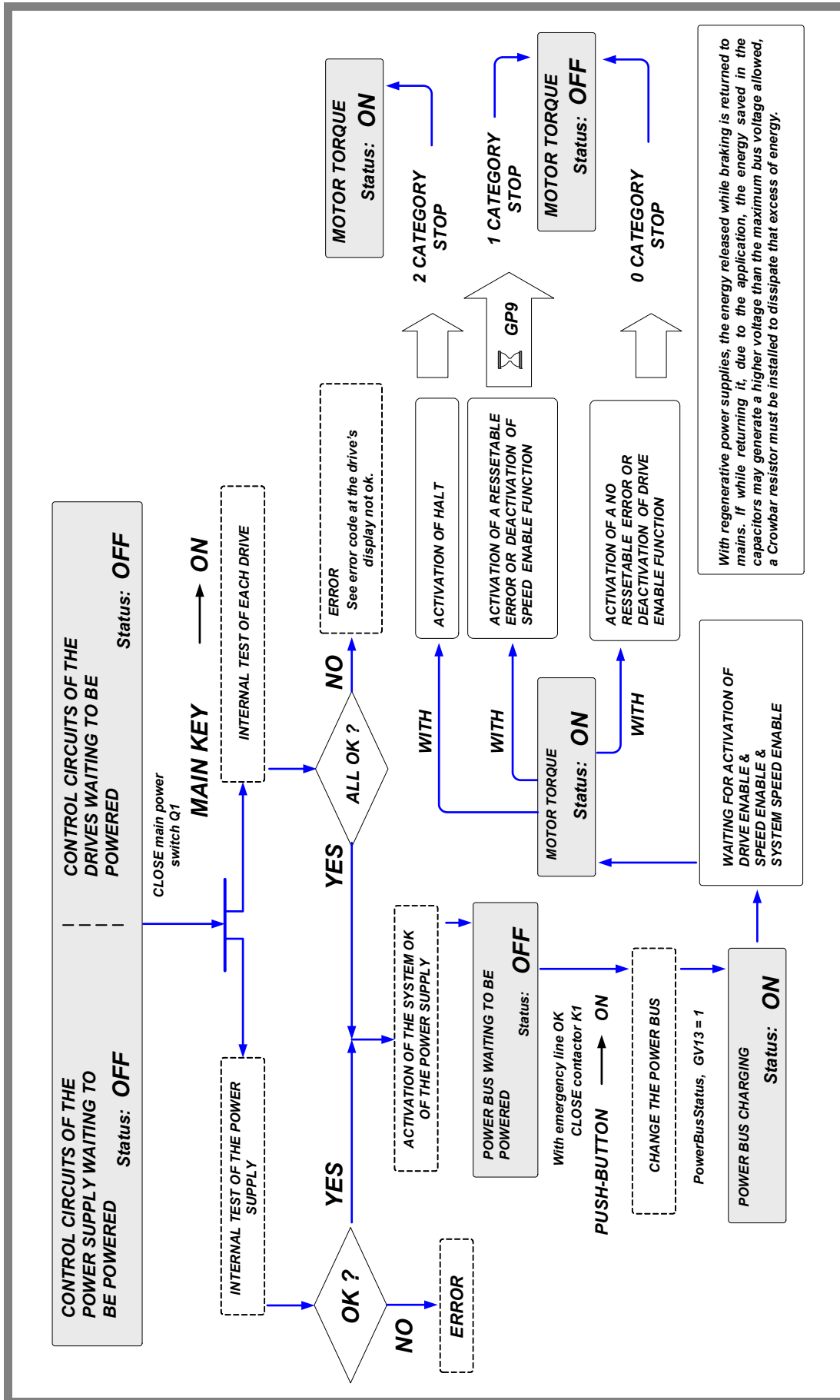

F. H10/8

Block diagram of the DDS system start-up with regenerative power supplies.

10.

CONNECTION DIAGRAMS  
Electrical cabinet. Diagrams



DDS  
HARDWARE

Ref.1310

## 10.8 Diagrams with a PS-65A power supply

# 10.

CONNECTION DIAGRAMS  
Diagrams with a PS-65A power supply

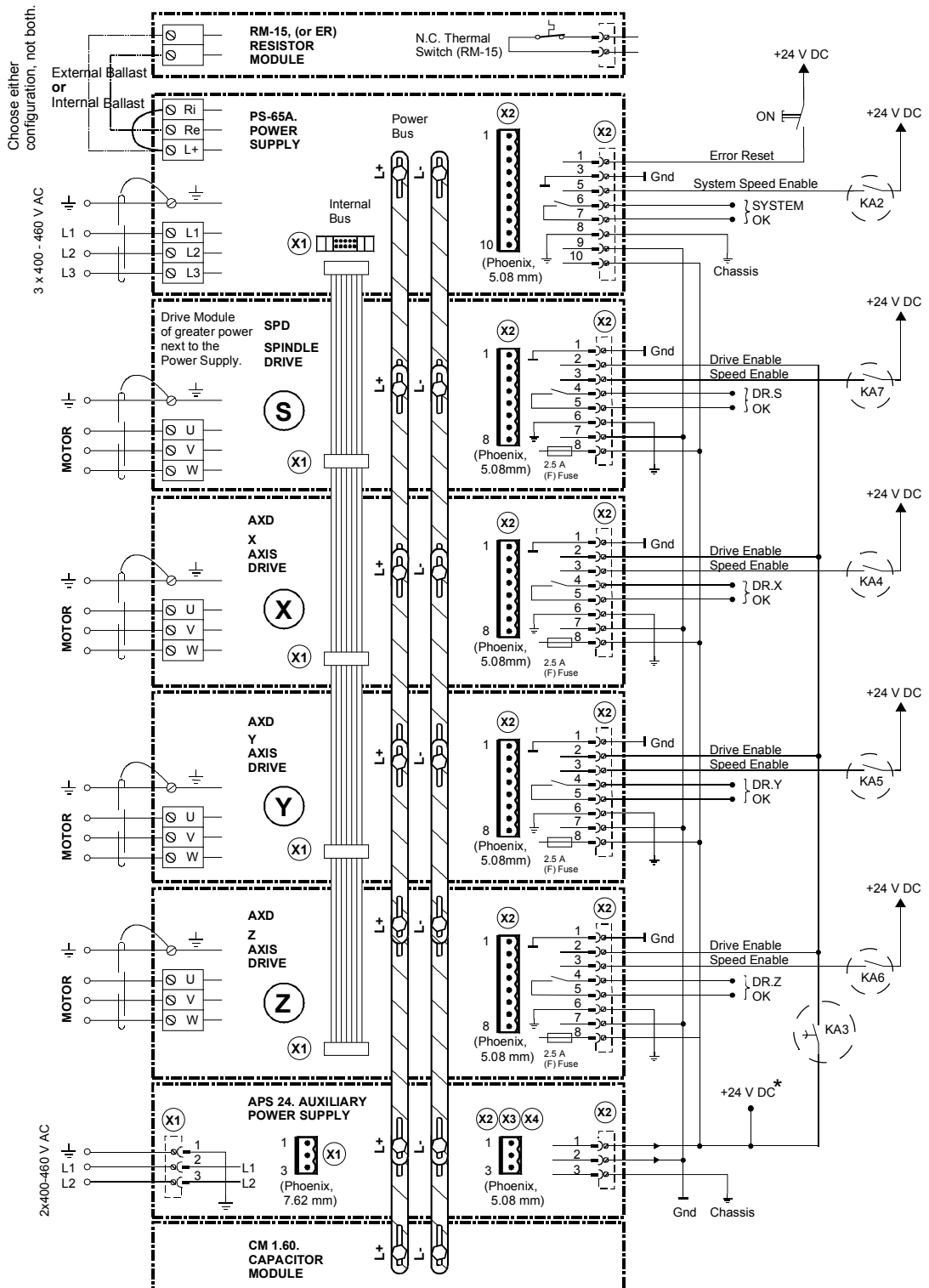

DDS  
HARDWARE

Ref.1310

F. H10/9

System with a PS-65A power supply.

**OPERATION DIAGRAM. PS-65A**

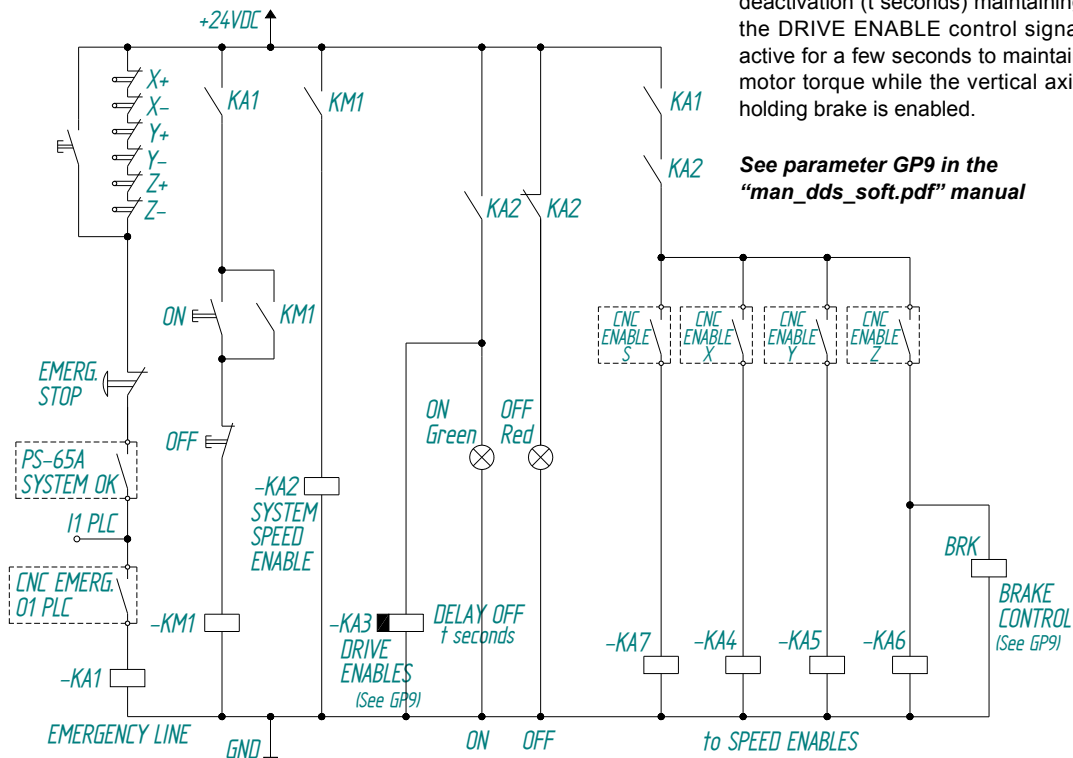

**Note.** The relay - KA3 uses delayed deactivation (t seconds) maintaining the DRIVE ENABLE control signal active for a few seconds to maintain motor torque while the vertical axis holding brake is enabled.

See parameter GP9 in the "man\_dds\_soft.pdf" manual

**10.**

CONNECTION DIAGRAMS  
Diagrams with a PS-65A power supply

**Note.** CNC EMERG. will always be assigned to I1/O1 of the PLC with an 8055/55i CNC. With an 8070 CNC, it may be assigned to any I/O of the PLC. The contacts associated with relays - KA2, - KA3, - KA4, - KA5, - KA6 and - KA7 are shown inside a circle in figure F. H10/9 and the contactor - KM1 in figure F. H10/11.

**F. H10/10**

System with a PS-65A power supply. Diagram of the maneuver.

**GENERAL DIAGRAM. PS-65A**

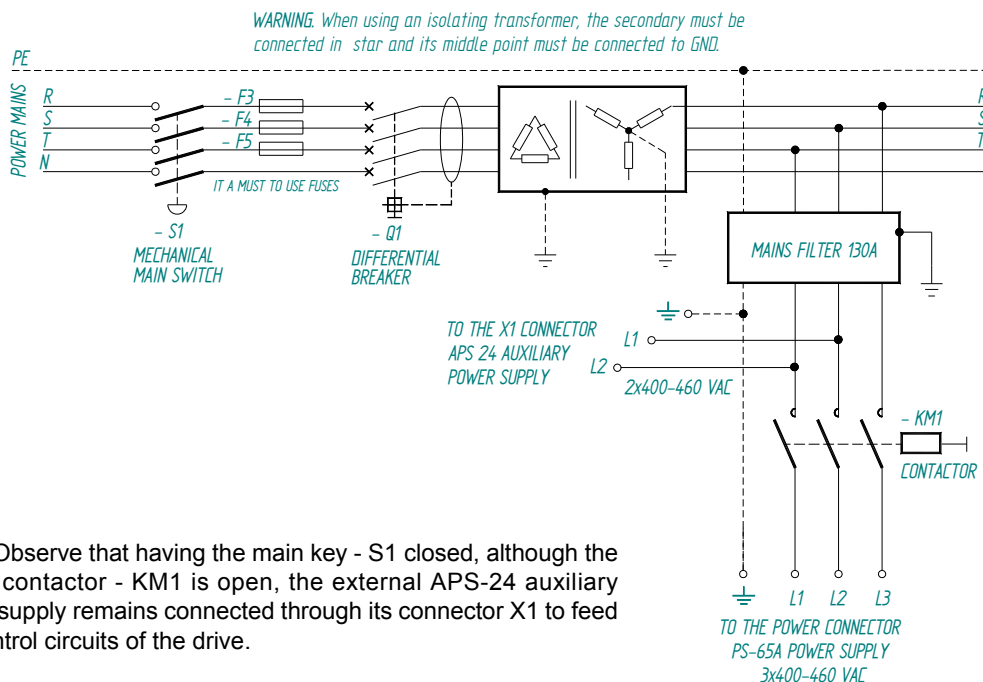

**Note.** Observe that having the main key - S1 closed, although the power contactor - KM1 is open, the external APS-24 auxiliary power supply remains connected through its connector X1 to feed the control circuits of the drive.

**F. H10/11**

General diagram of a DDS system with a PS-65A power supply.



DDS  
HARDWARE

Ref.1310

## 10.9 Diagrams with a PS-25B4 power supply

# 10.

CONNECTION DIAGRAMS  
Diagrams with a PS-25B4 power supply

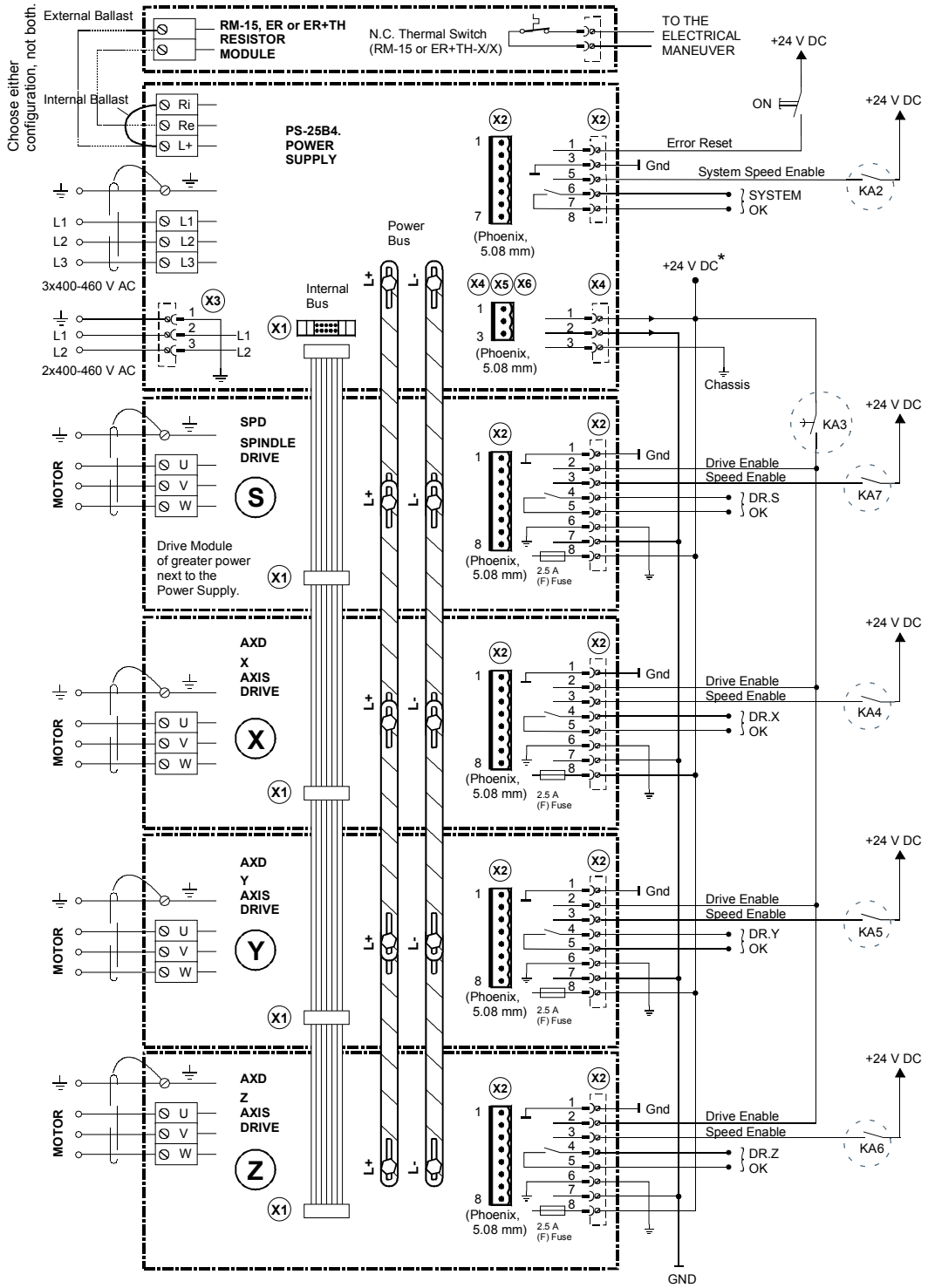

### F. H10/12

System with a PS-25B4 power supply



DDS  
HARDWARE

Ref.1310

**OPERATION DIAGRAM. PS-25B4**

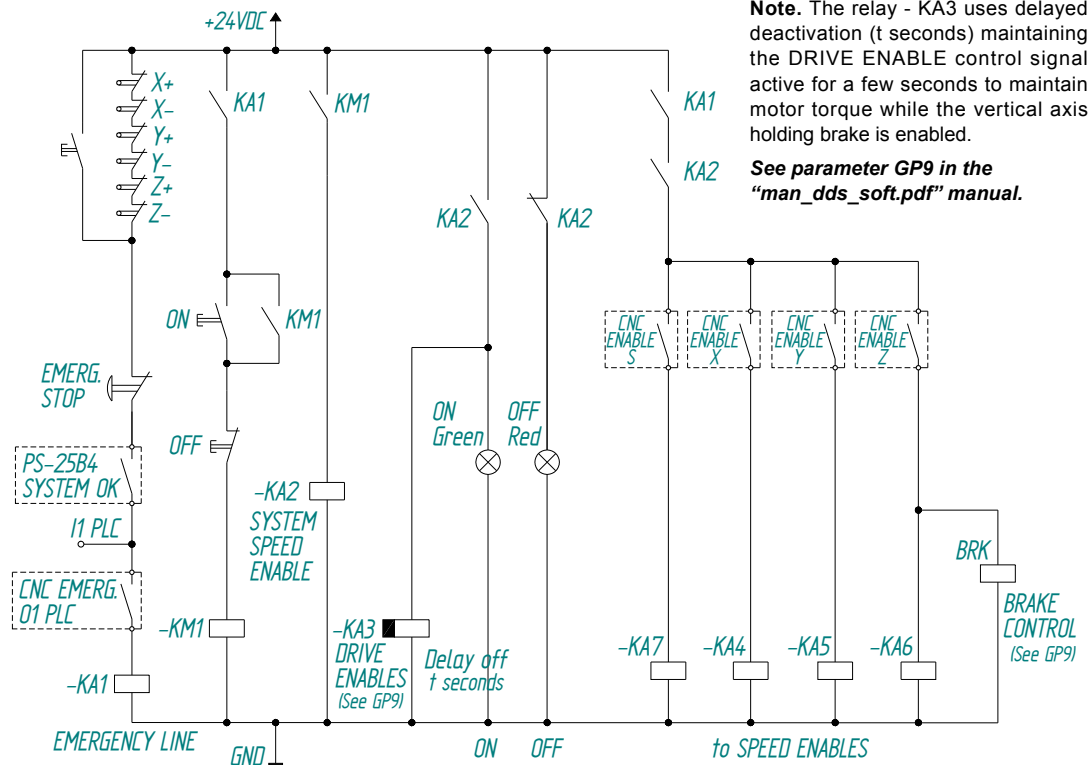

**Note.** CNC EMERG. will always be assigned to I1/O1 of the PLC with an 8055/55i CNC. With an 8070 CNC, it may be assigned to any I/O of the PLC. The contacts associated with relays - KA2, - KA3, - KA4, - KA5, - KA6 and - KA7 are shown inside a circle in figure F. H10/12 and the contactor - KM1 in figure F. H10/14.

**F. H10/13**

System with a PS-25B4 power supply Diagram of the maneuver.

**GENERAL DIAGRAM. PS-25B4**

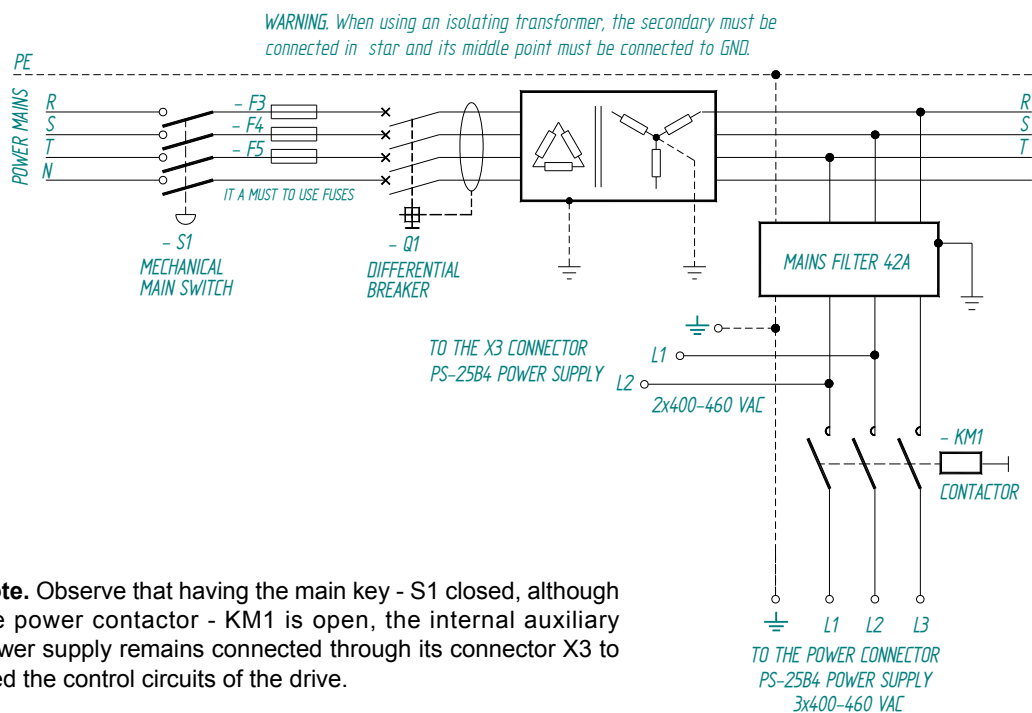

**F. H10/14**

General diagram of a DDS system with a PS-25B4 power supply.

**10.**

CONNECTION DIAGRAMS  
Diagrams with a PS-25B4 power supply



DDS  
HARDWARE

Ref.1310

### 10.10 Diagrams with a XPS power supply

# 10.

**CONNECTION DIAGRAMS**  
 Diagrams with a XPS power supply

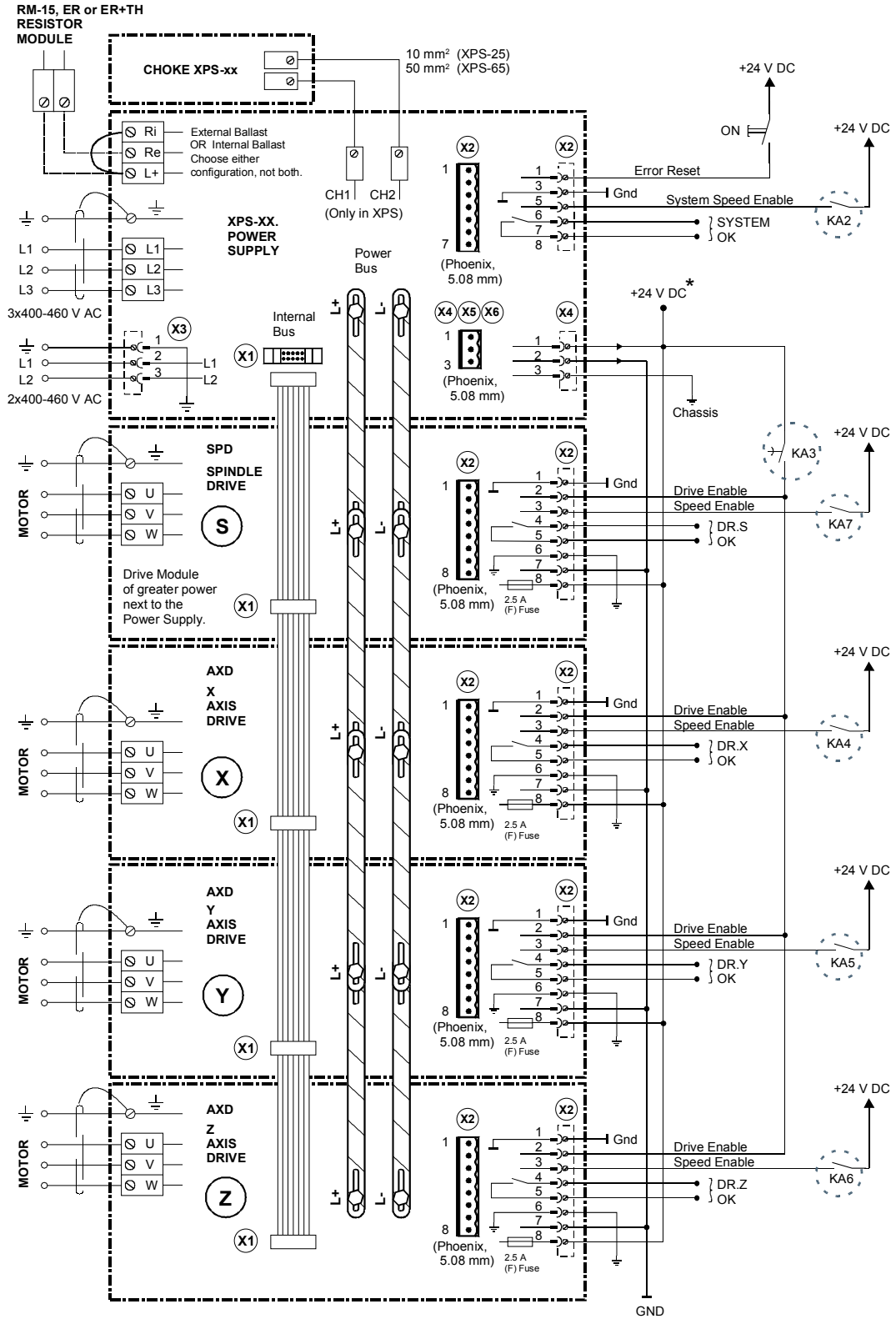

**DDS  
HARDWARE**

**F. H10/15**

System with a XPS power supply.

Ref.1310

**OPERATION DIAGRAM. XPS-XX**

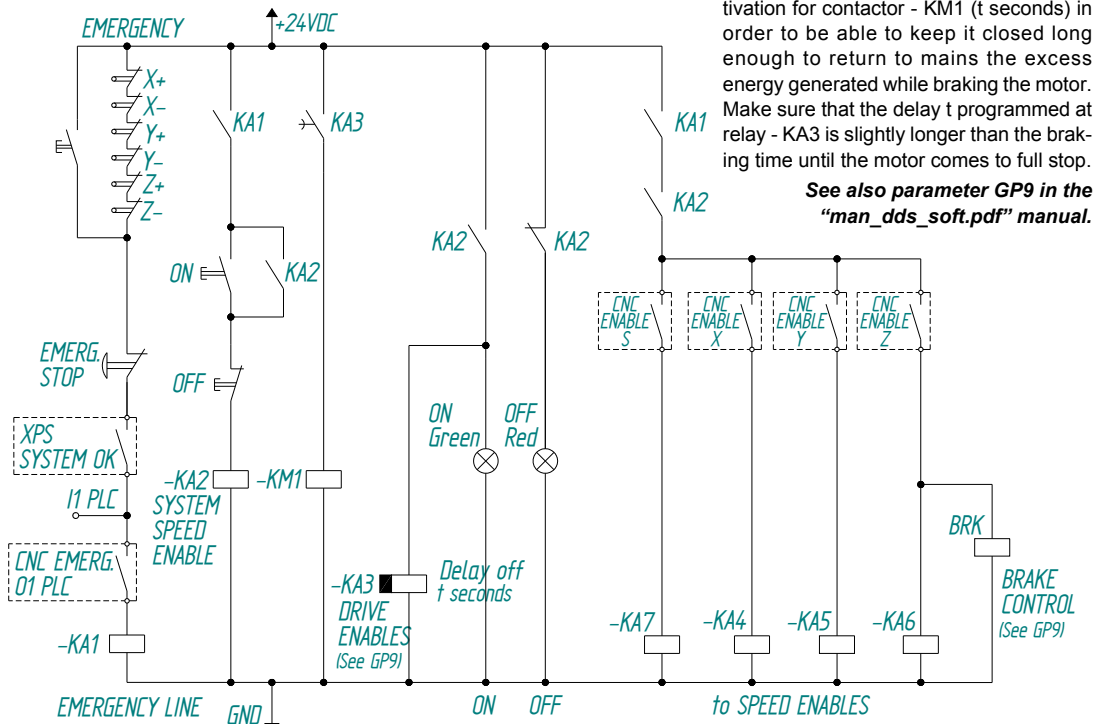

**Note.** The relay - KA3 uses delayed deactivation for contactor - KM1 (t seconds) in order to be able to keep it closed long enough to return to mains the excess energy generated while braking the motor. Make sure that the delay t programmed at relay - KA3 is slightly longer than the braking time until the motor comes to full stop.

See also parameter GP9 in the "man\_dds\_soft.pdf" manual.

10.

CONNECTION DIAGRAMS  
Diagrams with a XPS power supply

**Note.** CNC EMERG. will always be assigned to I1/O1 of the PLC with an 8055/55i CNC. With an 8070 CNC, it may be assigned to any I/O of the PLC. The contacts associated with relays - KA2, - KA3, - KA4, - KA5, - KA6 and - KA7 are shown inside a circle in figure F. H10/15 and the contactor - KM1 in figure F. H10/17.

**F. H10/16**

System with a XPS power supply. Diagram of the maneuver.

**GENERAL DIAGRAM. XPS-XX**

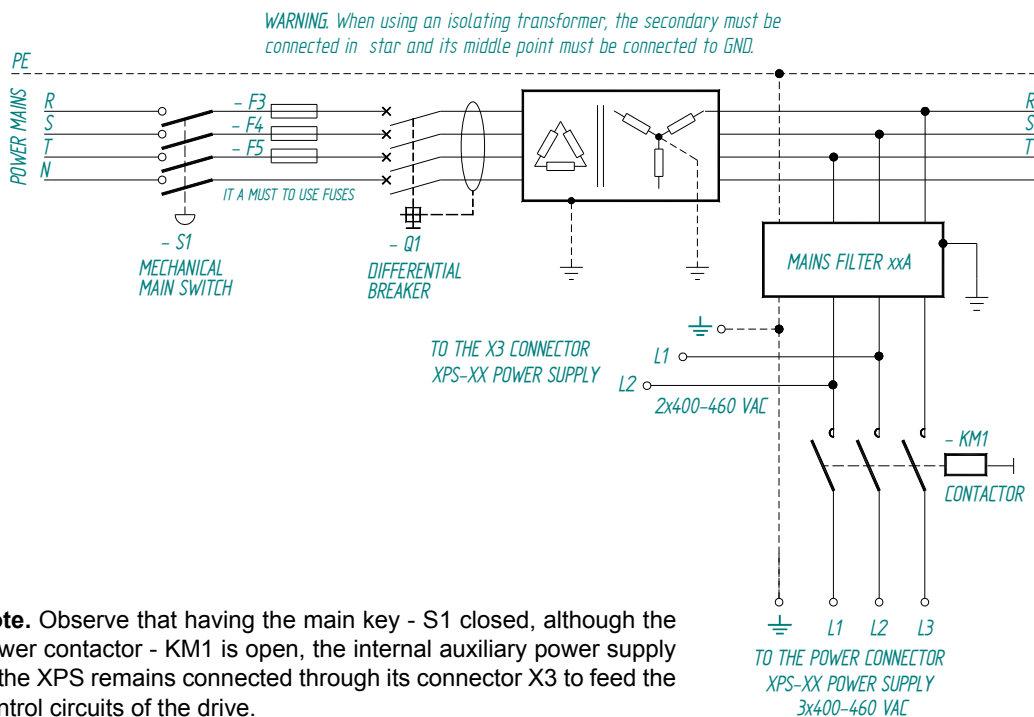

**Note.** Observe that having the main key - S1 closed, although the power contactor - KM1 is open, the internal auxiliary power supply of the XPS remains connected through its connector X3 to feed the control circuits of the drive.

**F. H10/17**

General diagram of a DDS system with a XPS power supply.



DDS  
HARDWARE

Ref.1310

## 10.11 Diagrams with an RPS-XX power supply

**IMPORTANT.** It is absolutely necessary to short-circuit pins NS1 and NS2 externally with a wire of at least 1 mm<sup>2</sup> section for the RPS to work.

# 10.

CONNECTION DIAGRAMS  
Diagrams with an RPS-XX power supply

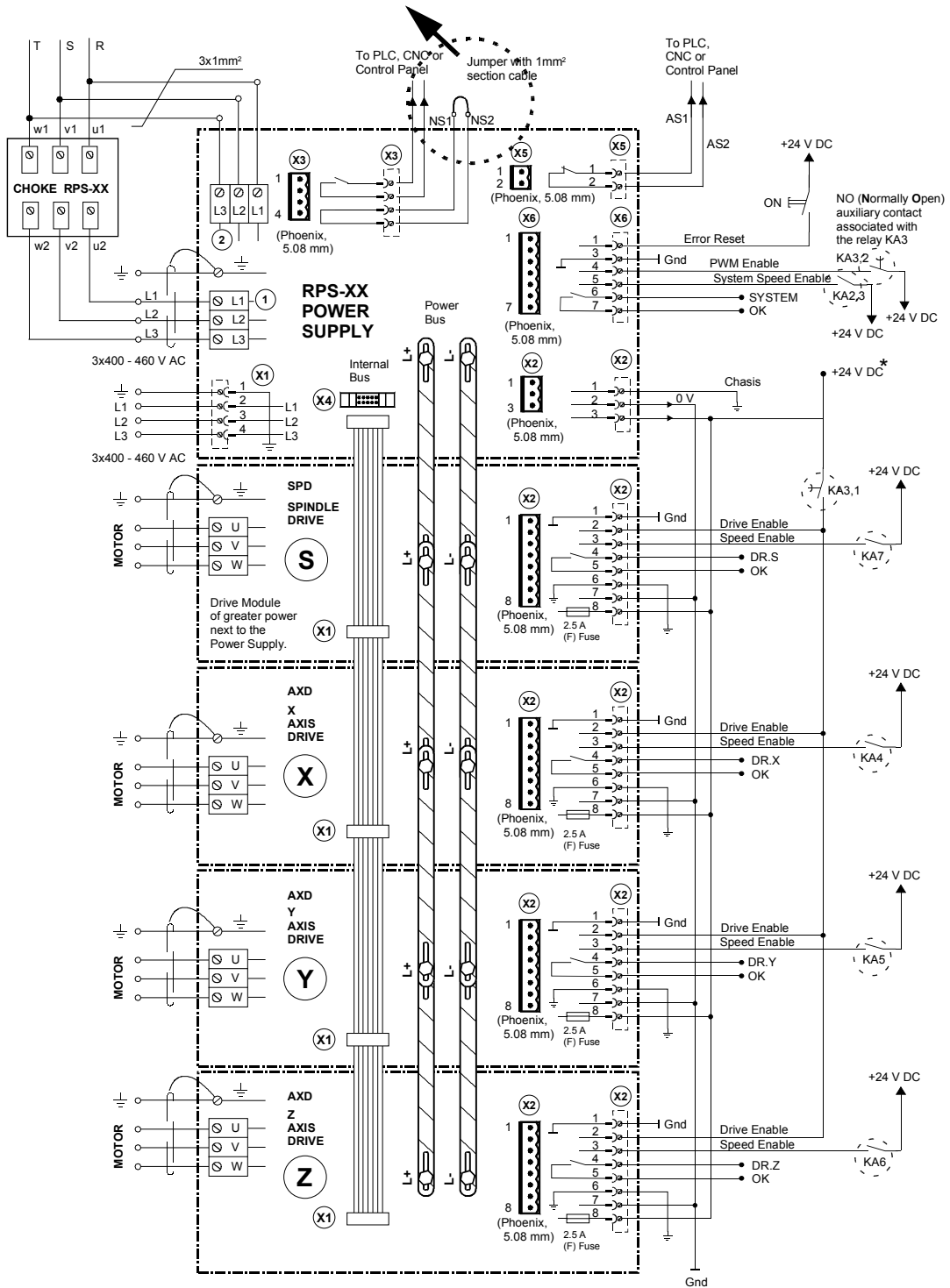

**Note 1.** The auxiliary contact KA3,2 associated with relay - KA3 appears in the diagrams of the next page. **Note 2.** An "SPD 3.250" drive must always be installed next to an RPS-80 power supply.

Ref.1310

F. H10/18

System with RPS power supply.



DDS  
HARDWARE

**OPERATION DIAGRAM. RPS-XX**

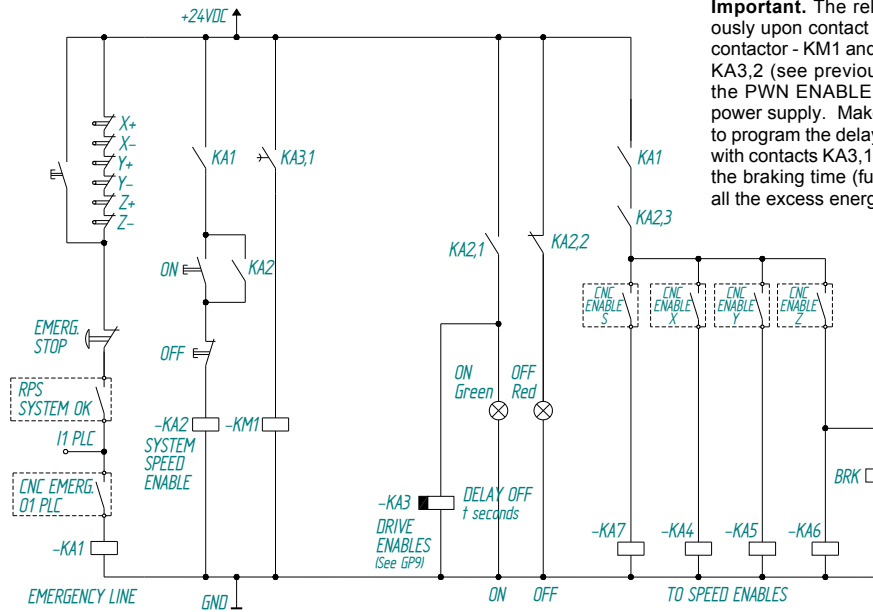

**Important.** The relay - KA3 acts simultaneously upon contact KA3,1 to excite the coil of contactor - KM1 and upon the auxiliary contact KA3,2 (see previous figure) associated with the PWN ENABLE (pin 4 of X6) of the RPS power supply. Make sure that the time t used to program the delay of relay - KA3 associated with contacts KA3,1 and KA3,2 is **greater** than the braking time (full stop) to permit returning all the excess energy to mains while braking.

The delay disconnection time "t" to be programmed at relay - KA3 must be **GREAT**ER THAN the total amount of time required to brake the motor to a full stop.

**Note.** CNC EMERG. will always be assigned to I1/O1 of the PLC with an 8055/55i CNC. With an 8070 CNC, it may be assigned to any I/O of the PLC. The contacts associated with relays - KA2, - KA3, - KA4, - KA5, - KA6 and - KA7 are shown inside a circle in figure **F. H10/18** and the contactor - KM1 in figure **F. H10/20**.

**F. H10/19**

System with RPS power supply. Diagram of the maneuver.

**GENERAL DIAGRAM. RPS-XX**

*WARNING. When using an isolating transformer, the secondary must be connected in star and its middle point must be connected to GND.*

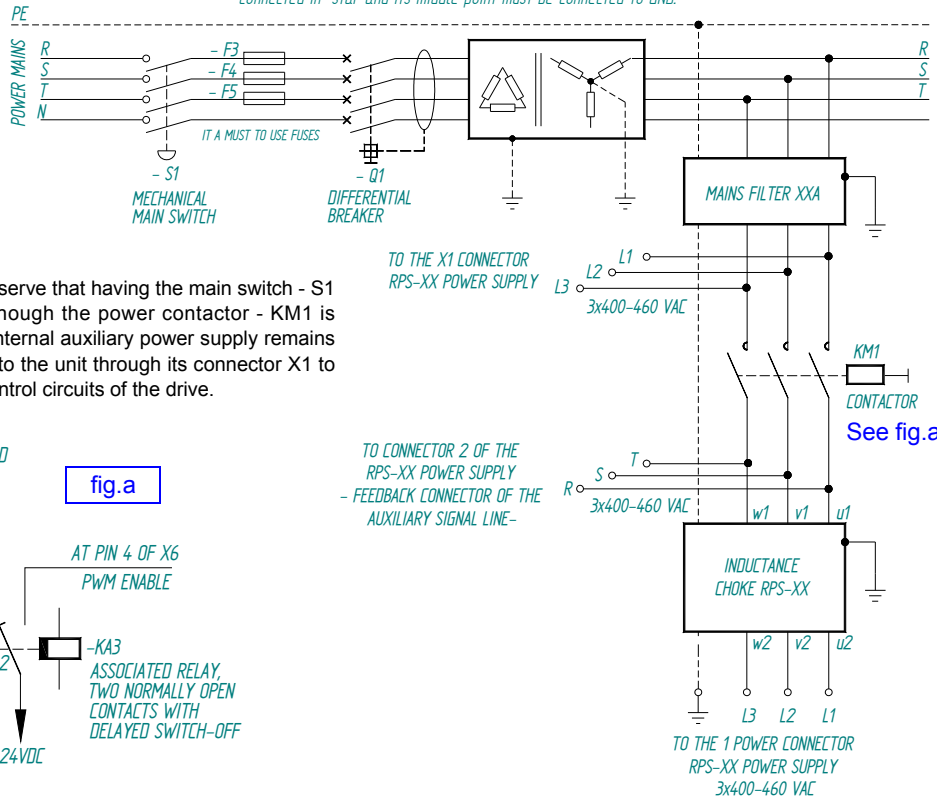

**Note 1.** Observe that having the main switch - S1 closed, although the power contactor - KM1 is open, the internal auxiliary power supply remains connected to the unit through its connector X1 to feed the control circuits of the drive.

**fig.a**

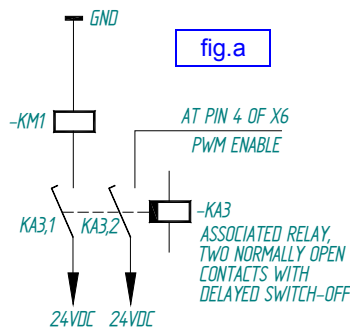

**F. H10/20**

System with RPS power supply. General diagram.

**10.**  
**CONNECTION DIAGRAMS**  
Diagrams with an RPS-XX power supply



**DDS  
HARDWARE**

**Ref.1310**

## 10.12 Compact system diagrams with SERCOS connection

# 10.

### CONNECTION DIAGRAMS

Compact system diagrams with SERCOS connection

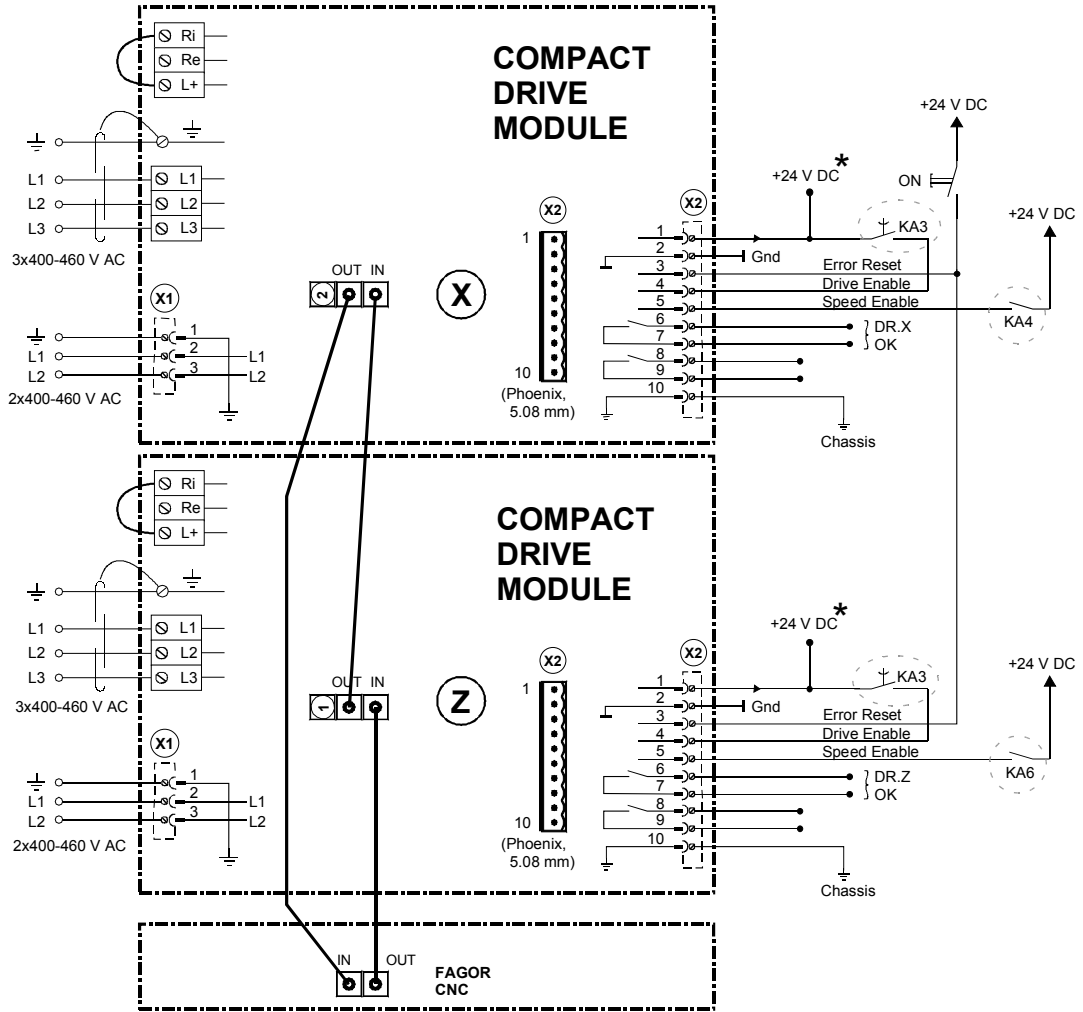

**Notes.** Compact modules do not have the System\_Speed\_Enable signals. In this diagram, in spite of having SERCOS interface, electrical signals are used to activate the enables.

### F. H10/21

Compact system with SERCOS connection.



DDS  
HARDWARE

Ref.1310

### 10.13 Compact system diagrams with CAN connection

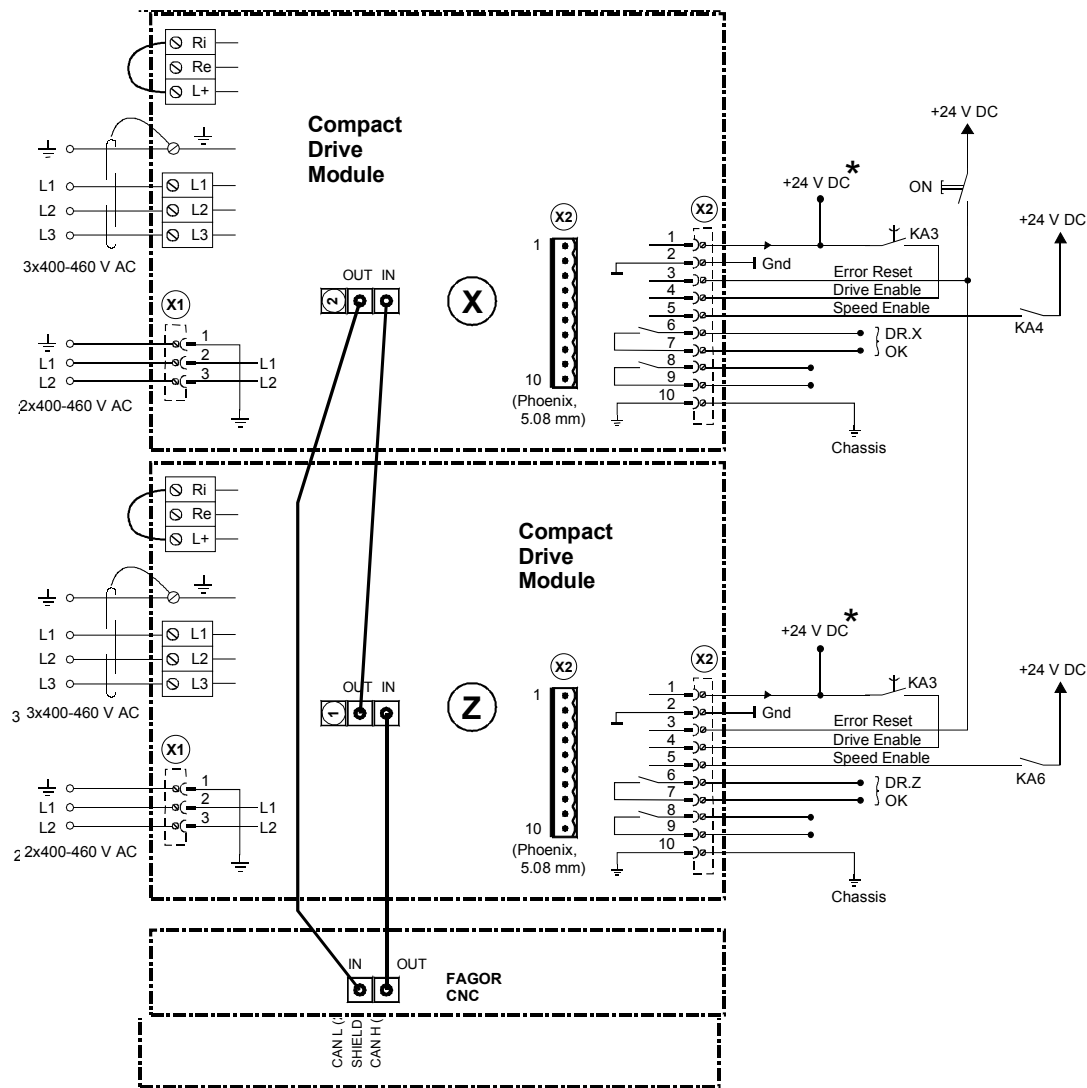

**Notes.** Compact modules do not have the System\_Speed\_Enable signals. In this diagram, in spite of having CAN interface, electrical signals are used to activate the enables.

**F. H10/22**

Compact system with CAN connection.

# 10.

CONNECTION DIAGRAMS  
Compact system diagrams with CAN connection



DDS  
HARDWARE

Ref.1310

**OPERATION DIAGRAM. ACD/SCD**

**Note 1.** The relay KA3 uses delayed deactivation (t seconds) maintaining the DRIVE ENABLE control signal active for a few seconds to maintain motor torque while the vertical axis holding brake is enabled. See parameter GP9 in the "man\_dds\_soft.pdf" manual.

**Note 2.** CNC EMERG. will always be assigned to I1/O1 of the PLC with an 8055/55i CNC. With an 8070 CNC, it may be assigned to any I/O of the PLC. The contacts associated with relays - KA3, - KA4 and - KA6 are shown inside a circle in figure F. H10/21 and the contactor - KM1 in figure F. H10/24.

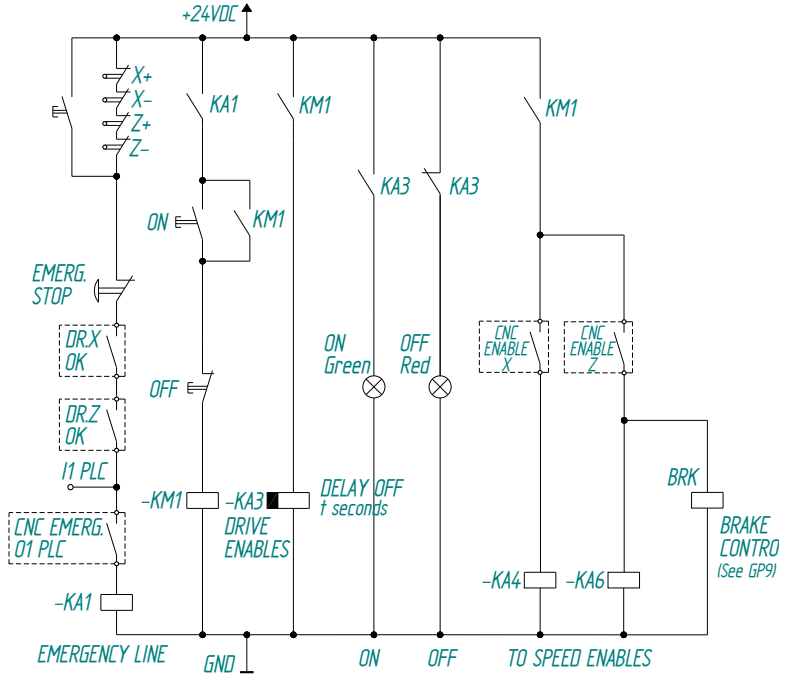

**F. H10/23**

Compact system with SERCOS or CAN connection. Diagram of the maneuver.

**GENERAL DIAGRAM. ACD/SCD**

*WARNING. When using an isolating transformer, the secondary must be connected in star and its middle point must be connected to GND.*

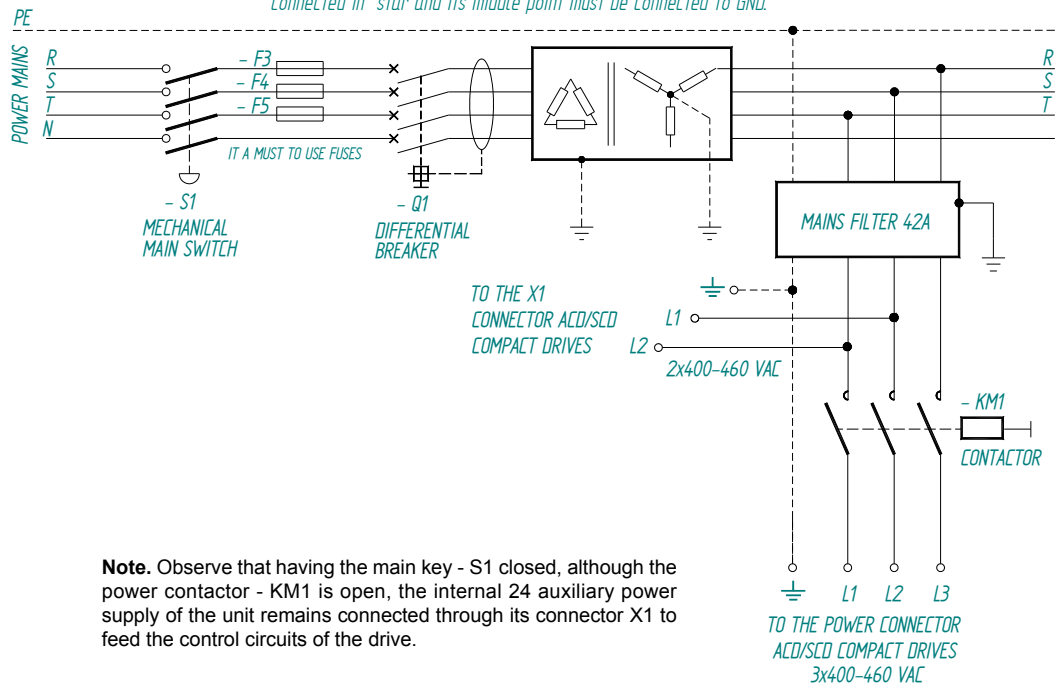

**Note.** Observe that having the main key - S1 closed, although the power contactor - KM1 is open, the internal 24 auxiliary power supply of the unit remains connected through its connector X1 to feed the control circuits of the drive.

**F. H10/24**

General diagram of a compact DDS system with SERCOS or CAN connection.

10.

CONNECTION DIAGRAMS  
Compact system diagrams with CAN connection



DDS  
HARDWARE

Ref.1310

### 10.14 Diagrams of a mixed (combined) system with SERCOS connection

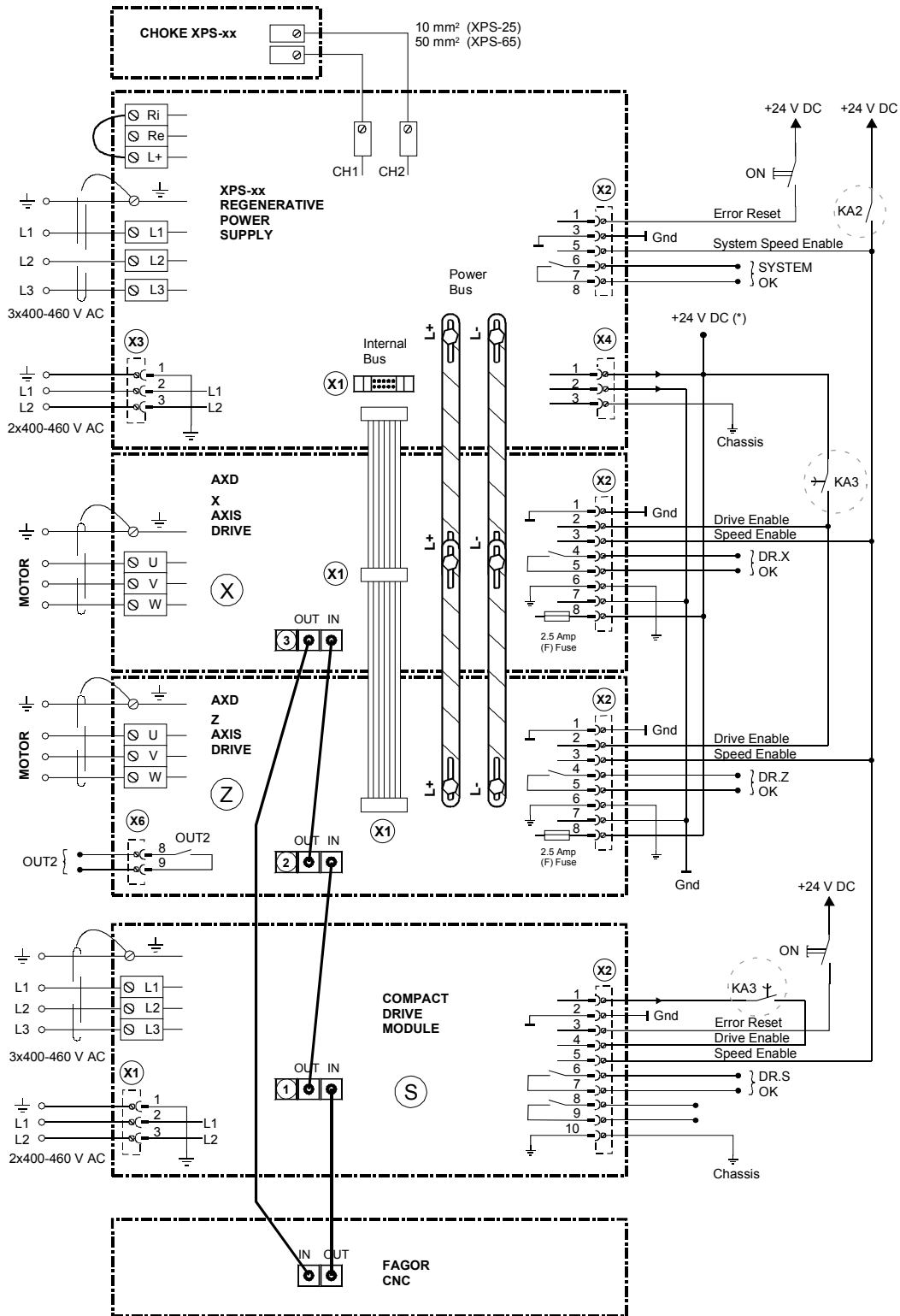

# 10.

CONNECTION DIAGRAMS  
Diagrams of a mixed (combined) system with SERCOS connection



DDS  
HARDWARE

F. H10/25

Mixed system with SERCOS connection.

Ref.1310

### 10.15 Diagrams of a mixed (combined) system with CAN connection

# 10.

**CONNECTION DIAGRAMS**

Diagrams of a mixed (combined) system with CAN connection

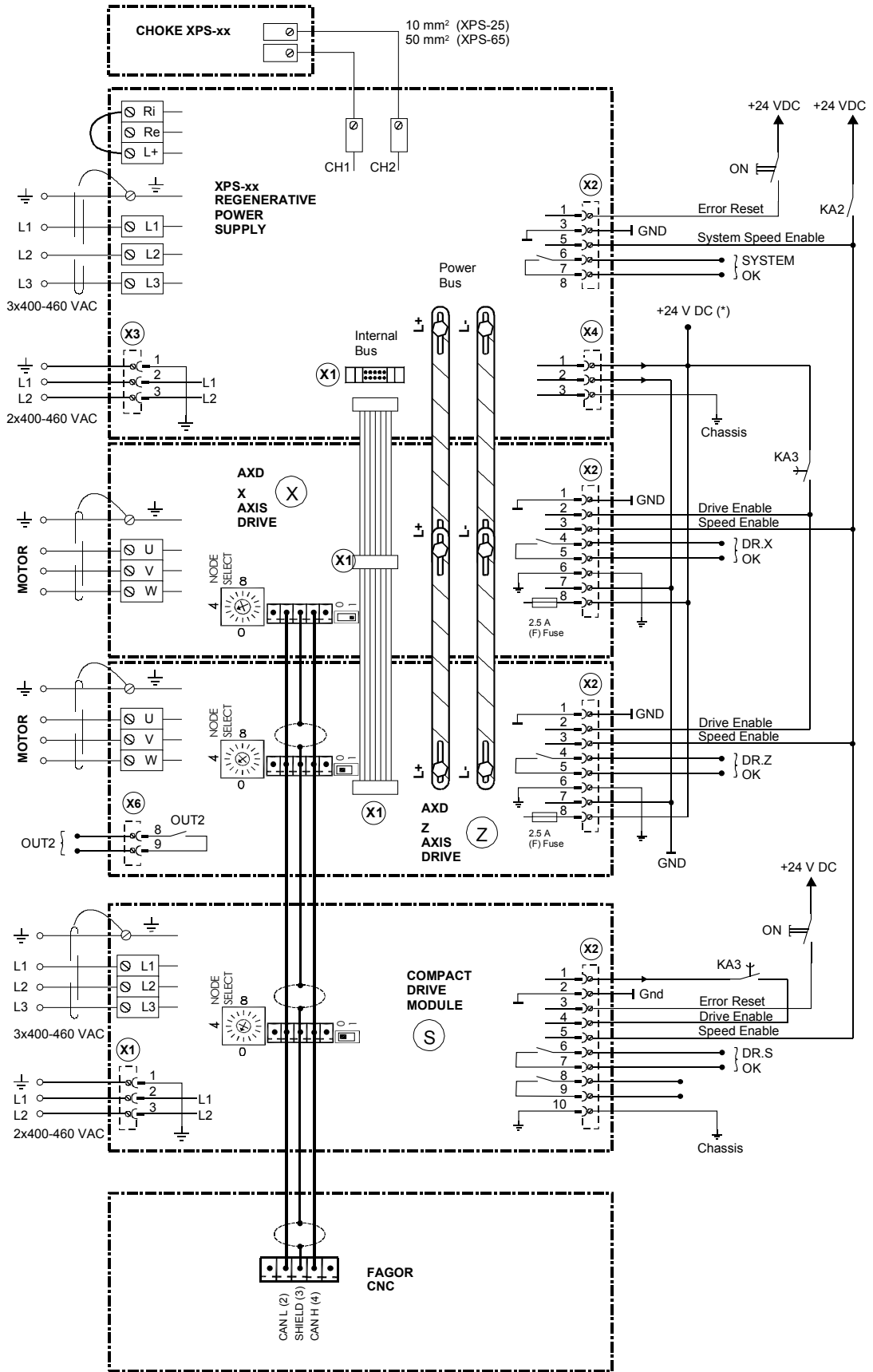

DDS  
HARDWARE

**F. H10/26**

Mixed system with CAN connection.

Ref.1310

**OPERATION DIAGRAM**

**Note 1.** - KA3 is a relay for a delayed deactivation of contactor - KM1 (t seconds) in order to be able to keep it closed long enough to return to mains (with XPS power supply) the excess energy generated while braking the motor.

Make sure that the delay "t" programmed at relay - KA3 is slightly longer than the braking time of the application.

The delay disconnection time "t" to be programmed at relay - KA3 must be **greater than** the total amount of time required to brake the motor to a full stop.

See parameter GP9 in the "man\_dds\_soft.pdf" manual.

**Note 2.** CNC EMERG. will always be assigned to I1/O1 of the PLC with an 8055/55i CNC. With an 8070 CNC, it may be assigned to any I/O of the PLC.

The contacts associated with relays - KA2 and - KA3 are shown inside a circle in figure F. H10/25.

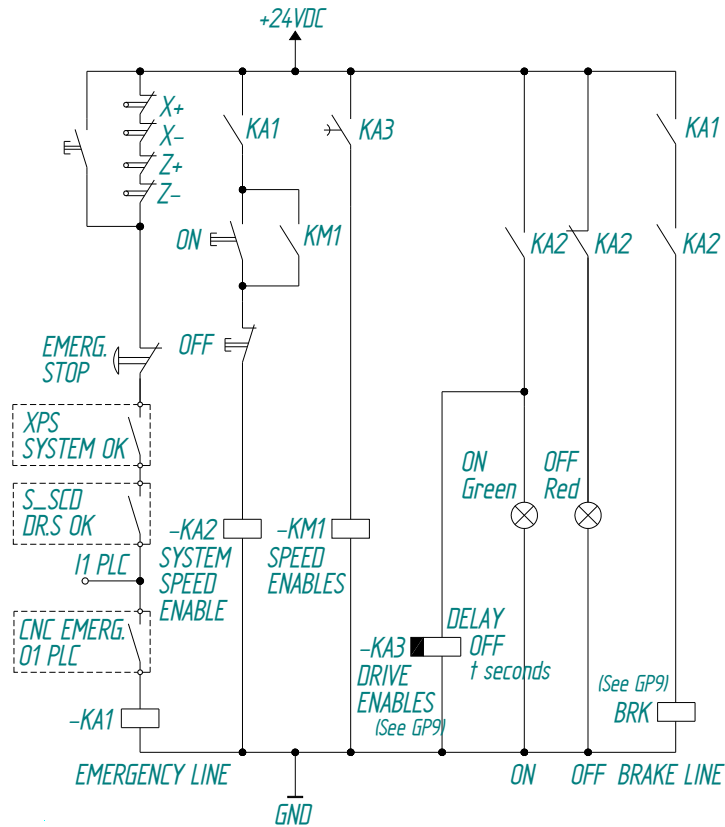

**F. H10/27**

Mixed system with SERCOS or CAN connection. Diagram of the maneuver.

**10.**

CONNECTION DIAGRAMS  
Diagrams of a mixed (combined) system with CAN connection



DDS  
HARDWARE

Ref.1310

### 10.16 Brake connection diagram for synchronous axis servo motors

# 10.

**CONNECTION DIAGRAMS**

Brake connection diagram for synchronous axis servo motors

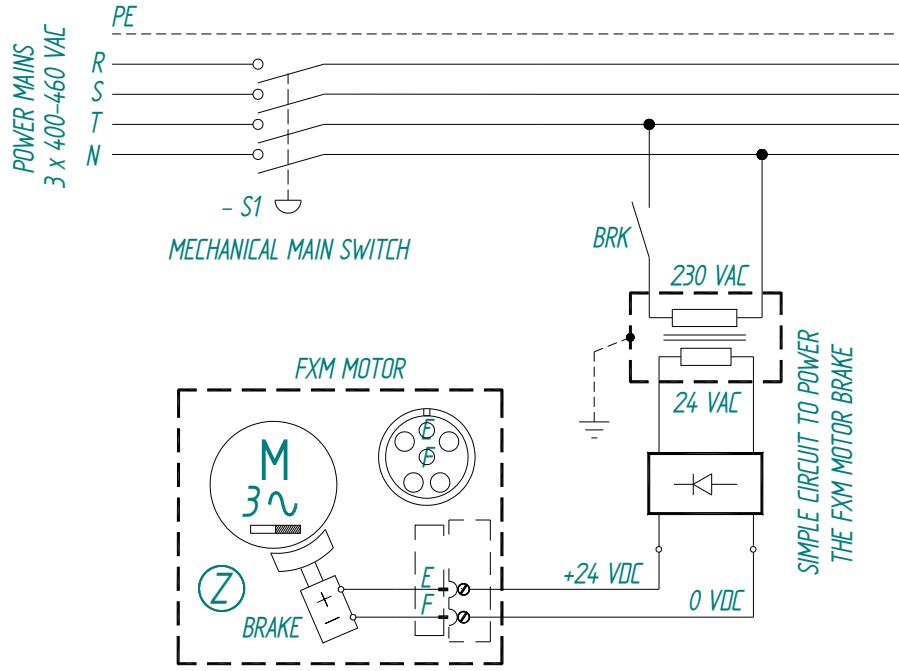

**F. H10/28**

Connection diagram for the brake of an FXM synchronous servo motor.

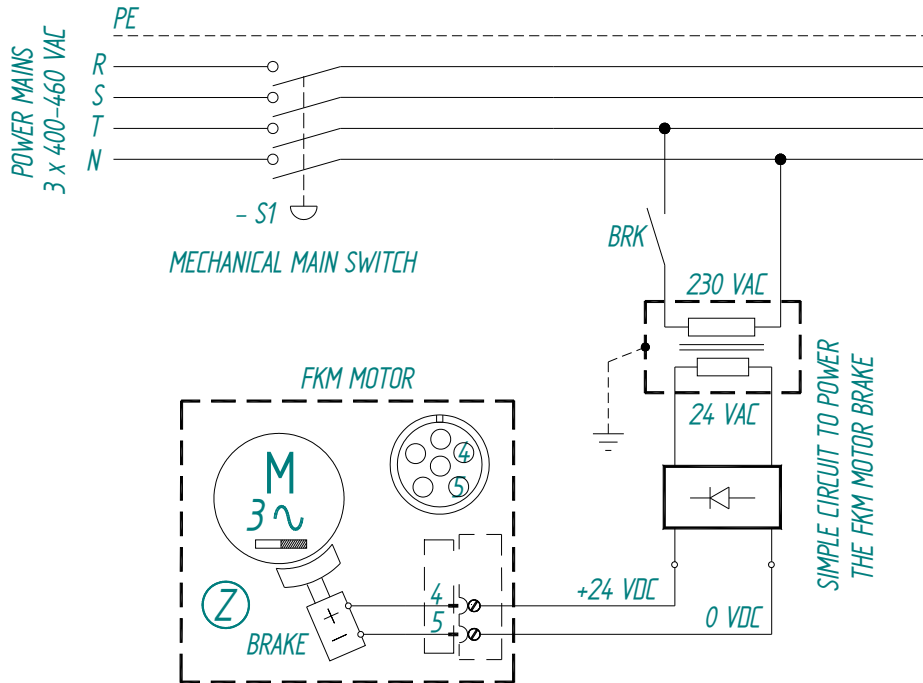

**F. H10/29**

Connection diagram for the brake of an FKM synchronous servo motor.



DDS  
HARDWARE

Ref.1310

### 10.17 On-the-fly start/delta connection switching on FM7 spindles, E03 & HS3 series

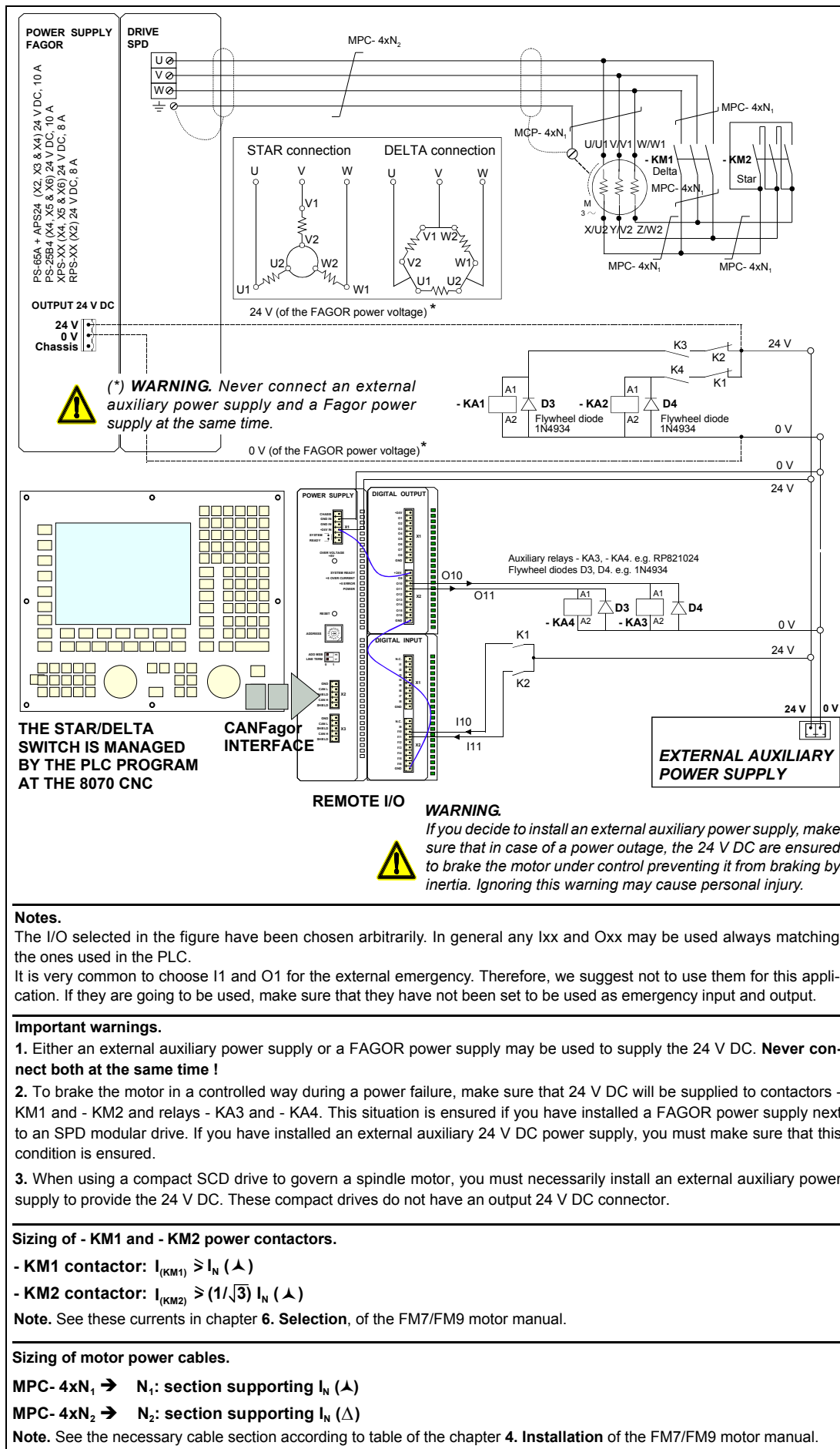

10.

CONNECTION DIAGRAMS  
 On-the-fly start/delta connection switching on FM7 spindles, E03 & HS3 series

**Notes.**

The I/O selected in the figure have been chosen arbitrarily. In general any Ixx and Oxx may be used always matching the ones used in the PLC.

It is very common to choose I1 and O1 for the external emergency. Therefore, we suggest not to use them for this application. If they are going to be used, make sure that they have not been set to be used as emergency input and output.

**Important warnings.**

1. Either an external auxiliary power supply or a FAGOR power supply may be used to supply the 24 V DC. **Never connect both at the same time !**
2. To brake the motor in a controlled way during a power failure, make sure that 24 V DC will be supplied to contactors - KM1 and - KM2 and relays - KA3 and - KA4. This situation is ensured if you have installed a FAGOR power supply next to an SPD modular drive. If you have installed an external auxiliary 24 V DC power supply, you must make sure that this condition is ensured.
3. When using a compact SCD drive to govern a spindle motor, you must necessarily install an external auxiliary power supply to provide the 24 V DC. These compact drives do not have an output 24 V DC connector.

**Sizing of - KM1 and - KM2 power contactors.**

- KM1 contactor:  $I_{(KM1)} \geq I_N (\Delta)$

- KM2 contactor:  $I_{(KM2)} \geq (1/\sqrt{3}) I_N (\Delta)$

**Note.** See these currents in chapter 6. Selection, of the FM7/FM9 motor manual.

**Sizing of motor power cables.**

MPC- 4xN<sub>1</sub> → N<sub>1</sub>: section supporting I<sub>N</sub> (Δ)

MPC- 4xN<sub>2</sub> → N<sub>2</sub>: section supporting I<sub>N</sub> (Δ)

**Note.** See the necessary cable section according to table of the chapter 4. Installation of the FM7/FM9 motor manual.

**F. H10/30**

Diagram of on-the-fly Y/D (start/delta) connection switching for FM7-XXXX-XXX-E03/HS3 motors.



DDS  
 HARDWARE

Ref.1310

# 10.

CONNECTION DIAGRAMS



DDS  
HARDWARE

Ref.1310

# DIMENSIONS



When designing and building the electrical cabinet, it is crucial to consider the necessary space to include the modules that will make up the DDS system, auxiliary modules and other elements such as cables and connectors.

## 11.1 Main modules

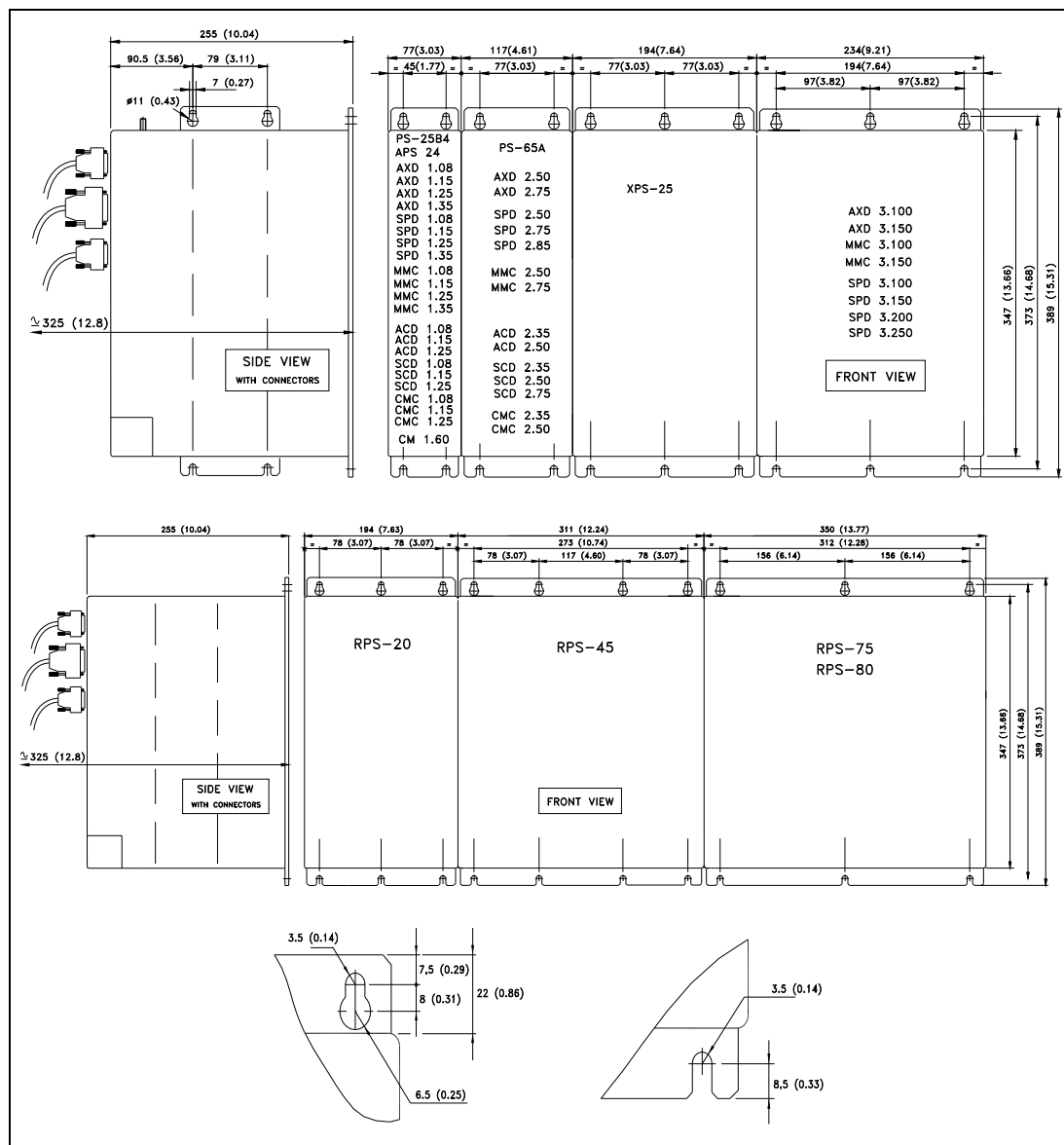

### F. H11/1

Dimensions of the main modules.

**NOTE.** Remember that the upper power connectors may need a height of up to 45 mm.



DDS  
HARDWARE

Ref.1310

## 11.2 Power supply modules

# 11.

### DIMENSIONS

Power supply modules

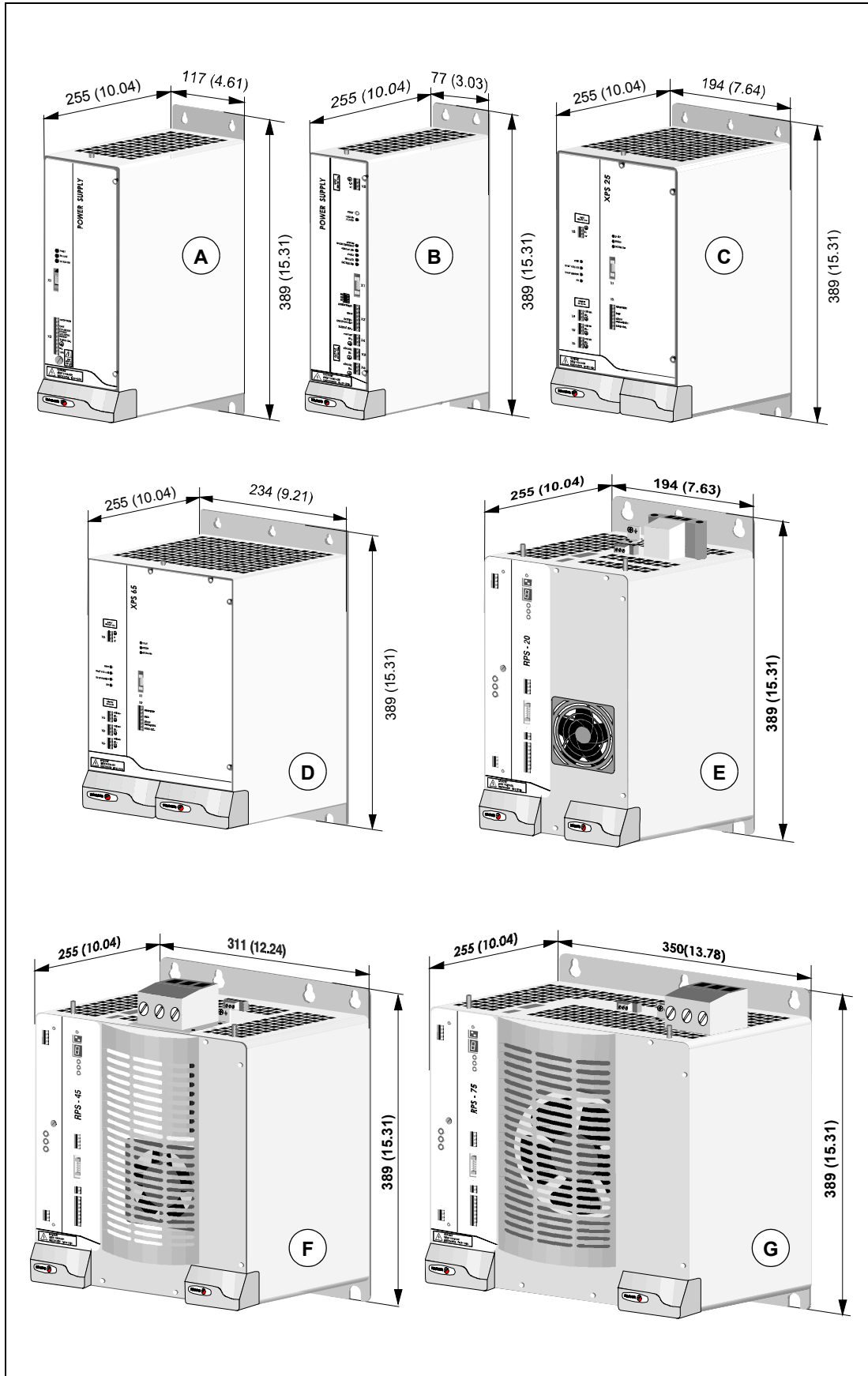

### F. H11/2

Dimensions of the power supplies.

A. PS-65A, B. PS-25B4, C. XPS-25, D. XPS-65, E. RPS-20, F. RPS-45, G. RPS-75/80.



DDS  
HARDWARE

Ref.1310

### 11.3 Modular drive modules

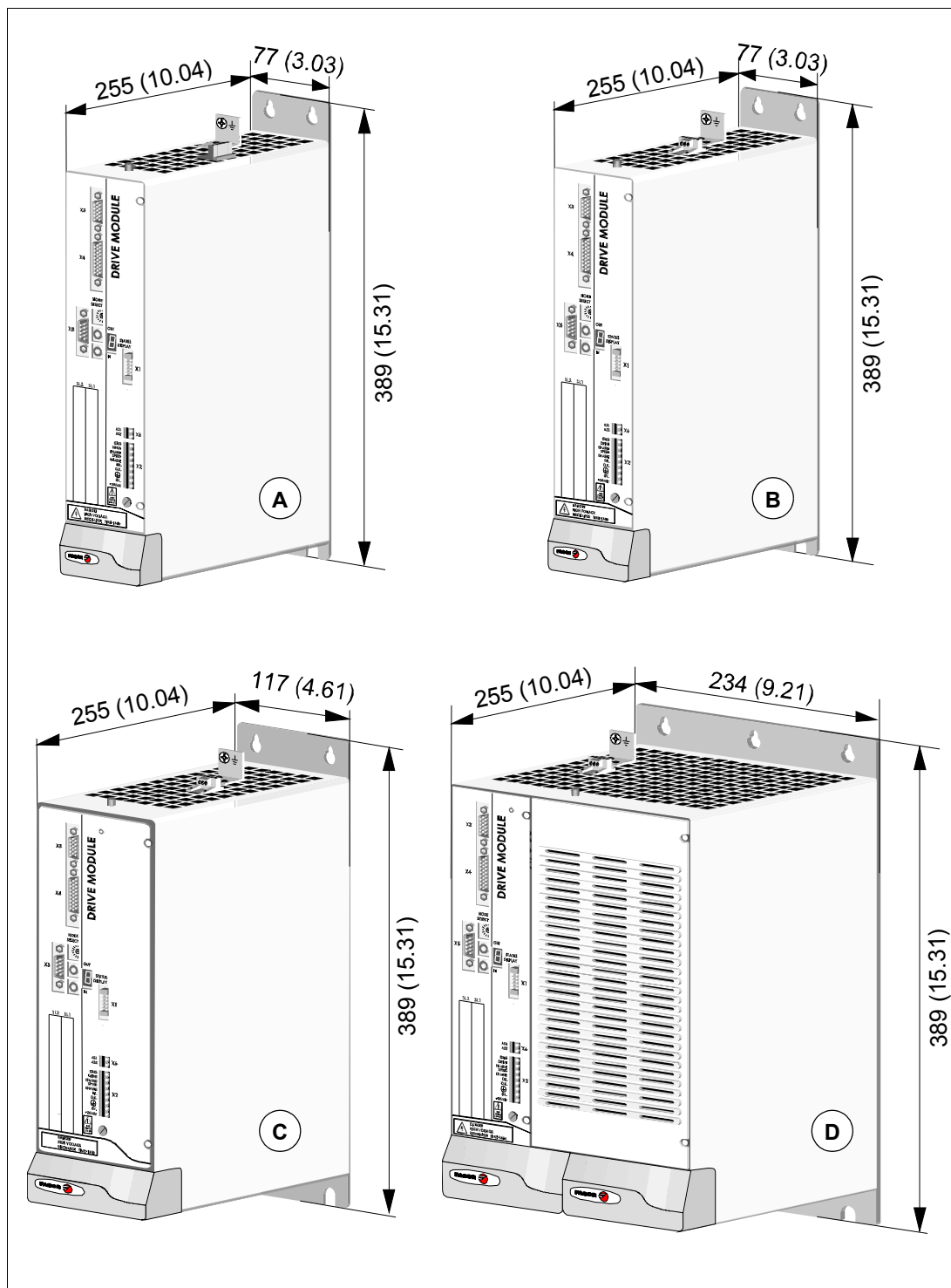

**F. H11/3**

Dimensions of the modular drives.

**A.** AXD/SPD 1.08/1.15, **B.** AXD/SPD 1.25/1.35, **C.** AXD/SPD 2.□□, **D.** AXD/SPD 3.□□.

# 11.

**DIMENSIONS**  
Modular drive modules



**DDS  
HARDWARE**

Ref.1310

## 11.4 Compact drive modules

# 11.

**DIMENSIONS**  
Compact drive modules

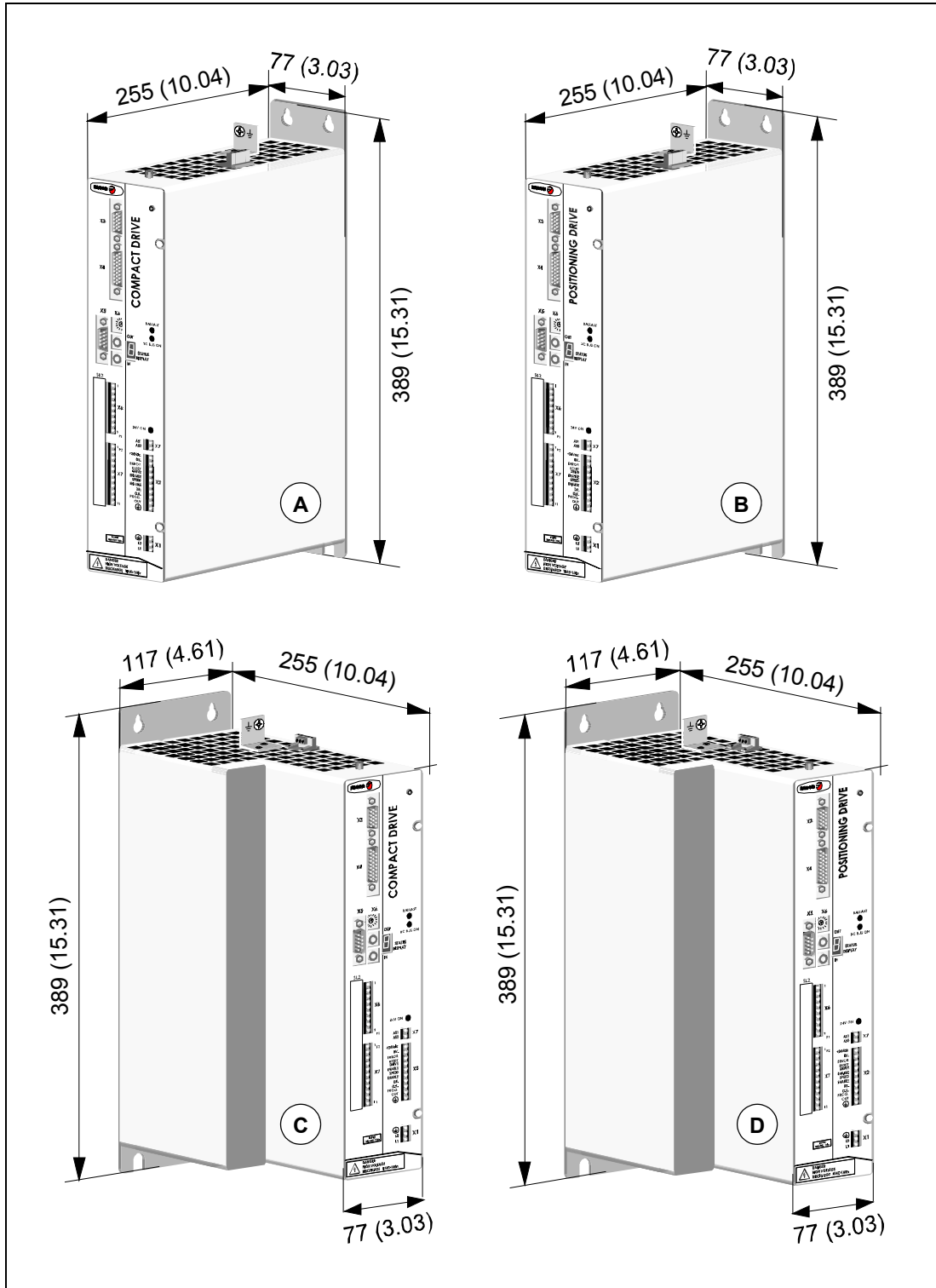

F. H11/4

Dimensions of the compact drives.

A. ACD/SCD 1.□□, B. CMC 1.□□, C. ACD/SCD 2.□□, D. CMC 2.□□.



DDS  
HARDWARE

Ref.1310

## 11.5 Mains filter

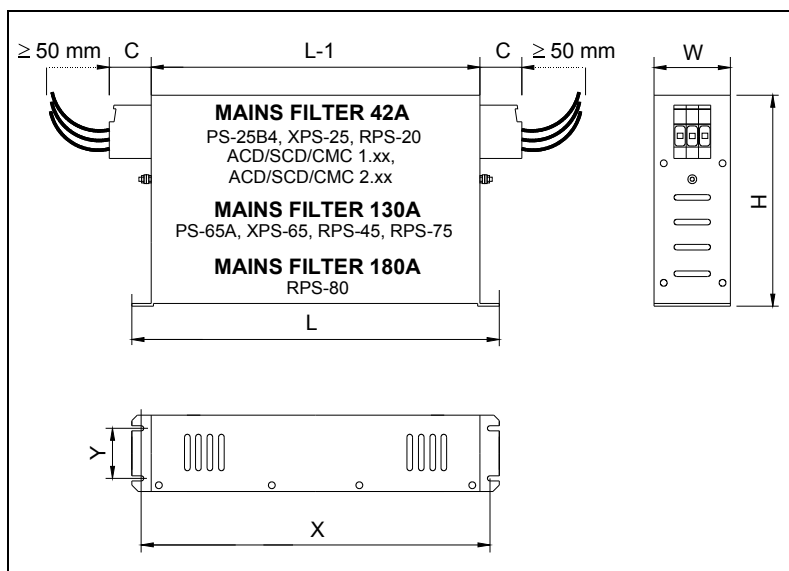

### F. H11/5

MAINS FILTER □□A.

### T. H11/1 Dimensions.

MAINS FILTER	42A		130A		180A	
	mm	inches	mm	inches	mm	inches
Units						
<b>L</b>	330	12.99	440	17.32	440	17.32
<b>L-1</b>	300	11.81	400	15.74	400	15.74
<b>C</b>	15	0.59	45	1.77	45	1.77
<b>W</b>	70	2.75	110	4.33	110	4.33
<b>H</b>	185	7.28	240	9.44	240	9.44
<b>X</b>	314	12.36	414	16.29	414	16.29
<b>Y</b>	45	1.77	80	3.14	80	3.14

# 11.

**DIMENSIONS**  
Mains filter

## 11.6 XPS chokes

# 11.

**DIMENSIONS**  
XPS chokes

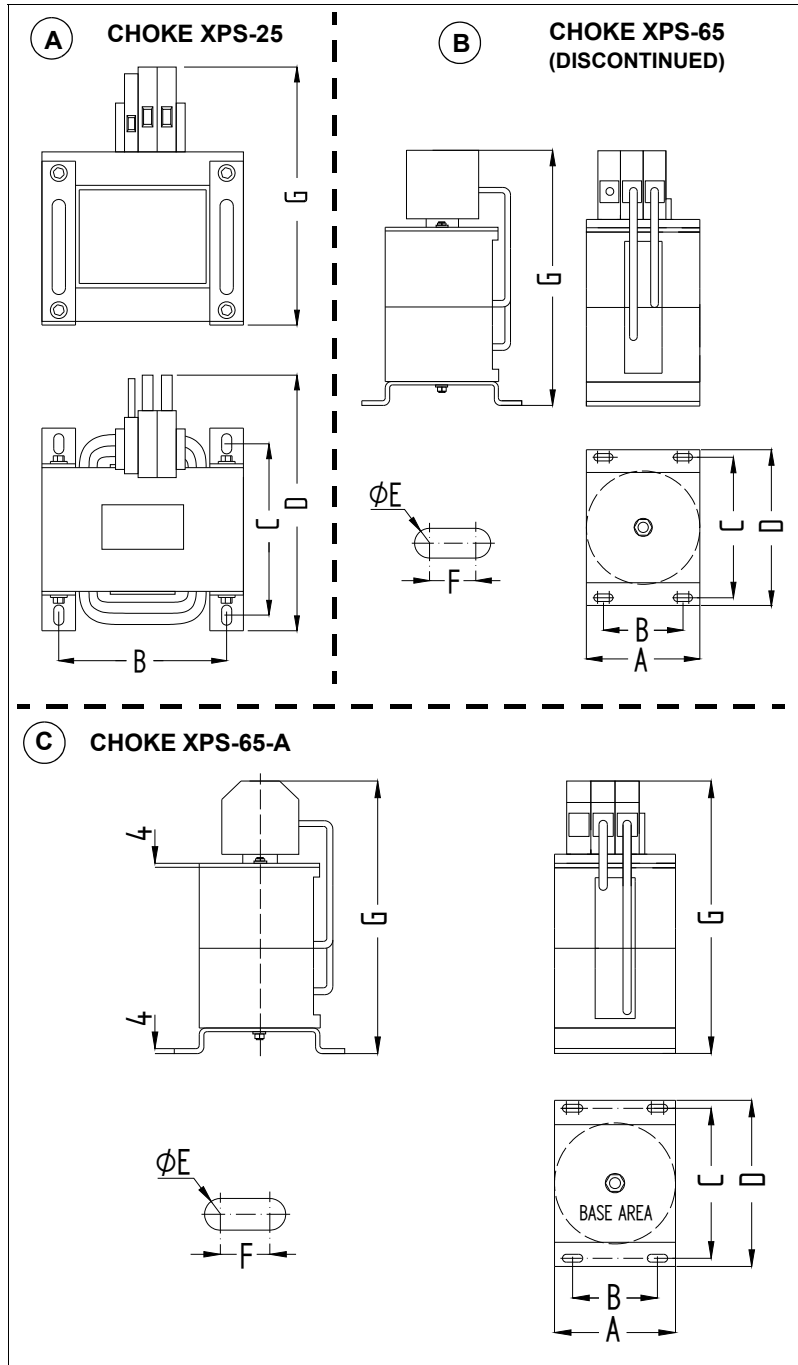

F. H11/6

A. PS-25 CHOKE. B. XPS-65 CHOKE. C. XPS-65-A CHOKE.

T. H11/2 Dimensions.

	CHOKE XPS-25		CHOKE XPS-65 (DISCONTINUED)		CHOKE XPS-65-A (NEW)	
Units	mm	inches	mm	inches	mm	inches
<b>A</b>	-	-	100	3.93	120	4.72
<b>B</b>	105	4.13	75	2.95	85	3.34
<b>C</b>	115	4.52	136	5.35	152	5.98
<b>D</b>	180	7.08	150	5.90	170	6.69
<b>E</b>	8	0.31	8	0.31	9	0.35
<b>F</b>	10	0.39	15	0.59	9	0.35
<b>G</b>	165	6.49	228	8.97	266	10.47



DDS  
HARDWARE

Ref.1310

## 11.7 RPS chokes

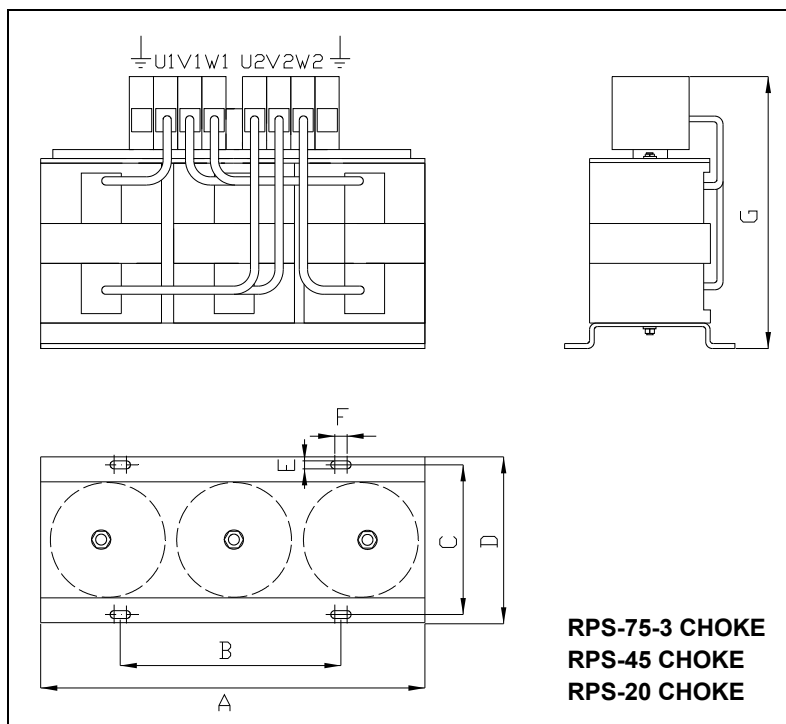

### F. H11/7

Chokes RPS-75-3, RPS-45 and RPS-20.

### T. H11/3 Dimensions.

	CHOKE RPS-20		CHOKE RPS-45		RPS-75-3 CHOKE	
	mm	inches	mm	inches	mm	inches
<b>A</b>	330	12.99	330	12.99	380	14.96
<b>B</b>	175	6.88	175	6.88	235	9.25
<b>C</b>	136	5.35	136	5.35	152	5.98
<b>D</b>	150	5.90	150	5.90	170	6.69
<b>E</b>	8	0.31	8	0.31	9	0.35
<b>F</b>	15	0.59	15	0.59	18	0.70
<b>G</b>	162	6.37	228	8.97	271	10.66

11.

DIMENSIONS

RPS chokes

## 11.8 External Ballast resistors with external thermostat

# 11.

### DIMENSIONS

External Ballast resistors with external thermostat

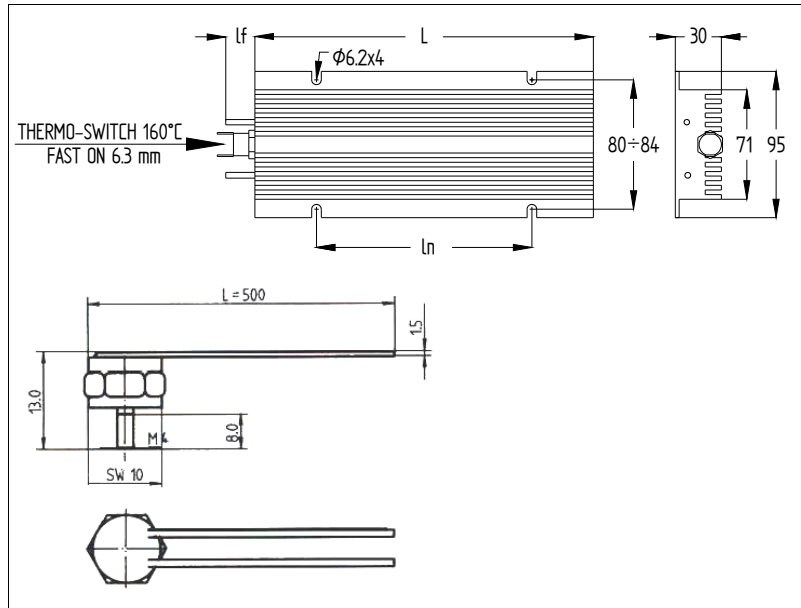

**F. H11/8**

External Ballast resistors with external thermostat.

**T. H11/4** Dimensions.

With external thermostat	ER+TH-43/350		ER+TH-24/750		ER+TH-24/1100	
	mm	inches	mm	inches	mm	inches
<b>L</b>	110	4.33	220	8.66	320	12.59
<b>ln</b>	60	2.36	140	5.51	240	9.44
<b>lf</b>	300	11.81	300	11.81	300	11.81

**T. H11/5** Dimensions.

With external thermostat	ER+TH-18/1100					
	mm	inches				
<b>L</b>	320	12.59				
<b>ln</b>	240	9.44				
<b>lf</b>	300	11.81				



DDS  
HARDWARE

Ref.1310

## 11.9 External Ballast resistors with internal thermostat

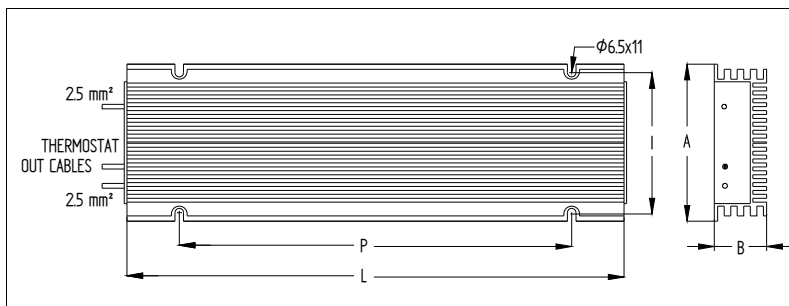

### F. H11/9

External Ballast resistor with internal thermostat.

### T. H11/6 Dimensions.

With internal thermostat	ER+TH-18/1800		ER+TH-18/2200	
	mm	inches	mm	inches
Units				
<b>A</b>	120	4.72	190	7.48
<b>B</b>	40	1.57	67	2.63
<b>L</b>	380	14.96	380	14.96
<b>I</b>	107÷112	4.21÷4.40	177÷182	6.96÷7.16
<b>P</b>	300	11.81	300	11.81

# 11.

**DIMENSIONS**

External Ballast resistors with internal thermostat

**FAGOR** 

**DDS  
HARDWARE**

**Ref.1310**

### 11.10 External Ballast resistors with external thermostat & cooling fan

# 11.

## DIMENSIONS

External Ballast resistors with external thermostat & cooling fan

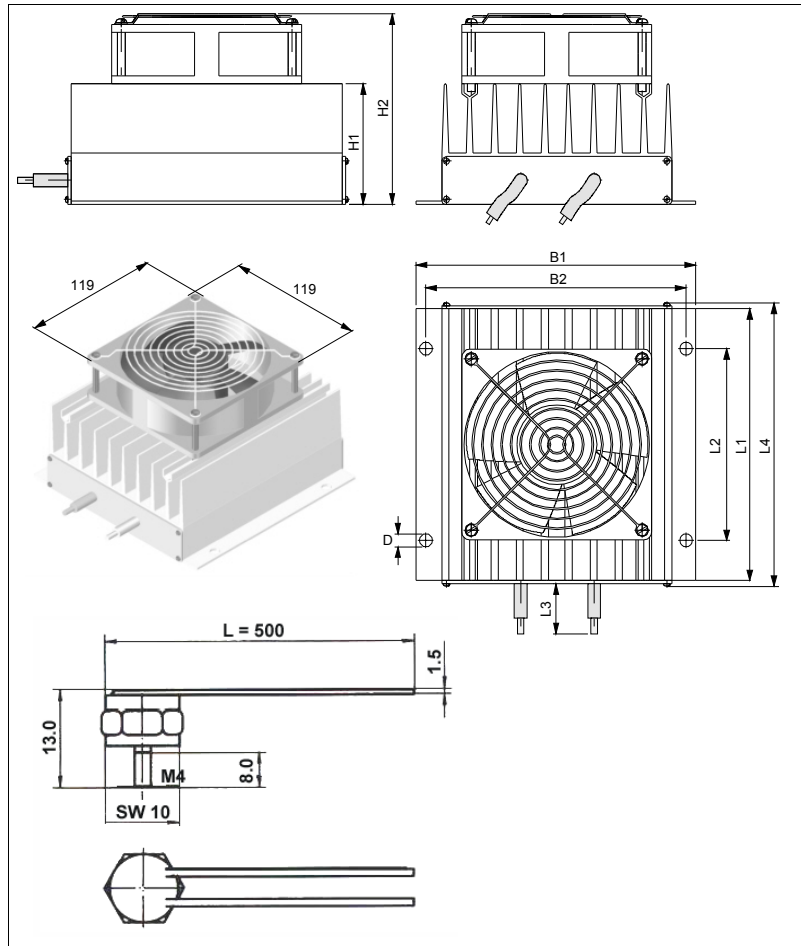

**F. H11/10**

External Ballast resistors with external thermostat and fan.

**T. H11/7** Dimensions.

With external thermostat & fan	ER+TH-18/1000+FAN		ER+TH-18/1500+FAN		ER+TH-18/2000+FAN	
	mm	inches	mm	inches	mm	inches
<b>B1</b>	175	6.88	175	6.88	175	6.88
<b>B2</b>	165	6.49	165	6.49	165	6.49
<b>H1</b>	75	2.95	75	2.95	75	2.95
<b>H2</b>	119	4.68	119	4.68	119	4.68
<b>L1</b>	170	6.69	330	12.99	530	20.86
<b>L2</b>	120	4.72	280	11.02	500	19.68
<b>L3</b>	250	9.84	250	9.84	250	9.84
<b>D</b>	6.5	2.55	6.5	2.55	6.5	2.55



DDS  
HARDWARE

Ref.1310

This chapter indicates the sales references of all FAGOR products.

It refers to:

Synchronous servo motors	FXM, FKM
Asynchronous servo motors	FM7, FM9
Modular drives	AXD, SPD
Compact drives	ACD, SCD
MC drives	MMC, CMC
Power supply module	PS-25B4, PS-65, XPS-25, XPS-65, RPS-80, RPS-75, RPS-45 and RPS-20
Accessory modules	"MAINS FILTER □A" mains filters, auxiliary power supply "APS-24", capacitor module "CM 1.60", external braking resistor modules "ER+TH-□/□" and "ER+TH-18/□+FAN".
Chokes	Chokes XPS-25, XPS-65-A Chokes RPS-75-3, RPS-45 and RPS-20
Cables	For signal and power
	SERCOS interface (fiber optics)
	CAN interface (cable)
	MPC 4x ... and MPC 4x...+2x1
Connectors	On FXM and FKM motors

where it describes the meaning of each field of the sales reference of the product.

At the end of the chapter, it shows an example of how to place an order for the products of the FAGOR catalog.



Sales reference of the synchronous servo motors, FKM.

<b>FKM</b> □ □ . □ □ □ . □ □ □ . □ □ □ - <b>K</b> □ □	
<b>FAGOR SYNCHRONOUS MOTOR</b>	
<b>SIZE</b>	2, 4, 6      8
<b>LENGTH</b>	1, 2, 4, 6      2, 3, 4, 5
<b>RATED SPEED</b>	20 2000 rev/min    45 4500 rev/min 30 3000 rev/min    50 5000 rev/min 40 4000 rev/min    60 6000 rev/min
<b>WINDING</b>	A 400 V AC F 220 V AC
<b>FEEDBACK TYPE</b>	I0 Incremental encoder (2500 ppt) A3 Absolute multi-turn SinCos encoder (1024 ppt) E3 SinCos encoder (1024 ppt)
<b>FLANGE &amp; SHAFT</b>	0 With keyway (half-key balancing) 1 Cylindrical (with no keyway) 2 Shaft with key and seal 3 Keyless shaft with seal
<b>BRAKE OPTION</b>	0 Whitout brake 1 With standard brake (24 V DC)
<b>CONNECTION</b>	0 Rotating angled connectors 1 Cable output without connectors 9 Special  2 Optimized for ACSD-16H
<b>SPECIAL CONFIGURATION</b>	K
<b>SPECIFICATION</b>	01 → ZZ Only when it has a special configuration (K)!
<b>FKM</b> □ □ . □ □ □ . □ □ □ . □ □ □	
<b>MOTOR SERIES</b>	
<b>SIZE</b>	9
<b>LENGTH</b>	4, 5, 6
<b>RATED SPEED</b>	20 2000 rev/min
<b>WINDING</b>	A 400 V AC
<b>FEEDBACK TYPE</b>	E3 Sinusoidal SinCos 1024 ppt A3 Absolute multi-turn SinCos 1024 ppt
<b>FLANGE &amp; SHAFT</b>	2 With keyway (standard) / IP 65 3 Cylindrical (with no keyway) / IP 65
<b>BRAKE OPTION</b>	0 Without brake 1 With brake
<b>FAN</b>	0 Whitout fan

**F. H12/2**

Sales reference of the synchronous servo motors, FKM.

**12.**

SALES REFERENCES  
References of synchronous servo motors



DDS  
HARDWARE

Ref.1310

## 12.2 References of asynchronous motors

Sales reference of the asynchronous motors, FM7.

# 12.

SALES REFERENCES  
References of asynchronous motors

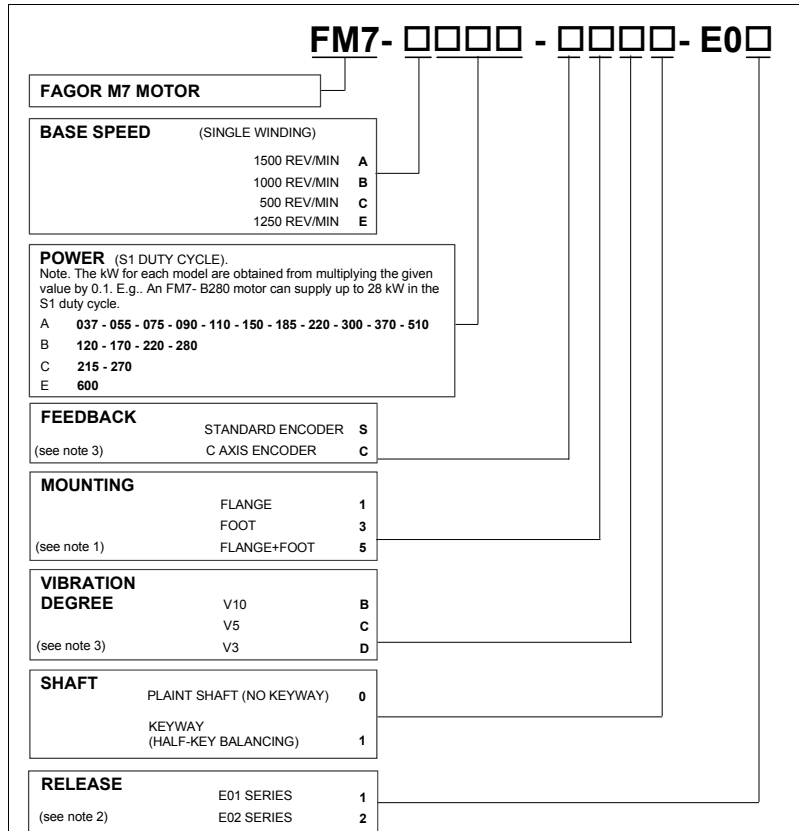

**NOTE 1.** The "flange + foot" mount type comes in all models except A037, A055, A075 and A090. **NOTE 2.** Models A300, A370, B220, B280 and E600 are not available for the E02 series. **NOTE 3.** E600 models can only have the C axis option for feedback and V10 vibration degree.

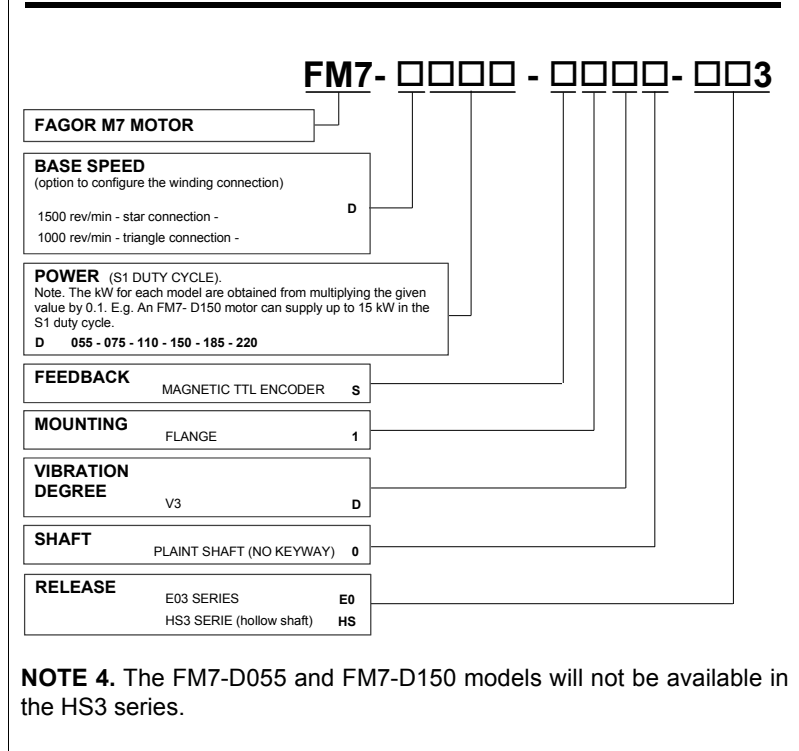

**NOTE 4.** The FM7-D055 and FM7-D150 models will not be available in the HS3 series.

### F. H12/3

Sales reference of the asynchronous motors, FM7.



DDS  
HARDWARE

Ref.1310

## 12.3 References of modular drives

Sales reference of the modular drives for synchronous axis servo motors, AXD.

**MODULAR AXIS DRIVE, AXD** Example: **AXD 1 . 08 - C0 - 2 - B**

<b>AXIS DRIVE</b>																									
SIZE	1 77 mm (08/15/25/35)																								
Width (mm)	2 117 mm (50/75)																								
(Models)	3 234 mm (100/150)																								
CURRENT (A)	<table border="1"> <tr> <td>08</td> <td>4.0</td> <td>8</td> </tr> <tr> <td>15</td> <td>7.5</td> <td>15</td> </tr> <tr> <td>25</td> <td>12.5</td> <td>25</td> </tr> <tr> <td>35</td> <td>17.5</td> <td>35</td> </tr> <tr> <td>50</td> <td>25.0</td> <td>50</td> </tr> <tr> <td>75</td> <td>37.5</td> <td>75</td> </tr> <tr> <td>100</td> <td>50.0</td> <td>100</td> </tr> <tr> <td>150</td> <td>75.0</td> <td>150</td> </tr> </table>	08	4.0	8	15	7.5	15	25	12.5	25	35	17.5	35	50	25.0	50	75	37.5	75	100	50.0	100	150	75.0	150
08	4.0	8																							
15	7.5	15																							
25	12.5	25																							
35	17.5	35																							
50	25.0	50																							
75	37.5	75																							
100	50.0	100																							
150	75.0	150																							
IS1 / I <sub>max</sub>																									
for IGBT switching																									
frequencies of 4 and 8 kHz.																									
INTERFACE	<b>A1</b> Analog I/O <b>S0</b> SERCOS <b>SI</b> SERCOS and Analog I/O <b>C0</b> CAN <b>SD</b> SERCOS, Analog and Digital 8/16O																								
ADDITIONAL FEEDBACK FEATURES	<b>0</b> None <b>1</b> Encoder simulator <b>2</b> Direct feedback																								
MOTOR FEEDBACK BOARD	<b>None</b> CAPMOTOR-1 <b>B</b> CAPMOTOR-2																								

**Note.** Models with CAN interface (C0) cannot have an encoder simulator board, in other words, there are no models with reference AXD X.XX-C0-1-X.

**Examples.**

**AXD 1.08-C0-2** Modular axis drive, size 1, I<sub>max</sub>. 8 A, with CAN board, with Direct feedback board and with CAPMOTOR-1 motor feedback board.

**AXD 1.08-C0-2-B** Modular axis drive, size 1, I<sub>max</sub>. 8 A, with CAN board, with Direct feedback board and with CAPMOTOR-2 motor feedback board.

### F. H12/4

Sales reference of the AXD modular drive.

Sales reference of the modular drives for synchronous or asynchronous spindle motors, SPD.

**MODULAR SPINDLE DRIVE, SPD** Example: **SPD 2 . 50 - C0 - 2 - B**

<b>SPINDLE DRIVE</b>																																																																												
SIZE	1 77 mm (08/15/25/35)																																																																											
Width(mm)	2 117 mm (50/75/85)																																																																											
(Models)	3 234 mm (100/150/200/250)																																																																											
CURRENT (A)	<table border="1"> <tr> <td></td> <td colspan="2">for fc = 4 kHz</td> <td colspan="2">for fc = 8 kHz</td> </tr> <tr> <td>IS1 / I<sub>max</sub>.</td> <td>15</td> <td>10.5</td> <td>13.7</td> <td>15</td> <td>10.5</td> <td>11.6</td> </tr> <tr> <td>fc: IGBT's switching frequencies.</td> <td>25</td> <td>16.0</td> <td>20.8</td> <td>25</td> <td>13.0</td> <td>16.9</td> </tr> <tr> <td></td> <td>35</td> <td>23.1</td> <td>30.0</td> <td>35</td> <td>18.0</td> <td>23.4</td> </tr> <tr> <td></td> <td>50</td> <td>31.0</td> <td>40.3</td> <td>50</td> <td>27.0</td> <td>35.1</td> </tr> <tr> <td></td> <td>75</td> <td>42.0</td> <td>54.6</td> <td>75</td> <td>32.0</td> <td>41.6</td> </tr> <tr> <td></td> <td>85</td> <td>50.0</td> <td>65.0</td> <td>85</td> <td>37.0</td> <td>48.1</td> </tr> <tr> <td></td> <td>100</td> <td>70.0</td> <td>91.0</td> <td>100</td> <td>56.0</td> <td>72.8</td> </tr> <tr> <td></td> <td>150</td> <td>90.0</td> <td>117.0</td> <td>150</td> <td>70.0</td> <td>91.0</td> </tr> <tr> <td></td> <td>200</td> <td>121.0</td> <td>157.3</td> <td>200</td> <td>97.0</td> <td>126.1</td> </tr> <tr> <td></td> <td>250</td> <td>135.0</td> <td>175.5</td> <td>250</td> <td>108.0</td> <td>140.4</td> </tr> </table>		for fc = 4 kHz		for fc = 8 kHz		IS1 / I <sub>max</sub> .	15	10.5	13.7	15	10.5	11.6	fc: IGBT's switching frequencies.	25	16.0	20.8	25	13.0	16.9		35	23.1	30.0	35	18.0	23.4		50	31.0	40.3	50	27.0	35.1		75	42.0	54.6	75	32.0	41.6		85	50.0	65.0	85	37.0	48.1		100	70.0	91.0	100	56.0	72.8		150	90.0	117.0	150	70.0	91.0		200	121.0	157.3	200	97.0	126.1		250	135.0	175.5	250	108.0	140.4
	for fc = 4 kHz		for fc = 8 kHz																																																																									
IS1 / I <sub>max</sub> .	15	10.5	13.7	15	10.5	11.6																																																																						
fc: IGBT's switching frequencies.	25	16.0	20.8	25	13.0	16.9																																																																						
	35	23.1	30.0	35	18.0	23.4																																																																						
	50	31.0	40.3	50	27.0	35.1																																																																						
	75	42.0	54.6	75	32.0	41.6																																																																						
	85	50.0	65.0	85	37.0	48.1																																																																						
	100	70.0	91.0	100	56.0	72.8																																																																						
	150	90.0	117.0	150	70.0	91.0																																																																						
	200	121.0	157.3	200	97.0	126.1																																																																						
	250	135.0	175.5	250	108.0	140.4																																																																						
INTERFACE	<b>A1</b> Analog I/O <b>S0</b> SERCOS <b>SI</b> SERCOS and Analog I/O <b>C0</b> CAN																																																																											
ADDITIONAL FEEDBACK FEATURES	<b>0</b> None <b>1</b> Encoder simulator <b>2</b> Direct feedback																																																																											
MOTOR FEEDBACK BOARD	<b>None</b> CAPMOTOR-1 <b>B</b> CAPMOTOR-2																																																																											

**Note.** Models with CAN interface (C0) cannot have an encoder simulator board, in other words, there are no models with references like SPD X.XX-C0-1-X

**Examples.**

**SPD 1.08-C0-2** Modular spindle drive, size 1, I<sub>max</sub>. 8 A, with CAN board, with Direct feedback board and with CAPMOTOR-1 motor feedback board.

**SPD 1.08-C0-2-B** Modular spindle drive, size 1, I<sub>max</sub>. 8 A, with CAN board, with Direct feedback board and with CAPMOTOR-2 motor feedback board.

### F. H12/5

Sales reference of the SPD modular drive.

**12.**  
**SALES REFERENCES**  
 References of modular drives



**DDS  
HARDWARE**

**Ref.1310**

## 12.4 References of compact drives

Sales reference of the compact drives for synchronous axis servo motors, ACD.

# 12.

SALES REFERENCES  
References of compact drives

**AXIS COMPACT DRIVE, ACD** Example: ACD 2 . 50 - C0 - 2 - B

<b>AXIS COMPACT DRIVE</b>																																					
<b>SIZE</b> Width (mm) (Models)	<b>1</b> 77 mm (08/15/25) <b>2</b> 177 mm (35/50)																																				
<b>CURRENT (A)</b> Irated / Ipeak fc: IGBT's switching frequencies.	<table border="1"> <tr> <th colspan="3">for fc = 4 kHz</th> <th colspan="3">for fc = 8 kHz</th> </tr> <tr> <td><b>08</b></td><td>4.0</td><td>8.0</td> <td><b>08</b></td><td>4.0</td><td>8.0</td> </tr> <tr> <td><b>15</b></td><td>7.5</td><td>15.0</td> <td><b>15</b></td><td>7.5</td><td>15.0</td> </tr> <tr> <td><b>25</b></td><td>12.5</td><td>25.0</td> <td><b>25</b></td><td>9.5</td><td>19.0</td> </tr> <tr> <td><b>35</b></td><td>17.5</td><td>35.0</td> <td><b>35</b></td><td>17.5</td><td>35.0</td> </tr> <tr> <td><b>50</b></td><td>25.0</td><td>50.0</td> <td><b>50</b></td><td>20.0</td><td>40.0</td> </tr> </table>	for fc = 4 kHz			for fc = 8 kHz			<b>08</b>	4.0	8.0	<b>08</b>	4.0	8.0	<b>15</b>	7.5	15.0	<b>15</b>	7.5	15.0	<b>25</b>	12.5	25.0	<b>25</b>	9.5	19.0	<b>35</b>	17.5	35.0	<b>35</b>	17.5	35.0	<b>50</b>	25.0	50.0	<b>50</b>	20.0	40.0
for fc = 4 kHz			for fc = 8 kHz																																		
<b>08</b>	4.0	8.0	<b>08</b>	4.0	8.0																																
<b>15</b>	7.5	15.0	<b>15</b>	7.5	15.0																																
<b>25</b>	12.5	25.0	<b>25</b>	9.5	19.0																																
<b>35</b>	17.5	35.0	<b>35</b>	17.5	35.0																																
<b>50</b>	25.0	50.0	<b>50</b>	20.0	40.0																																
<b>INTERFACE</b>	<b>A1</b> Analog I/O <b>S0</b> SERCOS <b>SI</b> SERCOS and Analog I/O <b>C0</b> CAN																																				
<b>ADDITIONAL FEEDBACK FEATURES</b>	<b>0</b> None <b>1</b> Encoder simulator <b>2</b> Direct feedback																																				
<b>MOTOR FEEDBACK BOARD</b>	<b>None</b> CAPMOTOR-1 <b>B</b> CAPMOTOR-2																																				

**Note.** Models with CAN interface (C0) cannot have an encoder simulator board, in other words, there are no models with references like ACD X.XX- C0 -1-X

**Examples:**

**ACD 1.25-C0-2-A** Compact axis drive, size 1, with a peak current of 25 A at 4 kHz, with CAN board, with Direct feedback board and with CAPMOTOR-1 motor feedback board.

**ACD 1.25-C0-2-B** Compact axis drive, size 1, with a peak current of 25 A at 4 kHz, with CAN board, with Direct feedback board and with CAPMOTOR-2 motor feedback board.

**ACD 1.08-C0-2** Compact axis drive, size 1, with a peak current of 8 A at 4 kHz, with CAN board, with Direct feedback board and with CAPMOTOR-1 motor feedback board.

### F. H12/6

Sales reference of the ACD compact drive.

Sales reference of the compact drives for synchronous or asynchronous spindle motors, SCD.

**COMPACT SPINDLE DRIVE, SCD** Example: SCD 2.50-C0-2-B-NR

<b>SPINDLE COMPACT DRIVE</b>																									
<b>SIZE</b> Width mm (Models)	<b>1</b> 77 mm (15/25) <b>2</b> 177 mm (35/50/75)																								
<b>CURRENT (A)</b> Imax. in any duty cycle fc: IGBT's switching frequencies	<table border="1"> <tr> <th colspan="2">for fc = 4 kHz</th> <th colspan="2">for fc = 8 kHz</th> </tr> <tr> <td><b>15</b></td><td>10.6</td> <td><b>15</b></td><td>10.6</td> </tr> <tr> <td><b>25</b></td><td>17.5</td> <td><b>25</b></td><td>12.5</td> </tr> <tr> <td><b>35</b></td><td>28.0</td> <td><b>35</b></td><td>19.5</td> </tr> <tr> <td><b>50</b></td><td>38.0</td> <td><b>50</b></td><td>27.0</td> </tr> <tr> <td><b>75</b></td><td>52.0</td> <td><b>75</b></td><td>39.0</td> </tr> </table>	for fc = 4 kHz		for fc = 8 kHz		<b>15</b>	10.6	<b>15</b>	10.6	<b>25</b>	17.5	<b>25</b>	12.5	<b>35</b>	28.0	<b>35</b>	19.5	<b>50</b>	38.0	<b>50</b>	27.0	<b>75</b>	52.0	<b>75</b>	39.0
for fc = 4 kHz		for fc = 8 kHz																							
<b>15</b>	10.6	<b>15</b>	10.6																						
<b>25</b>	17.5	<b>25</b>	12.5																						
<b>35</b>	28.0	<b>35</b>	19.5																						
<b>50</b>	38.0	<b>50</b>	27.0																						
<b>75</b>	52.0	<b>75</b>	39.0																						
<b>INTERFACE</b>	<b>A1</b> Analog I/O <b>S0</b> SERCOS <b>SI</b> SERCOS and analog I/O <b>C0</b> CAN																								
<b>ADDITIONAL FEEDBACK FEATURES</b>	<b>0</b> None <b>1</b> Encoder simulator <b>2</b> Direct feedback																								
<b>MOTOR FEEDBACK BOARD</b>	<b>None</b> CAPMOTOR-1 <b>B</b> CAPMOTOR-2																								
<b>BRAKING RESISTOR</b>	<b>None</b> Includes external Ballast resistor <b>NR</b> Does not include external Ballast resistor																								

**Note.** Models with CAN interface (C0) cannot have an encoder simulator board, in other words, there are no models with references like SCD X.XX- C0 -1-X.

**Examples.**

**SCD 2.50-C0-2** Compact spindle drive, size 2, with Imax of 50 A at 4 kHz, with CAN board, with Direct feedback board and with CAPMOTOR-1 motor feedback board.

**SCD 2.50-C0-2-B** Compact spindle drive, size 2, with Imax of 50 A at 4 kHz, with CAN board, with Direct feedback board and with CAPMOTOR-2 motor feedback board.

### F. H12/7

Sales reference of the SCD compact drive.



DDS  
HARDWARE

Ref.1310

## 12.5 References of positioning drives

Sales reference of the modular positioning drive for synchronous axis motors, MMC.

**MODULAR POSITIONING DRIVE, MMC** Example: MMC 1 - 25 - C0 - D2 - D1 - 1 - 0 - B

<b>MODULAR MOTION CONTROL (AXIS POSITIONING DRIVE)</b>	
SIZE	1 77 mm (08/15/25/35)
Width (mm)	2 117 mm (50/75)
(Models)	3 234 mm (100/150/200)
CURRENT (A)	08 4.0 8
IS1 / I <sub>max</sub>	15 7.5 15
for IGBT switching	25 12.5 25
frequencies	35 17.5 35
of 4 and 8 kHz	50 25.0 50
	75 37.5 75
	100 50.0 100
	150 75.0 150
	200 90.0 180
INTERFACE	00 None
	S0 SERCOS
	RS RS422-485
	C0 CAN
SL2	00 None
	D1 16I/8O
	D2 8I/16O
SL1	A1 Analog I/O
	D1 16I/8O
	D2 8I/16O
ADDITIONAL FEEDBACK FEATURES	0 None
	1 Encoder simulator
	2 Direct feedback
SOFTWARE APPLICATIONS	0 None
MOTOR FEEDBACK BOARD	None CAPMOTOR-1
	B CAPMOTOR-2

**Note.** SLOT 1 must always carry a card. There are no model with sales references like MMC X.XX-XX-00.XX-X-X. If the user wants to have 24I/24O, the selection will be done using reference MMC X.XX-XX-D2.D1-X-X, not using ref. MMC X.XX-XX-D1.D2-X-X which is not available.

**Examples.**

**MMC 1.08-C0-D2.D1-2-0** Modular positioning drive, size 1, 8 A, with CAN board, with 8I/16O and 16I/8O boards, with direct feedback board, without soft applications and with CAPMOTOR-1.

**MMC 1.08-C0-D2.D1-2-0-B** Modular positioning drive, size 1, 8 A, with CAN board, with 8I/16O and 16I/8O boards, with direct feedback board, without soft applications and with CAPMOTOR-2.

# 12.

SALES REFERENCES  
References of positioning drives

### F. H12/8

Sales reference of the modular positioning drive for MC, MMC.

Sales reference of the compact positioning drive for synchronous axis motors, CMC.

**COMPACT POSITIONING DRIVE, CMC** Example: CMC 2.50 - C0 - D2.D1 - 2 - 0 - B

<b>COMPACT MOTION CONTROL</b>		
SIZE	1 77 mm (08/15/25)	
Width (mm)	2 177 mm (35/50)	
(Models)		
CURRENT (A)	with fc = 4 kHz	with fc = 8 kHz
I <sub>rated</sub> / I <sub>peak</sub>	08 4.0 8.0	08 4.0 8.0
for IGBT switching	15 7.5 15.0	15 7.5 15.0
frequencies	25 12.5 25.0	25 9.5 19.0
of 4 and 8 kHz	35 17.5 35.0	35 17.5 35.0
	50 25.0 50.0	50 20.0 40.0
INTERFACE	00 None	
	S0 SERCOS	
	RS RS422-485	
	C0 CAN	
SL2	00 None	
	D1 16I/8O	
	D2 8I/16O	
SL1	A1 Analog I/O	
	D1 16I/8O	
	D2 8I/16O	
ADDITIONAL FEEDBACK FEATURES	0 None	
	1 Encoder simulator	
	2 Direct feedback	
SOFTWARE APPLICATIONS	0 None	
MOTOR FEEDBACK BOARD	None CAPMOTOR-1	
	B CAPMOTOR-2	

**Note.** SLOT 1 must always have a card. There are no models like CMC X.XX-XX-00.XX-X-X. If the user wants to have 24I/24O, the selection must be done according to the reference CMC X.XX-XX-D2.D1-X-X and not according to the reference CMC X.XX-XX-D1.D2-X-X that is not available.

**Examples.**

**CMC 2.50-C0-D2.D1-2-0** Compact positioning drive, size 2, with a peak current of 50 A (4 kHz), with CAN board, with 8I/16O and 16I/8O boards, with direct feedback, without soft applications and with CAPMOTOR-1.

**CMC 2.50-C0-D2.D1-2-0-B** Compact positioning drive, size 2, with a peak current of 50 A (4 kHz), with CAN board, with 8I/16O and 16I/8O boards, with direct feedback, without soft applications and with CAPMOTOR-2.



DDS  
HARDWARE

Ref.1310

### F. H12/9

Sales reference of the compact positioning drive for MC, CMC.

## 12.6 Power supply references

Sales reference of the power supplies, PS-65A.

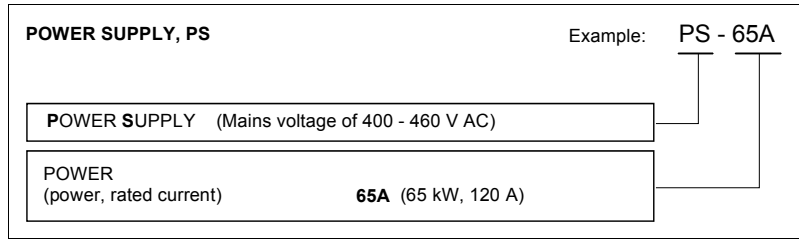

### F. H12/10

Sales reference of the non-regenerative power supply, PS-65A.

Sales reference of the power supplies, PS-25B4.

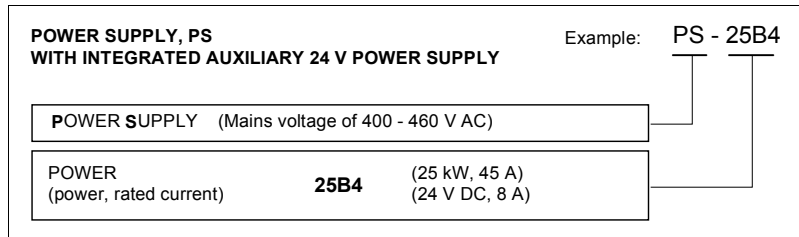

### F. H12/11

Sales reference of the non-regenerative power supply, PS-25B4.

Sales reference of the power supplies, XPS.

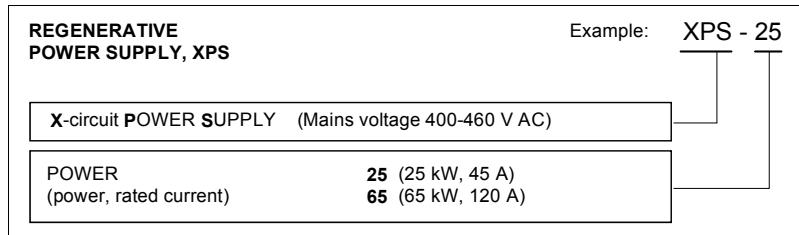

### F. H12/12

Sales reference of the regenerative power supplies, XPS.

Sales reference of the power supplies, RPS.

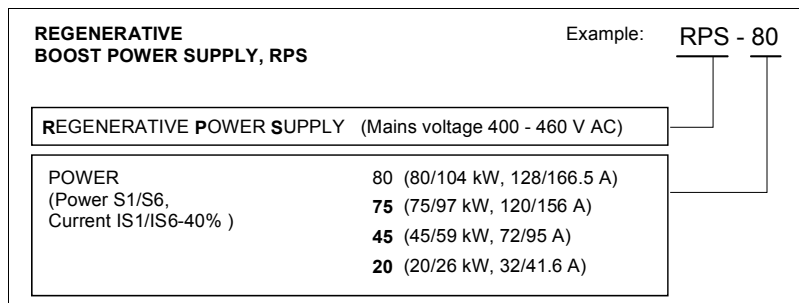

### F. H12/13

Sales reference of the regenerative regulated power supplies, RPS.

12.

SALES REFERENCES  
Power supply references



DDS  
HARDWARE

Ref.1310

## 12.7 References of other elements

Sales reference of accessory modules.

ACCESORY MODULES		Example: <u>MAINS FILTER 42A</u>	
FAGOR MAINS FILTER			
<b>MAINS FILTER</b>			
MAX. CURRENT	<b>MAINS FILTER 42A</b> 42 A <b>MAINS FILTER 130A</b> 130 A <b>MAINS FILTER 180A</b> 180 A		
AUXILIARY POWER SUPPLY (24 V DC)		APS-24	
CAPACITOR MODULE (4 mF)		CM 1.60	
EXTERNAL RESISTOR WITH EXTERNAL THERMOSTAT (Resistance, RMS power)		(43 Ω, 300 W) <b>ER+TH-43/350</b> (24 Ω, 650 W) <b>ER+TH-24/750</b> (24 Ω, 950 W) <b>ER+TH-24/1100</b> (18 Ω, 950 W) <b>ER+TH-18/1100</b>	
EXTERNAL RESISTOR WITH INTERNAL THERMOSTAT (Resistance, RMS power)		(18 Ω, 1300 W) <b>ER+TH-18/1800</b> (18 Ω, 2000 W) <b>ER+TH-18/2200</b>	
EXTERNAL RESISTOR WITH EXTERNAL THERMOSTAT AND COOLING FAN (Resistance, RMS power)		(18 Ω, 2000 W) <b>ER+TH-18/1000+FAN</b> (18 Ω, 3000 W) <b>ER+TH-18/1500+FAN</b> (18 Ω, 4000 W) <b>ER+TH-18/2000+FAN</b>	

### F. H12/14

Sales reference of accessory modules.

Sales reference of the chokes for regenerative power supplies.

INDUCTANCES		Example: <u>CHOKE XPS-25</u>	
CHOKE    INDUCTIVE FILTER			
For regenerative power supplies	Chokes		
XPS-25	Choke XPS-25		
XPS-65	Choke XPS-65-A		
RPS-80	Choke RPS-75-3		
RPS-75	Choke RPS-75-3		
RPS-45	Choke RPS-45		
RPS-20	Choke RPS-20		

### F. H12/15

Sales reference of the chokes for regenerative power supplies.

# 12.

SALES REFERENCES  
References of other elements



DDS  
HARDWARE

Ref.1310

## 12.8 Cable references

Sales reference of power cables.

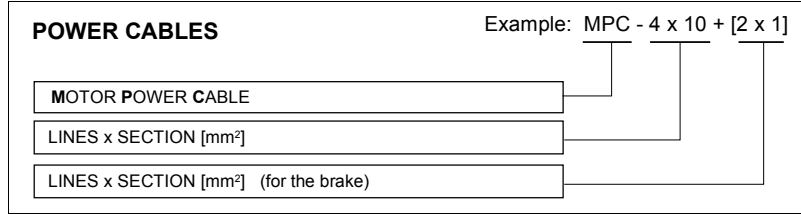

### F. H12/16

Sales reference of power cables.

Sales reference of signal cables.

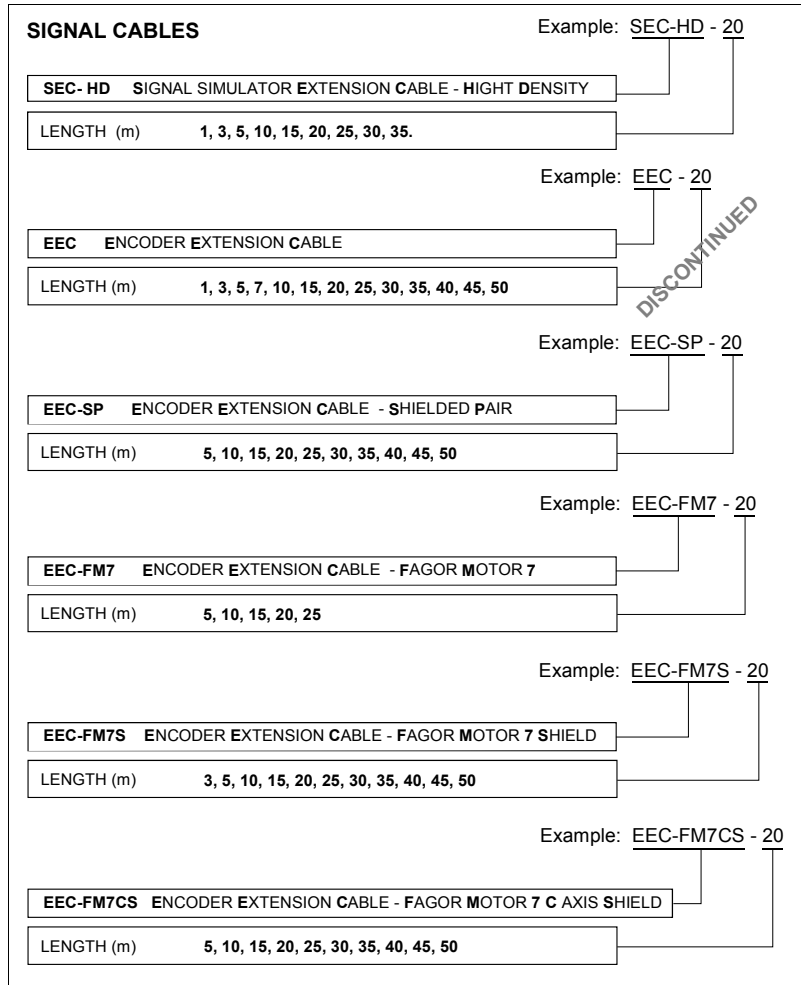

### F. H12/17

Sales reference of signal cables.

**12.**  
**SALES REFERENCES**  
 Cable references



DDS  
HARDWARE

Ref.1310

Sales reference of the SERCOS interface cable

<b>FIBER OPTIC LINES</b> (Polymer core)		Example: <u>SFO - 2</u>
<b>SFO</b>	SERCOS FIBER OPTIC	
LENGTH (m)	1, 2, 3, 5, 7, 10, 12	
<b>FIBER OPTIC LINES</b> (Polymer core)		Example: <u>SFO - FLEX - 15</u>
<b>SFO - FLEX</b>	SERCOS FIBER OPTIC - FLEX	
LENGTH (m)	10, 15, 20, 25, 30, 35, 40	
<b>FIBER OPTIC LINES</b> (Glass core)		Example: <u>SFO - V - FLEX - 60</u>
<b>SFO - V - FLEX</b>	SERCOS FIBER OPTIC - V - FLEX	
LENGTH (m)	40, 50, 60, 75, 100	

**F. H12/18**

Sales reference of the SERCOS interface cable.

Sales reference of the CAN interface cable

<b>CAN CABLE</b>		Example: <u>CAN CABLE 5M</u>
<b>CAN CABLE</b>		
LENGTH (m)	5M, 10M, 15M, 20M, 25M	

**F. H12/19**

Sales reference of the CAN interface cable.

Sales reference of the connectors for synchronous servo motors.

<b>CONNECTORS FOR THE FXM MOTORS</b>		Example: <u>MC 23</u>
POWER CONNECTOR FOR FXM	<b>AMC</b> Angled <b>MC</b> Vertical	
MAX. CURRENT	<b>23</b> (23 A) <b>46</b> (46 A) <b>80</b> (80 A)	
ENCODER FEEDBACK CONNECTOR (12 pines)		
<b>CONNECTORS FOR THE FKM MOTORS</b>		Example: <u>MC 61/6</u>
POWER CONNECTOR FOR FKM	<b>MC</b>	
MAX. CURRENT	<b>20/6</b> (20 A) <b>61/6</b> (61 A)	
ENCODER FEEDBACK CONNECTOR (12 pines)		

**F. H12/20**

Sales reference of the connectors for synchronous servo motors.

**12.**

**SALES REFERENCES**  
Cable references



**DDS**  
**HARDWARE**

**Ref.1310**

## 12.9 Order example

# 12.

SALES REFERENCES  
Order example

FAGOR AUTOMATION S. COOP. LTDA			UNIT	NET
QTY	REFERENCE	DESCRIPTION	PRICE	PRICE
			US \$	US \$
1	FXM 33.30A.R0.000	Axis motor 5,77 Nm, 3.000 with resolver		
1	FXM 33.30A.R0.000	Axis motor 5,77 Nm, 3.000 with resolver		
2	MC 23	Motor power connectors (socket)		
2	AXD 1.15-A1-1	15 A axis drives with encoder simulator		
1	SPM 112LE.E0.00000.1	7,5 kW S1 spindle (1.500 a 7.500 rev/min)		
1	SPD 2.50-A1-1	50 A spindle drive with encoder simulator		
1	PS-25A	25 kW Power Supply		
2	REC - 5	5 mts Resolver extension Cable		
1	EEC - 5	5 mts Encoder extension Cable		
3	SEC - 1	1 mt Signal Encoder Cable		
<b>TOTAL DRIVE SYSTEM</b>				

### F. H12/21

Order example.



DDS  
HARDWARE

Ref.1310

## 12.10 Module identification

Each electronic module is identified by its characteristics plate. It indicates the model and its main technical characteristics.

**WARNING.** The user must make sure that the references indicated on the packing list of the order match those supplied by each module on its characteristics plate before making any connection to avoid any possible shipping errors.

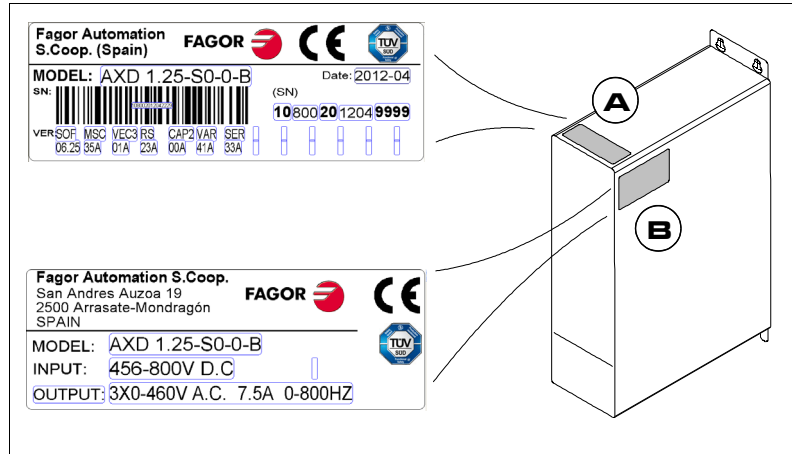

### F. H12/22

Module identification plates. **A.** Version label, **B.** Characteristics plate.

The versions plate shows the hardware and software versions of the equipment. For example, the IGBT board mounted in this module has version 01A (IGB); the software version is 0306 (SOF).

These two plates fully identify the module and must be referred to when repairing or replacing these units. They make it easier to solve compatibility conflicts between different versions.

The drive module is also labeled on its package:

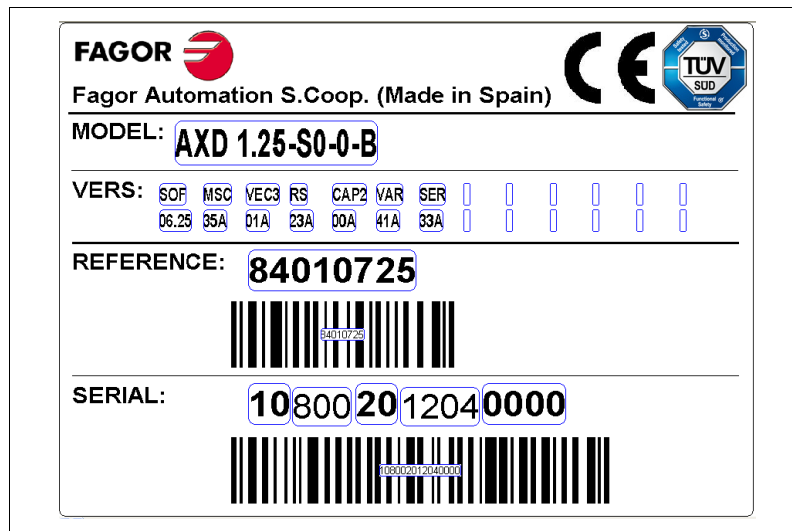

### F. H12/23

Packaging label of the drive module.

12.

SALES REFERENCES

Module identification



**DDS  
HARDWARE**

**Ref.1310**



## 13.1 Mains voltage

Originally, the drives and power supplies were designed for a mains voltage of 380 V AC (50/60 Hz). They all have been now redesigned to work with mains voltage ranging between 400-460 V AC (50/60 Hz).

Their identification comes on the label that each of these module has.

	Elements for 380 V AC	Elements for 400- 460 V AC																																
Power supplies	<table border="1"> <tr> <td colspan="2">Fagor Automation, S. Coop. (Spain)</td> <td>FAGOR</td> <td>CE</td> </tr> <tr> <td>MODEL</td> <td colspan="3">PS-25</td> </tr> <tr> <td>INPUT</td> <td colspan="3">3x380 Vac 50/60Hz</td> </tr> <tr> <td>OUTPUT</td> <td colspan="3">600 Vdc 45A</td> </tr> </table>	Fagor Automation, S. Coop. (Spain)		FAGOR	CE	MODEL	PS-25			INPUT	3x380 Vac 50/60Hz			OUTPUT	600 Vdc 45A			<table border="1"> <tr> <td colspan="2">Fagor Automation, S. Coop. (Spain)</td> <td>FAGOR</td> <td>CE</td> </tr> <tr> <td>MODEL</td> <td colspan="3">PS-25A</td> </tr> <tr> <td>INPUT</td> <td colspan="3">3x400-460Vac 50/60Hz</td> </tr> <tr> <td>OUTPUT</td> <td colspan="3">537-650 Vdc 45A</td> </tr> </table>	Fagor Automation, S. Coop. (Spain)		FAGOR	CE	MODEL	PS-25A			INPUT	3x400-460Vac 50/60Hz			OUTPUT	537-650 Vdc 45A		
Fagor Automation, S. Coop. (Spain)		FAGOR	CE																															
MODEL	PS-25																																	
INPUT	3x380 Vac 50/60Hz																																	
OUTPUT	600 Vdc 45A																																	
Fagor Automation, S. Coop. (Spain)		FAGOR	CE																															
MODEL	PS-25A																																	
INPUT	3x400-460Vac 50/60Hz																																	
OUTPUT	537-650 Vdc 45A																																	
Drives	<table border="1"> <tr> <td colspan="2">Fagor Automation, S. Coop. (Spain)</td> <td>FAGOR</td> <td>CE</td> </tr> <tr> <td>MODEL</td> <td colspan="3">AXD 1.15-A1-1</td> </tr> <tr> <td>INPUT</td> <td colspan="3">600-800 Vdc</td> </tr> <tr> <td>OUTPUT</td> <td colspan="3">3x380 Vac 7A 0-800Hz</td> </tr> </table>	Fagor Automation, S. Coop. (Spain)		FAGOR	CE	MODEL	AXD 1.15-A1-1			INPUT	600-800 Vdc			OUTPUT	3x380 Vac 7A 0-800Hz			<table border="1"> <tr> <td colspan="2">Fagor Automation, S. Coop. (Spain)</td> <td>FAGOR</td> <td>CE</td> </tr> <tr> <td>MODEL</td> <td colspan="3">AXD 1.15-A1-1</td> </tr> <tr> <td>INPUT</td> <td colspan="3">456-800 Vdc</td> </tr> <tr> <td>OUTPUT</td> <td colspan="3">3x0-460 Vac 7A 0-800Hz</td> </tr> </table>	Fagor Automation, S. Coop. (Spain)		FAGOR	CE	MODEL	AXD 1.15-A1-1			INPUT	456-800 Vdc			OUTPUT	3x0-460 Vac 7A 0-800Hz		
Fagor Automation, S. Coop. (Spain)		FAGOR	CE																															
MODEL	AXD 1.15-A1-1																																	
INPUT	600-800 Vdc																																	
OUTPUT	3x380 Vac 7A 0-800Hz																																	
Fagor Automation, S. Coop. (Spain)		FAGOR	CE																															
MODEL	AXD 1.15-A1-1																																	
INPUT	456-800 Vdc																																	
OUTPUT	3x0-460 Vac 7A 0-800Hz																																	

### F. H13/1

Module identification labels. Operating mains voltage.

## 13.2 Compatibility

The elements ready for mains voltage between 400-460 V AC:

- ❑ Drive (version MSC 12A and later).
- ❑ Auxiliary power supply APS-24 ( version PF 05A and later ).
- ❑ Capacitor module CM 60 (version 01A and later) or CM 1.60 (version [CAP 00A] [VAR 02A] and later) replacing the previous one.
- ❑ Mains filters EMK or MAINS FILTER ❑❑A **compatible** with all power supplies PS, XPS and RPS.

The elements ready for mains voltage between 380 V AC:

- ❑ Drive (version MSC 11A and older).
- ❑ Auxiliary power supply APS 24 (version PF 04A and older).
- ❑ Capacitor module CM 60 (version 00A and later) or CM 1.60 (version [CAP 00A] [VAR 02A] and later) replacing the previous one.
- ❑ Mains filters Power-Pro **are not compatible** with power supplies PS-❑❑A, PS-25B❑, XPS and RPS.

### 13.3 Module replacement

Replacing 380 V AC module with a new 460 V AC module involves:

- Drive MSC 12A or later.
- Auxiliary power supply APS 24 PF 05A and later.
- Capacitor module CM 1.60 (version [CAP 00A] [VAR 02A] and later).

**NOTE.** It may be incorporated into any servo drive system regardless of its power supply.

- Power supply PS-□□A.

**NOTE.** A PS-□□ power supply is required if the system includes an element that must work at a mains voltage of 380 V AC like an “MSC 11A” drive or an APS 24 “PF 04A” power supply or a capacitor module CM 60 “00A”. A PS-□□ is a PS-□□A. A factory limited to work at 380 V AC. It will admit a mains voltage limited to 380 V AC.

**NOTE.** If the system includes only “MSC 12A” drives, there is no compatibility problem. It will admit a mains voltage between 380 and 460 V AC.

- Power supply PS-25B□.

**NOTE.** A PS-25B3 power supply is required to work at 380 V AC if the system includes an element that must work at a mains voltage of 380 V AC like an “MSC 11A” drive or a capacitor module CM 60 “00A”.

- Compact drives.

**NOTE.** The compact drives (version MSC 05A and later) are designed to also run at 380-460 V AC; a PS-25B4 power supply must be installed; they have no compatibility problems with previous equipment.

### 13.4 VECON board

The compatibility between this board and the software versions is:

Version of the VECON board	Software version
VEC 03A and older	03.07 to 03.23
VEC 04A and later	03.24 and later 04.08 and later

**NOTE.** It is not possible to regulate with direct feedback when using a drive with software versions 04.xx and 05.xx and an asynchronous motor FM7. It is possible with versions 06.xx and later.

### 13.5 VECON-2 board

This board replaces the VECON board expanding the capacity of the flash memory and increasing the operating speed of the flash memory and of the RAM memory.

Version of the VECON-2 board	Software version
VEC 01A and later	05.08 and later 06.01 and later

**NOTE.** Software versions 04.xx and 05.xx of the drive have the same features. Their only difference consists in that they are supported by different hardware platforms because they have only VECON and VECON-2 boards respectively.

**NOTE.** It is possible but not recommended to have the same machine with several units where one controls its motor with a 04.xx version and hardware with VECON another one that controls its motor with a 05.xx version and hardware with VECON-2 and a third one that control its motor with 06.xx version and hardware with VECON-2.

# 13.

**COMPATIBILITY**  
Module replacement



DDS  
HARDWARE

Ref.1310

### 13.6 VECON-3 board

This board replaces the VECON-2 board.

Version of the VECON-3 board	Software version
VEC 01A and later	06.18 and later

**NOTE.** It is possible but not recommended to have the same machine with several units where one controls its motor with a 04.xx version and hardware with VECON another one that controls its motor with a 05.xx version and hardware with VECON-2 and a third one that controls its motor with 06.18 version or later and VECON-3 hardware.

### 13.7 VECON-4 board

This board replaces the VECON-3 board.

Version of the VECON-4 board	Software version
VEC 01A and later	06.26 and later 08.05 and later

**NOTE.** It is possible but not recommended to have the same machine with several units where one controls its motor with a 05.xx version and hardware with VECON-2 another one that controls its motor with a 06.18 version and hardware VECON-3 and a third one that controls its motor with 08.05 version and hardware VECON-4 hardware.

### 13.8 Boot for VECON-2

The boot of version v.06.02 and later of the WinDDSSetup allow loading the software versions on VECON-2 boards (version VEC2 02A).

**NOTE.** The boot of previous WinDDSSetup versions is incompatible with board versions VEC2 02A.

### 13.9 Boot for VECON-3

The boot of version 06.18 and older of the WinDDSSetup allow loading the software versions on VECON-3 boards (version VEC3 01A).

**NOTE.** The boot of previous WinDDSSetup versions is incompatible with board versions VEC3 01A.

### 13.10 Boot for VECON-4

The boot of versions 06.26 and 08.05 and older of the WinDDSSetup allow loading the software versions on VECON-4 boards (versión VEC4 01A).

**NOTE.** The boot of previous WinDDSSetup versions is incompatible with board versions VEC4 01A.

### 13.11 SERCOS card (16 MBd)

This card will not be compatible with software versions older than 06.05.

With software versions 06.05 and later, this new board may be used to exchange data between the CNC and the drives that make up the SERCOS ring at 2, 4, 8 and 16 MBd.

**NOTE.** Therefore, in order to select a baudrate higher than 4 Mbaud, the drive must have this SERCOS board and software version v.06.05 or newer.



**INFORMATION.** Drives having this board or older ones may be added to the SERCOS ring. However, all the drives must set with the same transmission speed.

13.

COMPATIBILITY  
VECON-3 board



DDS  
HARDWARE

Ref.1310

### 13.12 CAN board

Although this board was already recognized on FAGOR drives since software version 07.0x, now when using a FAGOR drive **that has a CAN communication board, always install software version 08.0x.**



**INFORMATION.** Remember that all the modules (CNC included) must be set with the same transmission speed.

**NOTE.** A SERCOS board and a CAN board cannot be installed in the same drive module at the same time; i.e. the communications interface must be either SERCOS or CAN, but not both at the same time.

**NOTE.** Drive modules with software versions 07.0x and 08.0x may be installed indistinctively in the same CAN field bus.

### 13.13 CAPMOTOR-x boards

Software	Interface	Motor feedback board
Up to 06.17	SERCOS	CAPMOTOR-1
06.18 and later	SERCOS	CAPMOTOR-1, CAPMOTOR-2
07.0x	CAN	CAPMOTOR-1, CAPMOTOR-2
08.01 to 08.04	CAN	CAPMOTOR-1, CAPMOTOR-2
08.05 and later	SERCOS/CAN	CAPMOTOR-2



**INFORMATION.** Remember that the CAPMOTOR-1 board has been discontinued.

Note that a CAPMOTOR-2, as opposed to CAPMOTOR-1, can process the signals coming from a serial motor feedback with SSI protocol or ENDAT (with incremental A and B signals, necessarily). However, it cannot process signals coming from resolver feedback, which can be processed by CAPMOTOR-1.



**MANDATORY.** Never install a CAPMOTOR-2 motor feedback board with a resolver as motor feedback. This combination is incompatible.

See chapter 12 that describes how to know whether the drive has a CAPMOTOR-1 or a CAPMOTOR-2 motor feedback board.

### 13.14 VECON-X boards

Software	Interface	VECON-X board
Up to 06.01	SERCOS	VECON
06.01 up to 06.17	SERCOS	VECON-2, VECON-3
06.18 up to 06.25	SERCOS	VECON-2, VECON-3
06.26 and later	SERCOS	VECON-2, VECON-3, VECON-4
07.0x	CAN	VECON-2, VECON-3
08.01 to 08.04	CAN	VECON-2, VECON-3
08.05 and later	SERCOS/CAN	VECON-2, VECON-3, VECON-4



**INFORMATION.** Remember that the VECON-2 board has been discontinued.

13.

COMPATIBILITY  
CAN board



DDS  
HARDWARE

Ref.1310

### 13.15 CAPMOTOR-2 board and type of feedback

Feedback device type	Motor feedback board
Resolver	CAPMOTOR-1
Stegmann™ encóder	CAPMOTOR-1, CAPMOTOR-2
Encoder with square signals U, V and W	CAPMOTOR-1, CAPMOTOR-2
Encoder with C and D signals	CAPMOTOR-1, CAPMOTOR-2
EnDat with incremental A and B signals	CAPMOTOR-2
SSI	CAPMOTOR-2



**INFORMATION.** Remember that the CAPMOTOR-1 board has been discontinued.

### 13.16 Recognizing RPS power supplies

From drive software version 06.09 on, it recognizes the identifier of RPS regenerative regulated power supplies and their parameters may be set.

**NOTE.** WinDDSetup versions older than 06.09 are incompatible with RPS power supplies.

### 13.17 APS-24 auxiliary power supply with PS, XPS or RPS

APS-24	XPS or RPS power supplies
Ref. PF 23A or older	Incompatible
Newer than Ref. PF 23A	Compatible

APS-24	PS power supplies
All PF references	Compatible

### 13.18 Power supplies compatible with FM9 motors

Motor references	PS power supply	XPS power supply	RPS power supply
FM9-B055-C5C□-E01-A	Incompatible	Incompatible	RPS-75
FM9-B071-C5C□-E01	Incompatible	Incompatible	RPS-80

13.

COMPATIBILITY

CAPMOTOR-2 board and type of feedback



DDS  
HARDWARE

Ref.1310







FAGOR AUTOMATION

**Fagor Automation S. Coop.**

Bº San Andrés, 19 - Apdo. 144  
E-20500 Arrasate-Mondragón, Spain

Tel: +34 943 719 200  
+34 943 039 800

Fax: +34 943 791 712

E-mail: [info@fagorautomation.es](mailto:info@fagorautomation.es)  
[www.fagorautomation.com](http://www.fagorautomation.com)

